

# YASKAWA

## Machine Controller MP3300



e-motional  
solution



# MP3300

Certified for  
ISO9001 and  
ISO14001



JQA-0422 JQA-EM0202

## Optimal motion control

# MP3300 turns your problems into opportunity.

The years since the original launch on the market of the MP machine controller series back in 1997 have been witness to an impressive evolution as the series has successfully responded to a variety of needs. These needs have included improvements in the high-speed performance of machines and systems and enhancement of productivity by reducing takt times, cost reductions as a result of streamlining systems, and advances in making the operation of the systems more visually identifiable.

The year 2013 marks the birth of the MP3300 with its 7 ultimate e-motional solutions. This is a machine controller series that offers solutions from many different aspects—examples include machine and system performance, operating ease, the environment, safety and maintenance—that are sure to inspire you and improved your operations. As the successor to the MP2000 series, the new series continues to be the same size while delivering the industry's fastest scan synchronization. In addition to the  $\Sigma$ -7 series of AC servo drives, there is a strong lineup of the products available from Yaskawa's partners so that you can achieve the best possible motion control.



# MP3300



## 1 System performance

Incorporation of the fastest CPU translates into high-speed and high-accuracy control. It is easy to construct a high-speed, multi-axis system by way of connection with a unit that supports MECHATROLINK-III.

## 2 Easy to use

The adjustments of a multi-axis system can be completed in a short period of time using the MPE720 Ver.7 system integrated engineering tool. It is also easy to add a motion system to an existing sequence system.

## 3 Environmental performance

The specifications of the environments in which the machine controller can be used have been expanded to increase the range of its application. Furthermore, it is possible to monitor the power level of motion systems so a viable contribution is made to the conservation of energy.

## 4 Safety and security

Temperature sensors are installed in the MP3300 to insure protection from temperature problems. In addition, by monitoring the temperature condition of the motion system, temperature problems in the system can be pinpointed at an early stage to ensure safety and security. Security measures have also been stepped up to prevent the outflow of know-how that is a problem when products are exported overseas.

## 5 Support

The support available from Yaskawa now makes it now easier to handle large-capacity data on the system operation statuses and so on, thereby improving traceability on the production floor. Also now available as new support services are the cloud service and services that make full use of QR codes and smartphones: In this way, it has become more and more convenient for users to store and control product information.

## 6 Lineup

In addition to the  $\Sigma$ -7 series of AC servo drives, there is a strong lineup of the products available from Yaskawa's partners.

## 7 Compatibility

Compatibility ensures the continued use of the optional modules and program applications of the MP2000 series just as they are. Replacing the MP2000 series with the MP3300 can be completed totally hassle-free.

### C O N T E N T S

Features	4 ■
Related Products	15 ■
System Configuration	22 ■
Hardware Specifications	24 ■
· Installation and Operating Conditions	24
· MP3300	25
· Optional Modules	26
· Other Manufacturer Modules	41
· Other Devices	43
· Dimensions	44
Software Specifications	46 ■
Sequence Controls/ Motion Controls	46
Support Tool	47 ■
MPE720 Ver.7	47
Ordering Reference	52 ■
Order List	52
International Standards	56 ■
Read Before Ordering	59 ■

## Enhanced control performance

The MP3300 delivers high-speed and high-level performances, and expands program capacity. The MP3300 is also capable of high-speed, synchronized communication with MECHATROLINK-III compatible Servo Drives and AC Drives.

### Improved CPU performance\*

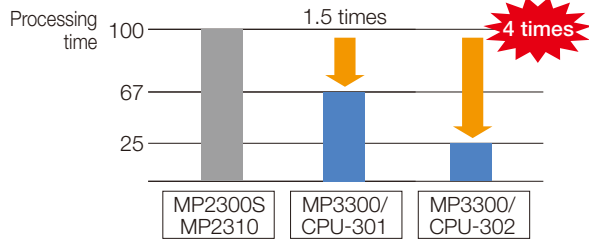

\*: Ladder operation speed where the scan time of the MP2300S/MP2310=100

### Expanded program capacity

Application program capacity

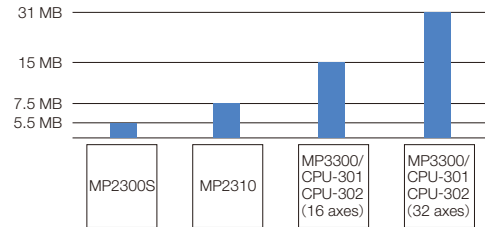

Number of drawings

Number of drawings	MP2000 series	MP3300/CPU-301/302
For high-speed scan	200 drawings	1000 drawings
For low-speed scan	500 drawings	2000 drawings
For user function	500 drawings	2000 drawings

## Double-precision real-number, 64-bit integer data for higher precision

Dicer

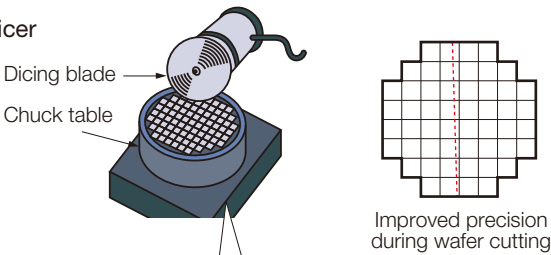

With double-precision real-number 64-bit integer data, rounding errors during arithmetic calculations are reduced, and control at higher levels of precision can be achieved.

Dispenser



Controlling the path performance in the corner areas is an issue: however, implementing path control with a higher level of precision enhances dispensing quality.

## Fastest motion network in the industry

### Fastest transmission cycle: 125 μs (4 stations)

The MECHATROLINK-III motion network, which is among the fastest in the industry, is provided with the main unit CPU of the MP3200 as a standard option. The smoother motion control results in higher levels of precision.

MECHATROLINK-III		
Transmission Speed	Transmission Cycles (Number of Connected Stations)	
100Mbps	125 μs (4 stations)	500 μs (14 stations)
	250 μs (8 stations)	1.0ms (16 stations)*

\*: The maximum number of stations, including I/O, is 21.

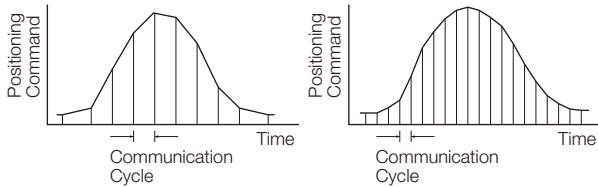

## Control of 32 axes; systems expansion at no additional cost

The MP3300 can control large-scale systems with 32 servo-drive axes for a maximum of 42 stations per circuit. If a system is to be expanded, this makes it possible to minimize the additional cost of the options and construct a flexible system.

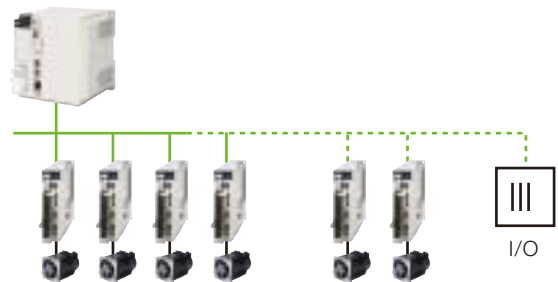

CPU-301/302 (16 axes) : 21 stations max. (Number of servo axes are 16 axes max.)  
 CPU-301/302 (32 axes) : 42 stations max. (Number of servo axes are 32 axes max.)

## All-in-one four control modes

Every aspect of control from simple to complex operations can be achieved using one CPU without adding optional modules for each kind of control.

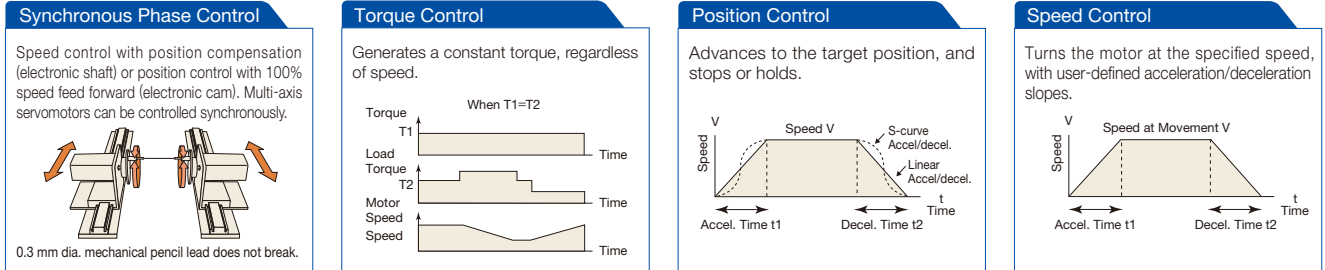

## Switch between any of the modes while on-line

In addition to the position, speed and torque modes of control that are required for controlling a system, the MP3200 also features the synchronous phase control mode for which a high control performance is required, and switching between these four modes can be readily accomplished while on-line.

### ● Packaging machines

Synchronized phase control enables cutting, sealing and other kinds of processing that are synchronized with the movement of the workpiece.

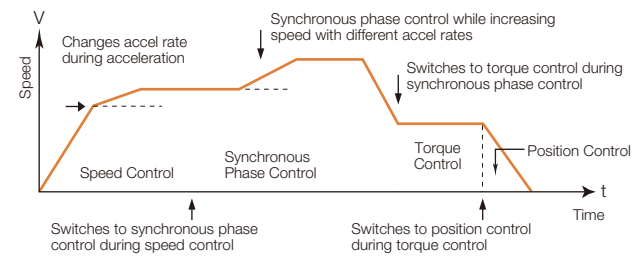
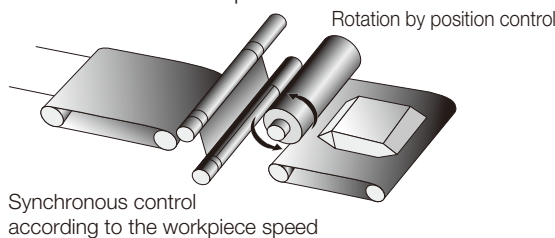

### ● Injection molding machines

Switching from position control to torque control can be executed without deceleration.

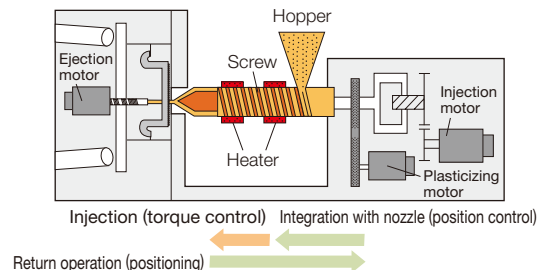

## The MP3300 Brings a Cornucopia of Solutions

### ■ Gantry Mechanism and Alignment Stage Mechanism

These mechanisms comprise the basic system used in devices for the manufacturing and the inspection of semi-conductor chips, LCDs, and other components. High precision as well as high acceleration and deceleration are required for these processes. Two axes must be synchronized to control and operate the gantry mechanism.

**Advantage** Achieves complete synchronous multi-axis control and online adjustment.

### ■ Solution for Conveyance

Provides a solution for the control mechanism that allows workpieces to be processed in accordance with the speed of the production line.

**Advantage** Allows the slave axes to follow master axis operation when the inverter is used as the master axis and both the inverter and servo drives are connected through a network.

### ■ Solution for Winder

Provides a solution for the control mechanism where a winder winds and a feeder unwinds.

**Advantage** Achieves high-precision winding, feeding, dancer control, and tension control with standard servo drives and inverters. Line control can be constructed easily with user functions set in advance.



## Automatic setup using the self-configuration function

The self-configuration function automatically recognizes the configuration of the optional modules and servo units connected to MECHATROLINK, as well as the I/O devices, and sets the required definitions.

### ● When the Dip Switch is to be used

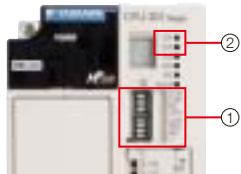

- ① Set the INIT and CNFG to ON, and then turn ON the power supply.
- ② RDY and RUN lit.
- ③ Set INIT and CNFG to OFF after setup has been completed.

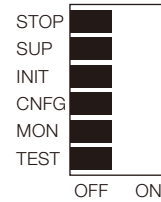

### ● When the MPE720 is to be used

#### • When the MPE720 Version 7 Engineering Tool is to be used:

- ① Click the Module Configuration Button on the My Tool Tab Page.
  - ② Click Self Configuration-All modules.
- Click the OK Button on the dialog box. Self configuration for all modules is executed.

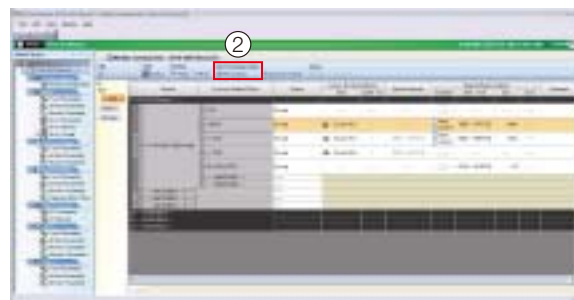
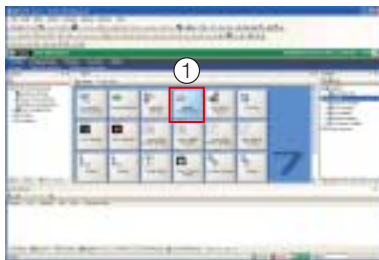

## Reduced servo adjustment time for multiple axes

Instead of opening an adjustment screen for each axis, multi-axis tuning can be performed on one screen, which dramatically reduces the setup time.

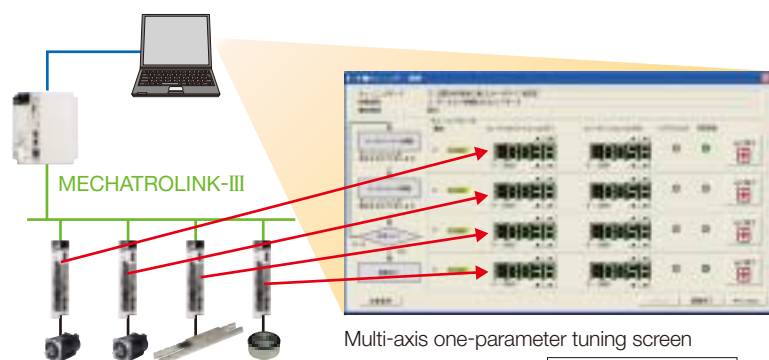

Multi-axis one-parameter tuning screen  
(Using MPE720 Ver.7) Under development

## Save time and reduce costs with Yaskawa's ideal motion control system

Simplify the construction of standardized drive systems that work with any PLC using Yaskawa's ideal motion control system for servo drives.

### ● Easily add motion control to an existing PLC

#### Positioning Systems that Use PLC

Problem

When similar systems but different types of PLCs are used, motion control programs will be different for each PLC, as shown below.

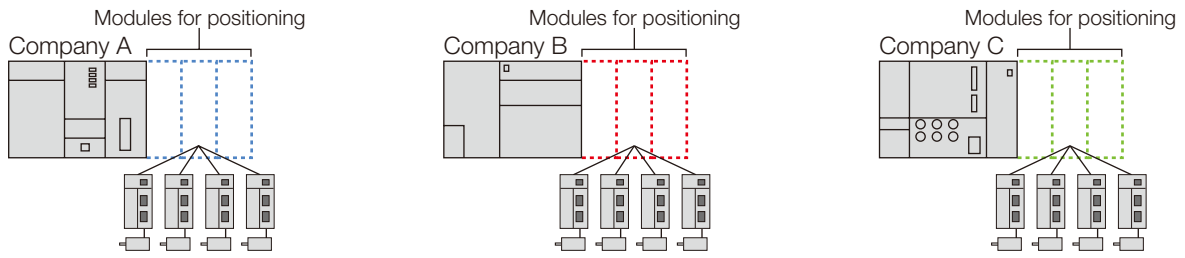

#### Positioning System with MP3300

Solution

The same motion control programs can be used by adopting the MP3000 Series, which can be connected to the PLC of each company.

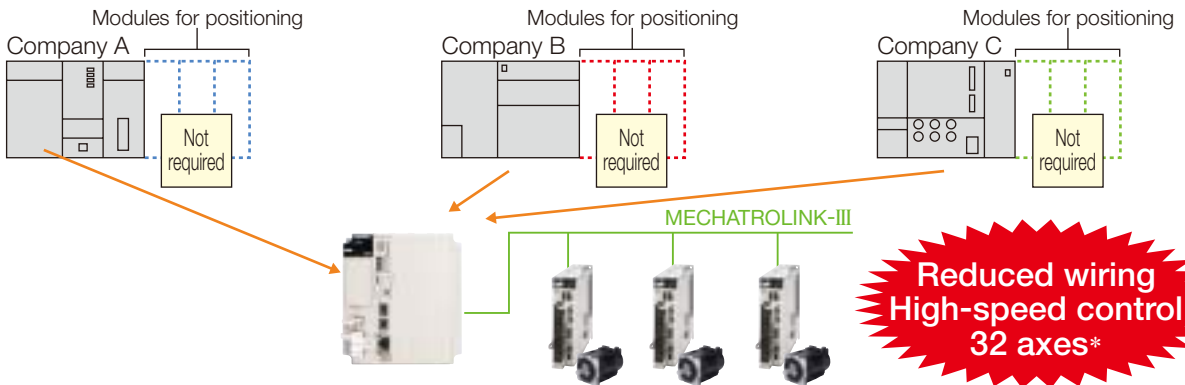

### ● PLC connection with a simple setup and no complicated programming

#### Procedure

- ① Select a PLC product.
- ② Enter the IP address of the PLC.
- ③ Enter the port number of the PLC.
- ④ Establish the connection by clicking the OK Button.

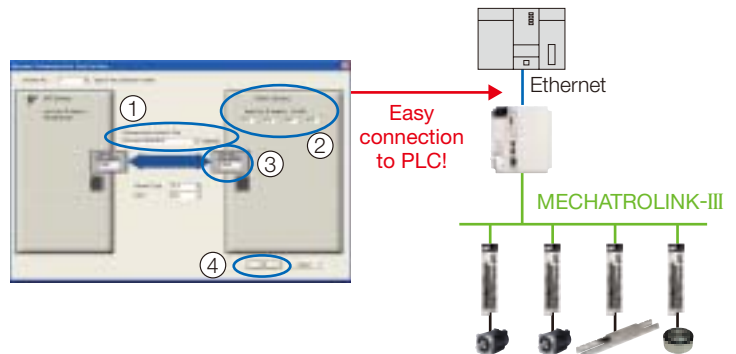

## A tough performer in harsh environments

- Expanded surrounding air temperature range: 0°C to 60°C (a cooling fan is required inside the board if the temperature is going to rise above 55°C).
- Satisfies the latest versions of the JIS B 3502 standard.
  - Expanded surrounding air humidity range: 10% to 95% relative humidity
  - Improved degree of pollution: Pollution Degree 2
  - Improved resistance to vibration (expanded vibration amplitude).
- Same environmental resistance features as the MP2000 series.
  - Installation even in areas at an altitude of 2,000 meters possible.
  - Varnishing supported for standard product.
  - Available for products with enhanced resistance to vibration (optional).
  - Noise resistance performance that is at least comparable to that of the MP2000 series assured.



## Supports energy conservation with visual motion system

A power monitor for the motion system connected to the MP3300 is provided. This feature supports the monitoring of the power on a day-by-day basis and annual plans for reducing the level of power used.

Monitoring of the amount of energy used enabled

日次消費電量	消費電量	消費電量	消費電量
1月1日	0.000 kWh	0.000 kWh	0.000 kWh
1月2日	0.000 kWh	0.000 kWh	0.000 kWh
1月3日	0.000 kWh	0.000 kWh	0.000 kWh
1月4日	0.000 kWh	0.000 kWh	0.000 kWh
1月5日	0.000 kWh	0.000 kWh	0.000 kWh

Monitoring display (image)

## Reduces environmental impact

REACH Regulation is supported.

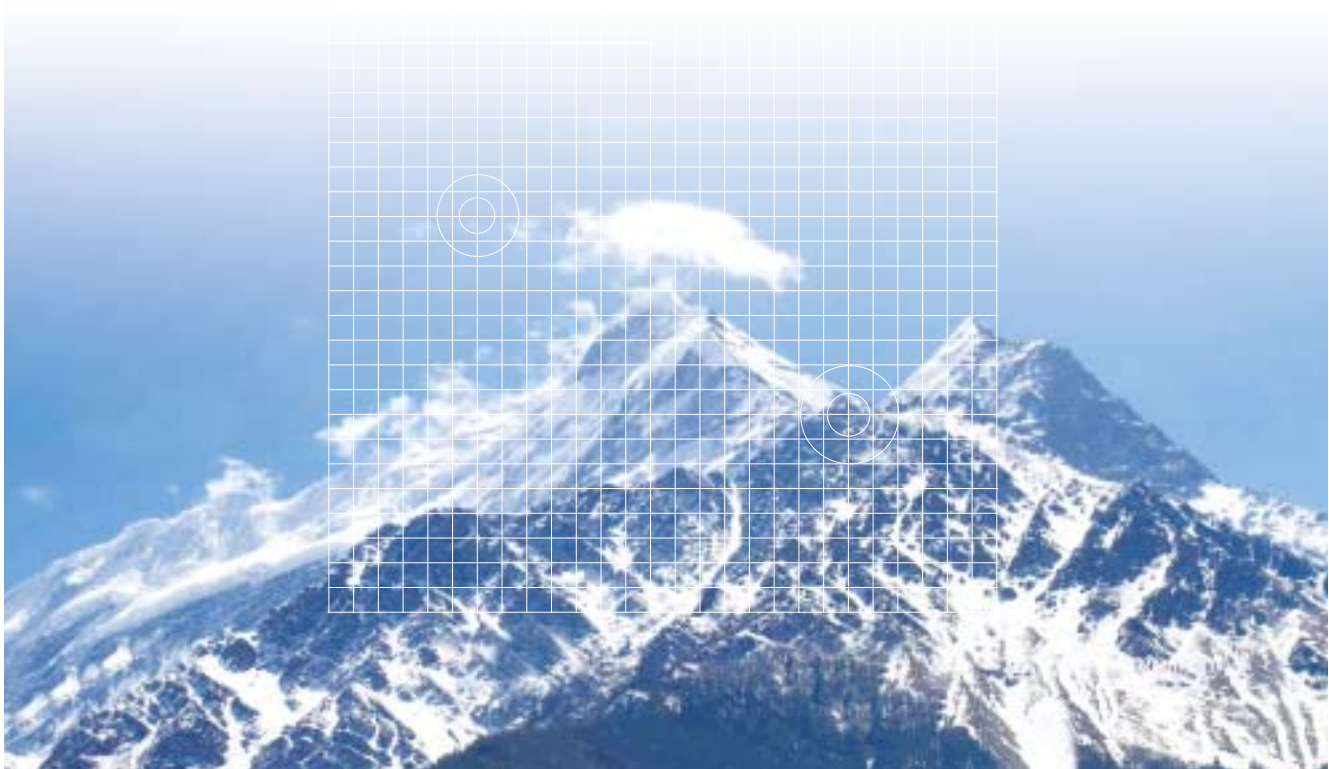



## Protect systems from high temperatures

MP3300,  $\Sigma$ -7 SERVOPACKs, and servomotors are equipped with temperature sensors that can directly monitor temperatures of machines and detect abnormalities to prevent failures. Real-time temperatures can be viewed on a display by using MP3300.

### Protection from abnormal temperatures



## Tight security to prevent unauthorized access to trade secrets

### Several kinds of powerful functions to prevent unauthorized access

Security functions stand guard to block off multiple possible entry points including programs, projects, controllers, and users.

Possible entry point	Unauthorized access prevention function	Description	Effect
Users	User management	Management and limit of a user attempting to access the controller	Unauthorized access from the unauthorized user is prevented.
Controller	On-line security	The password setting for accessing the controller	Unauthorized access to the controller is prevented.
Project files	Project password	The password setting for accessing the project files	Unauthorized access to the project files is prevented.
Programs	Program password	The password setting for accessing the programs	Unauthorized access to the programs is prevented.

### All security functions managed together on a file-by-file basis

Levels of privilege for reading data from and writing data in the files can be established to control access to the files.

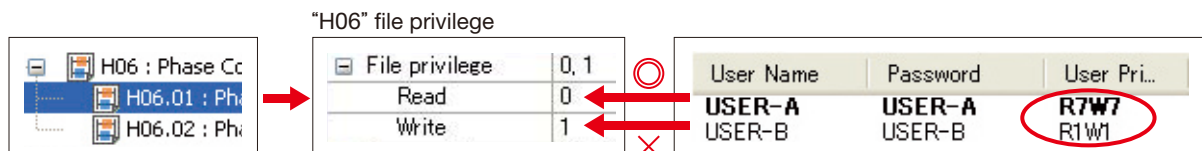

To open the H06 file, the user must have read privilege level 5 or above. To edit and save the H06 file, the user must have write privilege level 6 or above.

### Control of access using passwords

Passwords can be set for entire project files or for individual programs.

By setting the password ahead of time → Access can be confined to only those individuals who know the password.

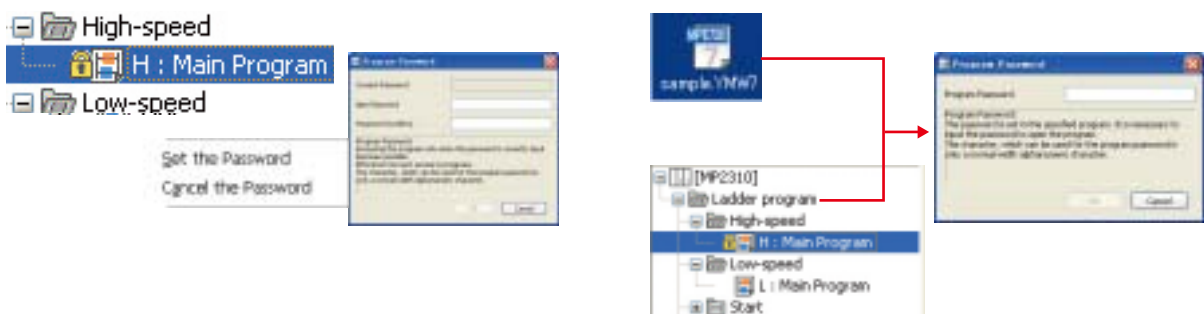

## Enhanced Usability and Traceability

Large volumes of data handled with ease.  
Effective use of function for data logging and file transfers.

USB memory device

Model	Spec.	Manufacturer
SFU24096DBP1TO-C-QT-111-CAP	4GB USB memory	Swissbit Japan Inc.

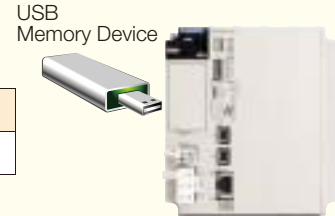

### Easy loading and saving of project files on-site

USB memory device

Operations can be performed using the DIP switches on the CPU unit body. Even in places where a PC cannot be brought in, you can update the versions of the equipment and back up the data on-site with ease.

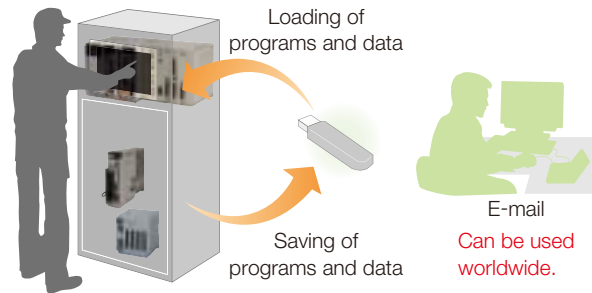

### Reading and writing large volumes of register data

USB memory device

Import and export register data with new ladder program instructions. Even large volumes of data can be handled with ease.

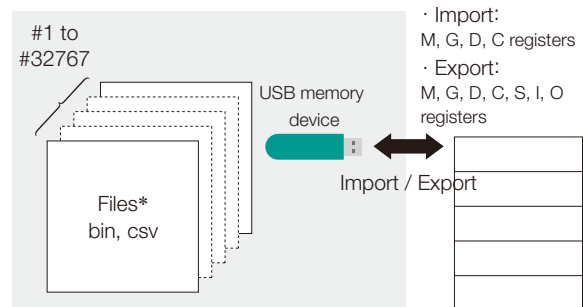

### Save system's operation statuses onto internal RAM or USB memory device

Logging function

The logging function allows the system's operation statuses (logging data) to be saved in the USB memory device connected to the CPU or in the RAM inside the CPU unit. Either the binary or CSV format can be selected for the data to be saved.

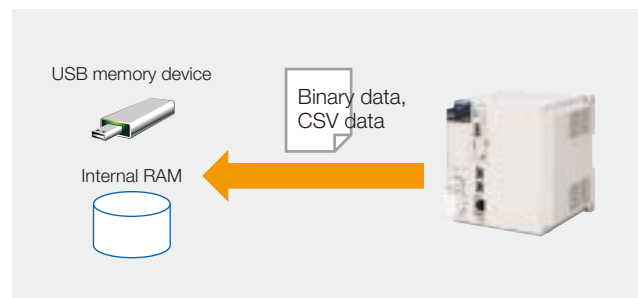

## Recognize and note every single data change

Logging function

Data logging is possible at the timing that is synchronized with the scanning, so even the smallest data changes not normally recognized can now be caught.

High-speed logging in sync with the scanning allows the kind of trouble that was missed before to be discovered and the causes of the trouble to be cleared up with a high degree of accuracy.

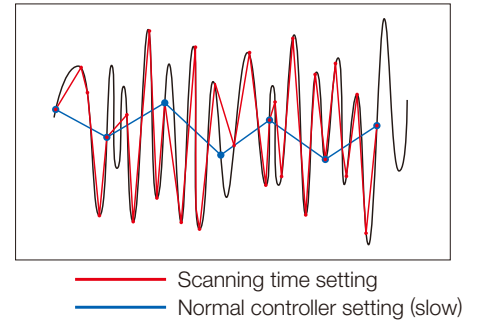

## Setting of conditions also possible

Logging function

Settings can be selected for the conditions under which the logs are output. The logging data is saved only if the values of the specified registers fail to meet the output conditions. This enables a rapid response when trouble occurs.

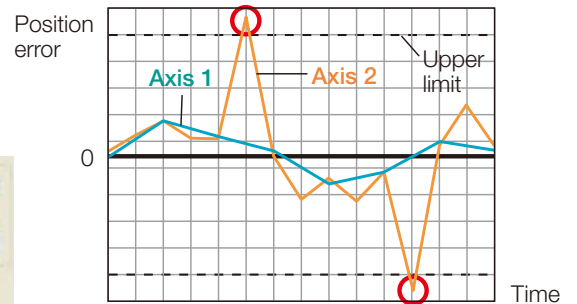

## Easy access from remote host systems

File transfer function

By using the file transfer function (FTP server function), the logging data or register data in the CPU unit's internal RAM or the USB memory device can be downloaded from a remote location to a host system\*.

\*: System provided with an FTP client function

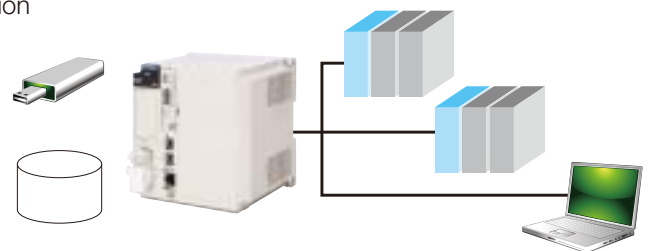

## Improved traceability with large accumulation of data

File transfer function

By transferring the system's operation data (logging data and register data) at the specified synchronization, large volumes of operation data can be acquired with no fear that the data may be unexpectedly damaged. As a result, the traceability at the production site is vastly improved.

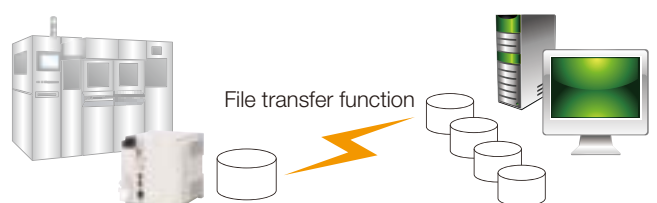

## MechatroCloud, Yaskawa Electric's New and Innovative Service

# MechatroCloud

MechatroCloud is a cloud service offered by the Motion Control Division of Yaskawa Electric. With this service, it is now easier and more convenient to use Yaskawa's motion control products. A wide range of services are now available through Yaskawa's website, smartphone applications, and QR codes.

- Notes: 1. MechatroCloud is available in Japan only.  
 2. "QR code" is a registered trademark of DENSO WAVE, Inc.

### Easy troubleshooting with **SigmaTouch!** Anytime, Anywhere

"SigmaTouch!" is a smartphone application for MechatroCloud. Product information, such as manufacturing information and parameter lists, can be viewed by simply using a smartphone camera to read the QR codes of Yaskawa Electric's products. Alarm details and troubleshooting information can also be viewed on the smartphone, which can greatly reduce recovery time.

- Note: The QR codes can be read with Android OS 4.0.3 or later versions.  
 The Android must be connected to the network to use this service.



Use **SigmaTouch!** for **free!**

### Innovative service that links users to cloud data!

With the use of SigmaTouch!, users can quickly and easily access the MechatroCloud server, which contains the latest product information from Yaskawa Electric's plants and maintenance information from the e-mechatronics website in a timely manner.

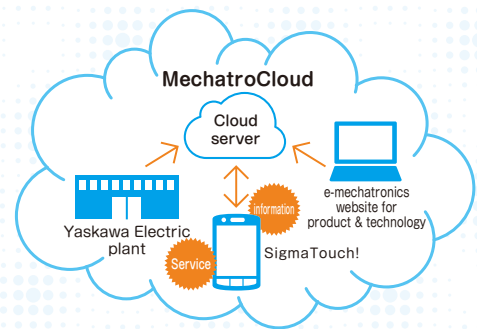

### Easily search for product information using SigmaTouch!

Users can search for troubleshooting information for a specific model and view product manuals on a smartphone by using a smartphone camera to simply read the QR code of the product.

Members of the e-mechatronics website have immediate access to all functions. (Non-members can access some functions.)

- ◎ : Can use all functions and view information of BTO products.
- : Can use all functions.
- △ : Can view some information.

	Corporate members	Individual members	Non-members
Product information	◎	●	△ Nameplate info only
Manuals	●	●	
Troubleshooting	●	●	

Read QR code with a smartphone



You can construct a system that exactly meets your requirements using communications networks and the rich lineup of products offered by Yaskawa's partner companies.

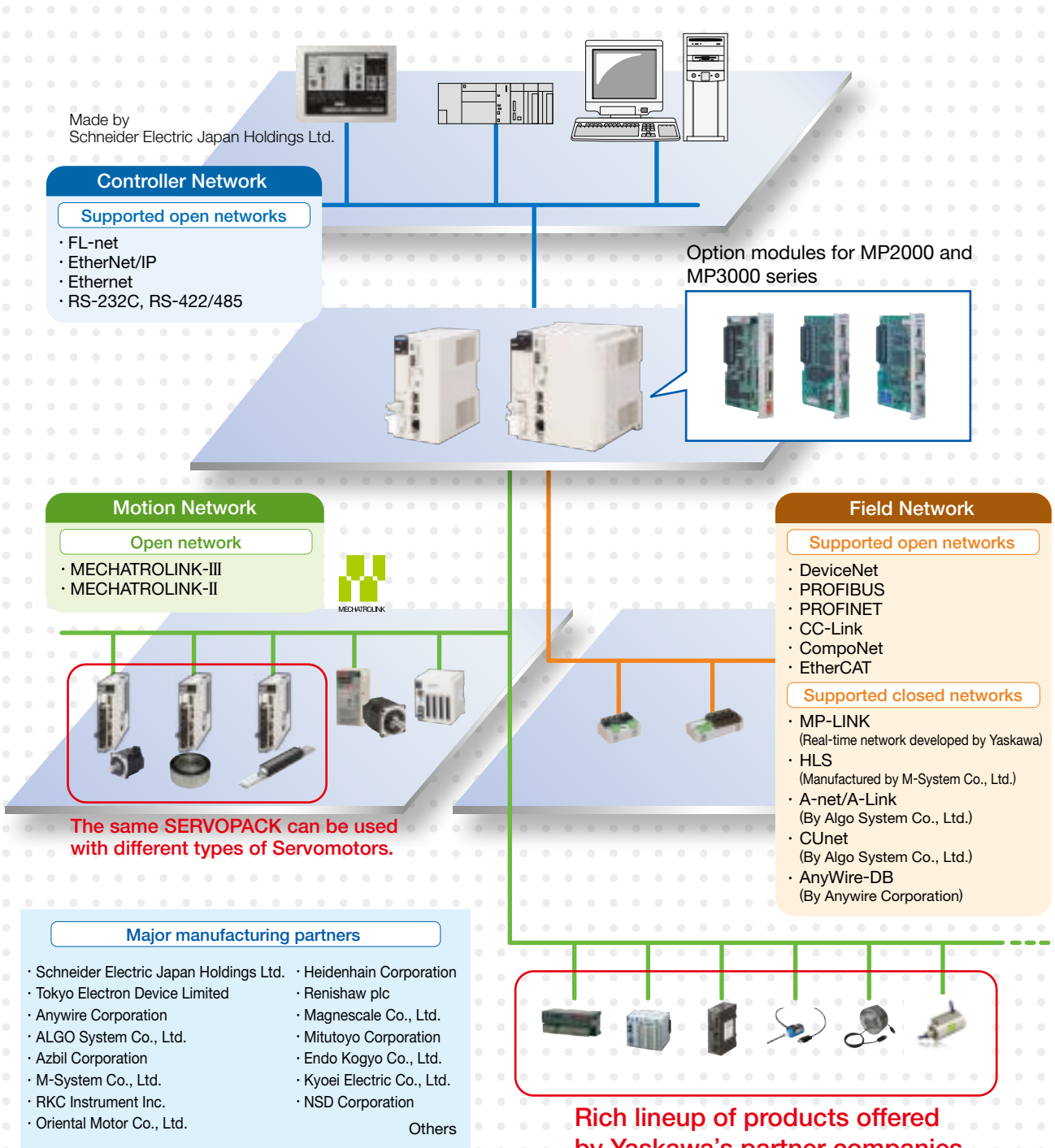

## Centralized control over the entire system

The MPE720 Ver. 7 engineering tool integrates the engineering environments for servo, inverter, and I/O devices into a single software package. This enables all-in-one engineering from setup to maintenance of drive units connected to an MP3000 series machine controller via the MECHATROLINK network.



[Reference] See MPE720 Ver.7 catalog (No. KAEP88076100) for details.

## Execution of parameter settings and monitoring enabled for multiple axes simultaneously

The parameter settings and monitor windows of the drive units can be executed for a multiple number of axes simultaneously.

Establishing the settings for the entire system is a simple job, and comparing the monitors on an axis-by-axis basis is also easy.

## Efficiency improved by choosing the programming method that works best for the user

### Ladder programming

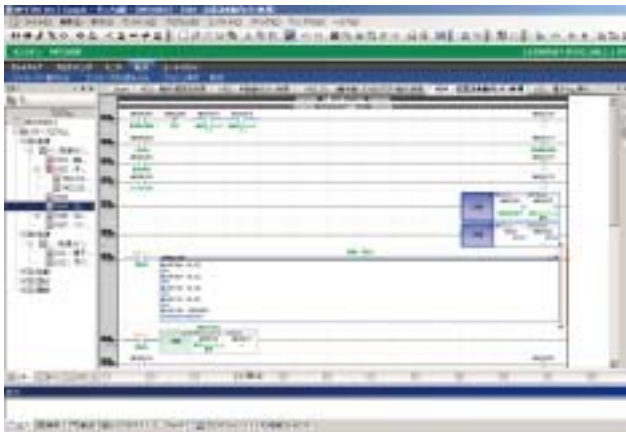

- A new user interface (UI) enables operations to be undertaken easily by anybody.
- All types of control including position, speed, torque, and phase control are supported.
- Arithmetic expressions in the ladders have been made even simpler by boosting the EXPRESSION instructions.

### This system is recommended for:

- Users who are using a PLC

### Motion programming

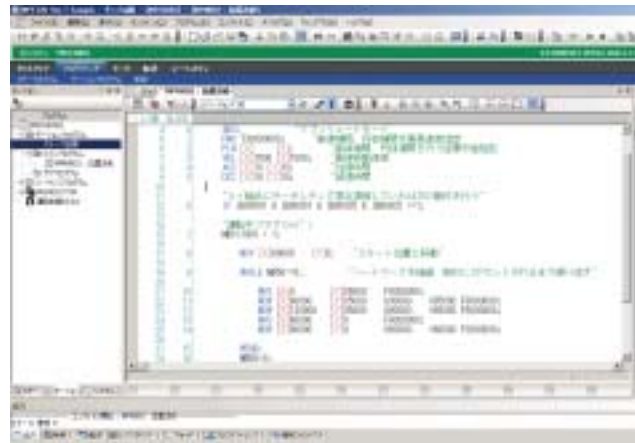

- Positioning and interpolation instructions can be described using single instructions.
- Programs can be very easily edited using expressions in a text format.
- New variable programming can provide PC-like programming.

### This system is recommended for:

- Users of PC based devices and in-house fabricated boards (C language, BASIC language)

Made by Yaskawa Electric Corporation

## MYVIS YV260 Network Machine Vision System

In this example, the MYVIS YV260 is connected to the open motion network MECHATROLINK. With MECHATROLINK communications, the MYVIS can receive data on the current position of the motor's axes in succession. Using this data, the necessary adjustments are determined for high-accuracy calibration of the machine coordinate system.

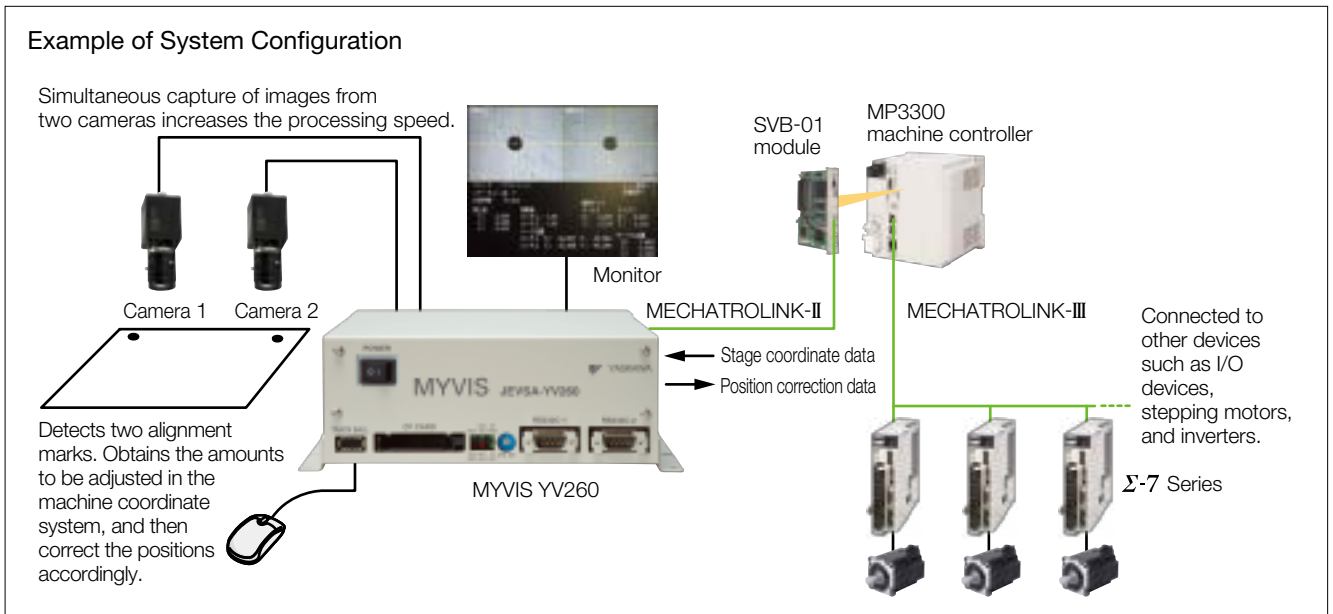

Item	For Analog Cameras	For Camera Link
Model	JEVSA-YV260□1-E	JEVSA-YV260□2-E
Image Processing	Gray scale pattern matching, binary image analysis etc.	
Memory	Application Program	512 Kbytes (flash memory)
	Backup Memory	256 Kbytes CMOS (for saving parameters)
	Template Storage Memory	CF cards (2 Gbytes max.)
	Image Frame Memory Memory Template Memory	4096 × 4096 × 8 bits × 4 images (Can be used for 640 × 480 × 8 bits × 192 images)
Image Input	Camera Interface	New EIAJ 12-pin connector × 4 VGA (640 × 480) to SGXA (1280 × 960) Four B&W, 8-bit A/D-converter circuits
	Camera Power Supply	Single camera: 12 V, 400 mA, Total: 1.2 A
	Camera Sync Mode	Internal/external sync
	Random Shutter Supported	Sync-nonreset, sync-reset, single VD or V reset
	Simultaneous Image Capture	Four cameras
Monitor	Input Image Conversion	Gray level conversion (LUT), mirror mode
	Monitor Output	VGA, XGA (color), 15-pin D-sub
	Image Display	A full-screen or a partial-screen for one camera, simultaneous screen reduction for two or four cameras, gray level conversion (binary image display supported)
I/F	Field Network	MECHATROLINK-I/II
	LAN (Ethernet)	10BASE-T/100BASE-TX
	General-purpose Serial	RS-232C × 2 channels (115.2 kbps)
	Parallel I/O	16 general-purpose outputs (4 of these are also used for stroboscope) +2 outputs exclusive for alarms (24 VDC, photocoupler isolation) 16 general-purpose inputs (4 of these are also used for trigger) +3 inputs exclusive for mode switchings +1 input exclusive for trigger (24 VDC, photocoupler isolation)
	Track Ball	USB mouse
Power Supply	100 V/200 VAC, 24 VDC, 30 W	

Main Partner Manufacturer

M2M Communication Adapter

Yaskawa Information Systems Corporation

The M2M communication adapter offers one-stop solution for remote control and monitoring as well as management of devices via mobile communications networks. The environment required for remote monitoring is offered as a set.

### MMLink-3G, Global Communication Adapter

This communications device for the Internet of things (IoT) delivers seamless remote monitoring and control via 2G and 3G networks.

Features

- 1 Supports connection to 2G and 3G networks.
- 2 Data transfer possible over wide areas
- 3 Equipped with GPS navigation system
- 4 Supports various communications protocols
- 5 Easy initial settings



### MMLink-GWL, Multi-carrier LTE-compatible Communications Adapter

LTE gateway with multi-carrier support

Features

- 1 Supports multi-carrier LTE (Docomo and au networks).
- 2 Equipped with IPSec, PPTP, L2TP, GRE, and OpenVPN as standard
- 3 A compact size that can be easily incorporated into equipment (93×90×27 (mm)).
- 4 Redundancy through dual SIM cards (failover)
- 5 Additional applications can be built and customized (development support is available).



### MMLink-Lite 3G, Industrial USB Communications Adapter

A carrier-independent SIM-free industrial USB communications adapter

Features

- 1 Select a domestic or international carrier or an MVNO according to the application.
- 2 A compact and lightweight device compatible with various installation environments.
- 3 Equipped with GPS positioning function
- 4 Easy to install with USB cable interface
- 5 Available in two models: Standard version and advanced version



M2M Cloud Service

### MMCloud, Cloud Service for Product Life Cycle Management Support

This is a cloud service that collects and manages the operational information of products and related information in order to support the management of the life cycle of products.

Features

- 1 **Supports management of product life cycle**  
Product information that is managed separately can be consolidated and used for work in various processes, including planning, development, sales, inspection, and maintenance.
- 2 **Enables ideal monitoring of equipment located in different locations around the world**  
Global-scale monitoring of equipment is made possible by using internet connections and wireless communication networks for mobile phones. User environment is also globalized. Local times of different countries where equipment are used can be displayed and languages can be selected on the screen.
- 3 **Displays collected information in real time**  
Collected data, status of customer equipment, information collected via sensors, and GPS information is displayed in graphs and maps so that equipment conditions can be checked in real time. This service can be used to monitor operation status and mobile equipment.
- 4 **Can start with a small-scale operation**  
Customers can first use this service with a small investment and a short leadtime by using the standard cloud service. The monitoring scale can be increased in line with the expansion of the customer's business operations.



### MMPredict, Failure Prediction Service

MMPredict is a service that uses artificial intelligence techniques to predict failures of equipment using accumulated sensor data.

Features

- 1 Failures can be predicted to a high degree of accuracy with our proprietary techniques.
- 2 Failure points can be estimated from information provided by sensors.

Website

<http://www.ysknet.co.jp/>





Programmable  
Display

Schneider Electric Japan Holdings Ltd.

### Pro-face GP4000 Series

The GP4000 series display features a touch screen that can be connected directly, without using any application programs, to control devices, such as controllers, servo drives, and AC drives. Current conditions of these devices is displayed on the screen so that they can be set up, adjusted, and maintained on site. Users can easily check operational status, edit registers, identify errors, and update or backup application programs without using a computer. The GP4000 series supports Proface Remote HMI, the remote monitoring software for mobile devices. This allows users to view product information on tablets and smartphones anytime, anywhere.

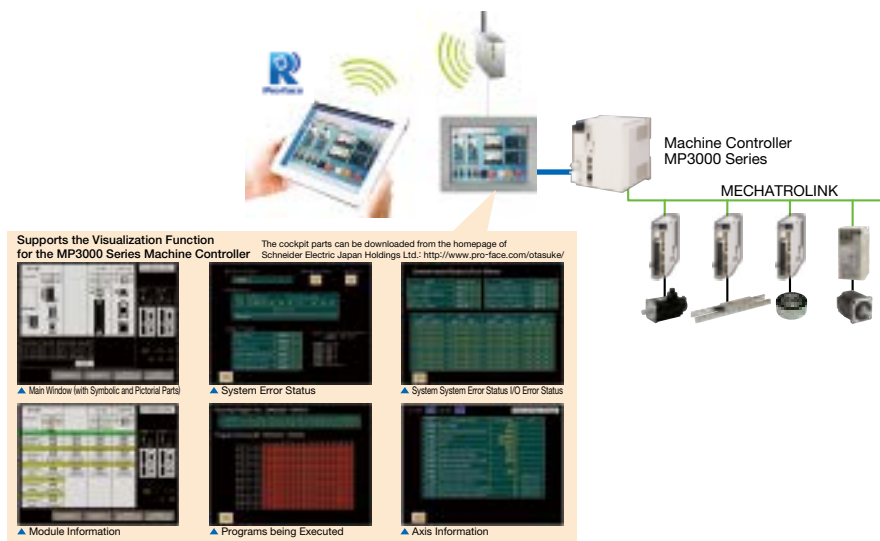

### Engineering Support Function

#### ● Program Transfer with an External Memory Unit!

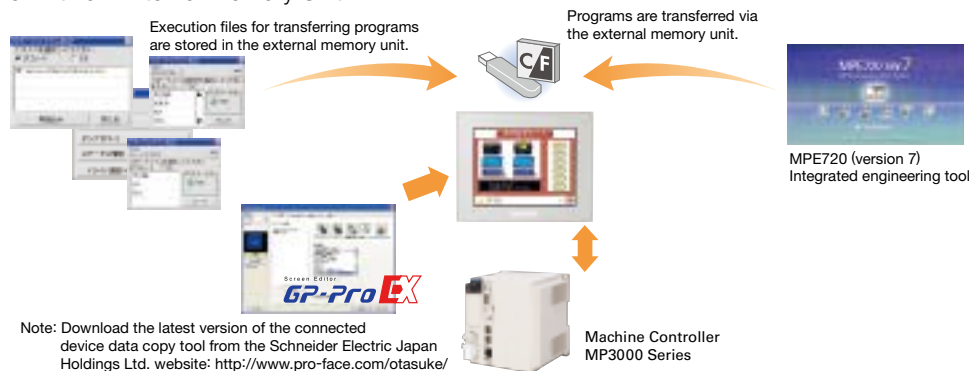

#### ● Adjustment and Maintenance of Servo Drives and Inverters Right on the Touch Panel!

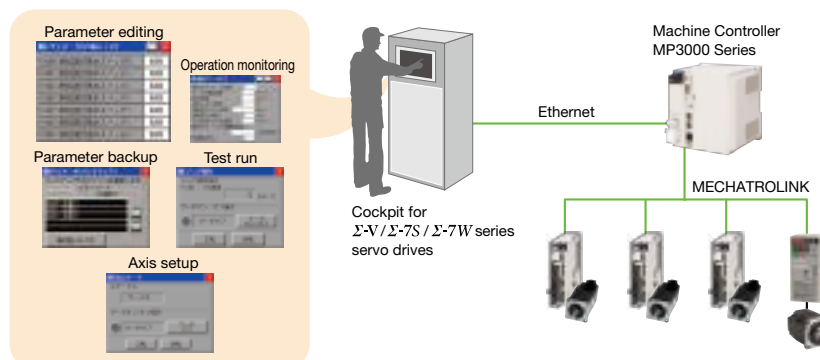

Website <http://www.proface.co.jp/product/hmi/gp4000.html>

## Main Partner Manufacturer

### IP Core

### Tokyo Electron Device Limited

#### MECHATROLINK-III Master/Slave IP Core

Model: Master: TIP-ML3MST-PROJ···Supports Xilinx, Inc. Spartan-6 LX/LXT FPGAs and Zynq-7000 SoCs.

Slave: TIP-ML3SLV-PROJ···Supports Xilinx, Inc. Spartan-6 LX/LXT FPGAs (single slave and multi-slave functions).

This original IP core for FPGAs manufactured by Xilinx, Inc. significantly reduces the number of components on a board. This reduces development costs and time required for development can be significantly reduced.

- Supports MECHATROLINK-III master and slave functions.
- Delivers a high-speed host interface synchronized with a 66 MHz clock (max.).
- Enables flexible system configuration by using FPGA fabrics.

Website <http://ppg.teldevice.co.jp>

### I/O Module

### M-System Co., Ltd.

#### MECHATROLINK-I- and -II-compliant Remote I/O

Model: R7ML series, R7K4FML, R7K4DML, R7G4HML

- Can handle 16 to 32 discrete I/O signals, 4 analog input, and 2 analog output signals.
- Analog and discrete signals can be mixed.
- 3M screw terminals (2-piece configuration) are used for power supply and I/O terminal blocks. Saves space because relay terminal is not required.
- R7K4DML-B used with e-CON connectors for I/O connection is also available.



R7ML Base Module

#### MECHATROLINK-III-compliant Remote I/O

Model: R7G4FML3, R7G4HML3, R7F4HML3, R7K4FML3, R7K4JML3

- Can handle 16 to 64 discrete I/O signals and 4 analog output signals (max.).
- Equipped with discrete I/O, DC input and output, temperature input, and rotary encoder input.
- High-speed A/D conversion unit (conversion speed: 200  $\mu$ s) and Strain Gauge Input Module are available.
- 3M screw terminals (2-piece configuration) are used for power supply and I/O terminal blocks. Saves space because relay terminal is not required.
- R7K4JML3-E used with spring clamp connectors for I/O connection and R7F4HML3-D used with MIL connectors are also available.



R7G4FML3-6

### Master Module

#### HLS (High-speed Link System) Master Module

Model: MPHLS-01

- Master module that can be used with MP2200, MP2300, and MP3300 series machine controllers.  
Note: When using this module with a MP3200 machine controller, attach a MP2000 base unit (optional) to the machine controller first and install this module in the base unit.
- Wiring for discrete I/Os and analog I/Os can be reduced with M-System's rich product lineup of remote I/O modules (R7HL and R7F4DH series) that can be connected to the HLS master module.



Website <http://www.m-system.co.jp/>

### A-net/A-Link Unit

### ALGO System Co., Ltd.

#### A-net/A-Link Master Unit Module

Model: MPANL00-0

This A-net/A-Link master unit module can be directly attached to the MP3200 Controller. The resulting system needs less wiring and conforms to SEMI E54.17.

- | Features |   |
|----------|---|
| 1        | Two H8S units by Renesas Technology Corp. can be added maximum.   |
| 2        | Max. 4032 points can be scanned in 0.95 ms (at 12 Mbps).<br>Note: The case using two A-Link channels (1 channel: 2016 points/system, 0.95 ms at 12 Mbps). |
| 3        | Shared memory of 512 Bytes (response speed: 2.36 ms) with A-net.  |
| 4        | Self-diagnostic function.   |



Website <http://www.algosystem.co.jp/>

I/O Module

WAGO Company of Japan, Ltd.

### WAGO-I/O-SYSTEM 750 Series

Model No. 750-346: Compatible with the 260IF-01 DeviceNet Communication Module

Model No. 750-352: Compatible with the 263IF-01 EtherNet/IP Communication Module and 218-01/02 Ethernet Communication Module.

WAGO-I/O-SYSTEM 750 series I/Os are module-type remote I/Os. Nodes can be constructed by combining a communication unit (bus coupler) with a function module of your choice. Various communication units that are compatible with a wide range of open fieldbus are available.

Yaskawa Electric's MP series machine controllers can be connected via DeviceNet, Ethernet/IP, and Modbus-TCP Ethernet networks. Instruction manuals contain information on easy ways to connect the machine controller.

Function modules are available for a wide range of I/O signal types: digital I/O (2 to 16 channels), analog I/O ( $\pm 10$  V, 0 to 20 mA, thermocouples), serial communications, counter I/O, etc.

Website <http://www.wago.co.jp/io>



Example of Node Configuration  
(Bus coupler + Module)

Related Products

Module for MP3300,  
and I/O Terminal

Anywire Corporation

### AnyWire DB Master Module

Model: AFMP-01

The AnyWire DB master module can be connected directly to the machine controllers in the MP3000 series. This module is equipped with the master functions of the AnyWire DB A40 series and is compatible with a variety of I/O terminals in the same series.

Features

- 1 The AnyWire system saves space and reduce costs because fewer cables are reduced and low-cost, general-purpose cables can be used. Time required for wiring is also reduced.
- 2 Highly efficient transmission is achieved with the Dual-Bus system. Analog inputs/outputs (128 words max) can be connected without adversely affecting the digital input/output signal transmission (512 points max).
- 3 General-purpose robot cables, cableveyor, slip rings can be used with the product. This is an ideal module to reduce wiring at drive sections



### CC-Link interface board

Models: AFMP-02-C, AFMP-02-CA

These slave interface boards connect the machine controllers in the MP3000 series to the CC-Link master. One CC-Link master can be connected to a maximum of 16 machine controllers in the MP3000 series through the CC-link when the PLC in the Q series (manufactured by Mitsubishi Electric Corporation) is used as a master station. Costs can be reduced and space saved by using the AFMP-02-CA board equipped with wire-saving DB ports.



### MECHATROLINK bit-type distributed I/O terminal

Model: AB023-M1

The MECHATROLINK bit-type distributed I/O terminal reduces the wiring required for drive systems that use MECHATROLINK-I and -II. The introduction of this I/O terminal into a MECHATROLINK open-network system significantly reduces total costs and increases system reliability because the MECHATROLINK I/O terminal can be used with any transmission media, such as robot cables and slip rings.

The AnyWire Bitty series for I/O terminals from AnyWire can be connected to this distributed I/O terminal to increase the flexibility in transmissions by supporting the connection of cables for signals from sensors and actuators in the system. It is possible to increase the number of I/O points to 432 by connecting I/Os with a bus that reduces the amount of wiring required.

Website <http://www.anywire.jp>



Main Partner Manufacturer

Sensor

RKC Instrument Inc.

### Module-type Digital Temperature Controller

Model: SRZ · Communications converter module COM-MY  
 · Temperature control module Z-TIO  
 · Digital I/O module Z-DIO

- Easily construct a multi-channel temperature control system by connecting the MECHATROLINK-compliant communications converter module to the temperature control modules.
- A single temperature control module can control temperatures of four points or two points. Also, 16 modules can be connected for temperature control of maximum 64 points.
- Digital I/O modules to output temperature alarms and to switch operation modes by using contact signals can also be connected.



Website <http://www.rkcinst.com>

Sensor

Azbil Corporation

### K1G Series High-accuracy Position Sensors

Model: MECHATROLINK-III-compatible K1G-C04M

Performance and functions that far exceed conventional norms, allowing you to make the measurements you want.

Features

- 1 See what you previously couldn't  
Minute variations not visible with conventional sensors can now be reliably detected.
- 2 Easily mounts anywhere  
Compact dimensions are achieved by slim sensor head design.
- 3 Less wasted time  
Comes with a full range of functions to help cut job time for design, installation, and maintenance.  
Support for MECHATROLINK-III also opens up a host of new applications and advantages.



Website <http://www.azbil.com>

Stepping Motor Drive

Oriental Motor Co., Ltd.

### Network Converter for Controlled Motors

Model: NETC01-M2 for MECHATROLINK-II  
 NETC01-M3 for MECHATROLINK-III

- These network converters convert the MECHATROLINK communication protocol to Oriental Motor's original RS-485 communication protocol. Oriental Motor's products that support the RS-485 protocol (up to 16 axes) can be controlled in MECHATROLINK communications.
- Only a single MECHATROLINK communication cable is required for wiring, reducing the number of wires and saving space.
- Parameters can be set by using an OPX-2A module or MEXE02 software (both sold separately.)



### AZ Series Multi-axis Driver for Motors Equipped with Mechanical Absolute Encoders

Model: AZD□A-KM3

- This  $\alpha$  STEP AZ series driver, for use with motors equipped with battery-free mechanical absolute encoders, now supports MECHATROLINK-III communications.
- Because an external sensor is not required, you can save on wiring and reduce maintenance.
- The motor will not miss steps, even under rapid load fluctuations or rapid acceleration, and highly responsive positioning is possible without tuning and hunting.
- AZ series DC power supply input motors and actuators can be connected to this multi-axis driver for two to four axes.

Website <http://www.orientalmotor.com>

## Slip Ring

## Endo Kogyo Co., Ltd.

## Slip ring for communications and control

Model: SRP-MLII-3

The SRP-ML slip ring enables communications with and control of drive units and systems that include rotating devices.

- Compact and highly durable structure
- Improved reliability with the new brush system that enables uninterrupted communications
- Connected directly by using MECHATROLINK-II cables

Website <http://www.endo-kogyo.co.jp/japanese/sr/con-index.html>



## Slip Ring

## Kyoei Electric Co., Ltd.

## Slip ring system for MECHATROLINK-II communications

Model: SRC120-MLII

This highly functional slip ring transmits data through MECHATROLINK communications from a fixed device to a rotating device.

- Can be packaged with a power device, such as power supply for a motor.
- Complies with RoHS Directive.

Website <http://www.kyoeidenki.jp>



## Slip Ring

## NSD Corporation

## Slip-ring system for MECHATROLINK-II communications

Model: 3TEφ17-7P

This slip-ring system achieves your intended measurements with unprecedented performance and functionality.

- Features
- 1 A small (43 mm dia. × 87 mm), lightweight slip-ring that supports MECHATROLINK-II communications.
  - 2 Can be used without maintenance for up to 50 million rotations at a maximum speed of 700 min<sup>-1</sup>.
  - 3 Can simultaneously supply power (200/220 VAC 3A) and transmit data. Power can also be supplied to a servo amplifier by combining this slip-ring with our slip-ring for high currents.

## Slip-ring system for MECHATROLINK-III communications

Model: 3TEφ17-5P-MIII

This slip-ring system achieves your intended measurements with unprecedented performance and functionality.

- Features
- 1 A small (43 mm dia. × 107 mm), lightweight slip-ring that supports MECHATROLINK-III communications.
  - 2 Can be used without maintenance for up to 50 million rotations at a maximum speed of 700 min<sup>-1</sup>.
  - 3 Power can also be supplied to a servo amplifier by combining this slip-ring with our slip-ring for high currents.

Website <http://www.nsdcorp.com>



# Connection Example MECHATROLINK-III

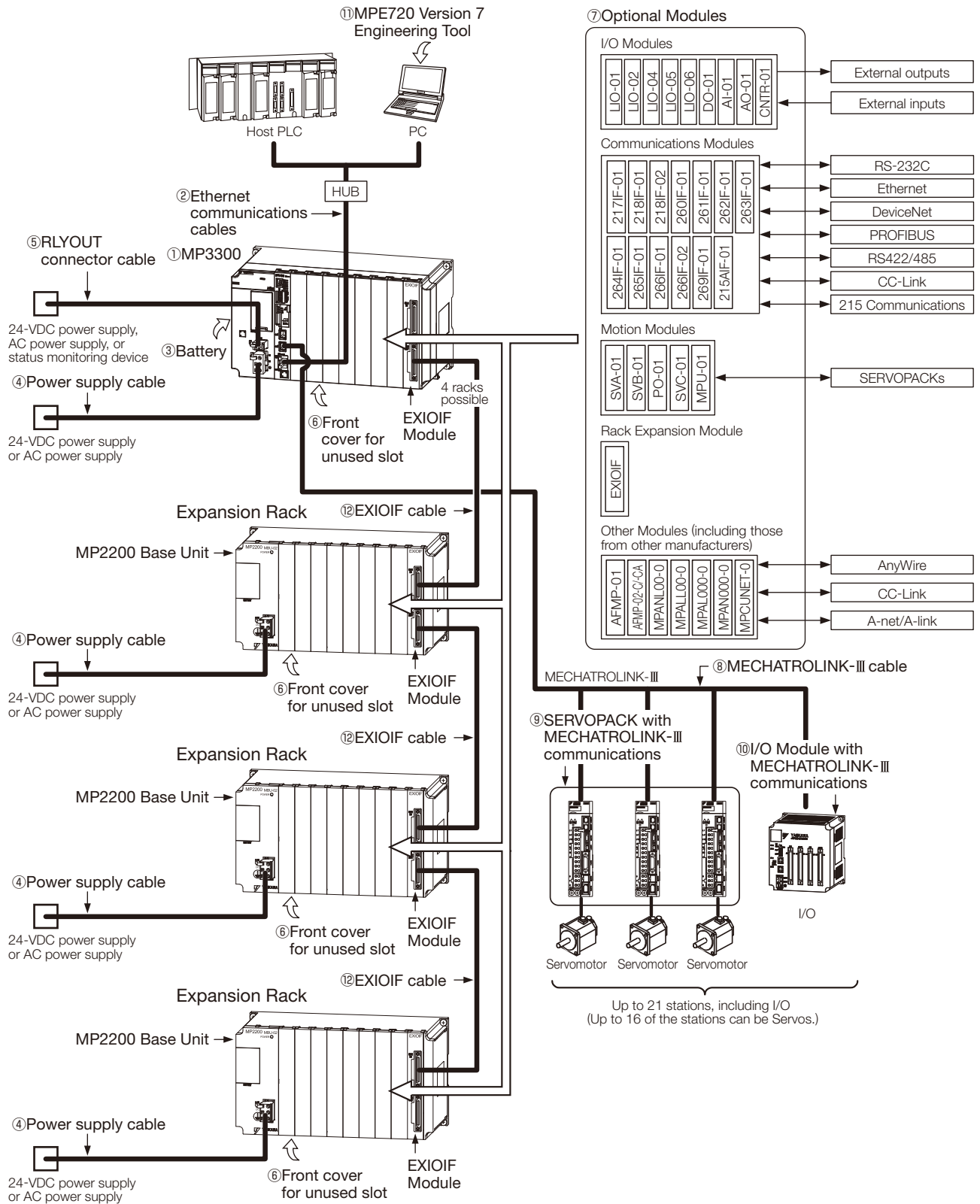

## ● Details of Components

No.	Name	Use	Model	Remarks	
①	MP3300 CPU module	Stores the module definitions and programs, and interprets the programs. The CPU unit also controls the optional modules.	Refer to page 25 for details.		
	Base unit	Used to mount optional modules.			
②	Ethernet communications cables	Used to connect the CPU unit to Ethernet communications devices or to connect the CPU unit to a PC that has the MPE720 installed on it.	—	Use a commercially available cable that meets the following conditions: · Ethernet specification: 100Base-TX · Category 5 or higher · Twisted-pair cable with RJ-45 connectors	
③	Battery with special connector	Provides power for the calendar and backup memory while the power is turned OFF.	JZSP-BA01	Supplied with the CPU module.	
④	Power supply cable	Connects the power supply unit to a 24-VDC power supply or an AC power supply.	—	Use a commercially available cable that meets the following conditions: · Wire size: AWG18 to AWG13 (0.8 mm <sup>2</sup> to 2.6 mm <sup>2</sup> ) · Twisted-pair cable	
⑤	RLYOUT connector cable	Connects the power supply unit to a 24-VDC power supply, an AC power supply, or a status monitoring device.	—	Use a commercially available cable that meets the following conditions: · Wire size: AWG28 to AWG14 (0.08 mm <sup>2</sup> to 2.0 mm <sup>2</sup> )	
⑥	Front cover for unused slot	Used to cover unused slots on the base unit.	JEPMC-OP3301-E	—	
⑦	Optional modules	Motion modules, I/O modules, and communications modules are selected based on the application.	Refer to pages 26 to 42 for details.		
⑧	MECHATROLINK-III cable	Connects the CPU unit to MECHATROLINK-III communications devices.	JEPMC-W6012-□□-E	Standard cable Length: 0.2 m to 50 m	
			JEPMC-W6013-□□-E	Cable with ferrite cores Length: 10 m to 50 m	
			JEPMC-W6014-□□-E	Cable with loose wires at one end Length: 0.5 m to 50 m	
⑨	SERVOPACK with MECHATROLINK-III communications	Used to control servomotors.	SGD7S-□□□□ 20□□□□	Σ-7-series AC SERVOPACK with MECHATROLINK-III communications	
			SGD7W-□□□□ 20□□□□		
⑩	I/O Modules with MECHATROLINK-III Communications	Used to input or output digital, analog, or pulse train signals.	64-point I/O module	JEPMC-MTD2310-E	24 VDC, 64 inputs, 64 outputs
			Analog input module	JEPMC-MTA2900-E	8 analog input channels
			Analog output module	JEPMC-MTA2910-E	4 analog output channels
			Pulse train input module	JEPMC-MTP2900-E	2 pulse-train inputs
			Pulse train output module	JEPMC-MTP2910-E	4 pulse-train outputs
⑪	MPE720 Version 7 Engineering Tool	Used to adjust and maintain AC Servo drives and inverters that are connected to the network.	CPMC-MPE780D	—	
⑫	EXIOIF cable	Connect the Base Unit and the Expansion racks or the Expansion racks each other by using the Expansion Interface Module. Note: Use the MP2200 base unit expansion rack (refer to page 26).	JEPMC-W2094-A5-E	Length: 0.5 m	
			JEPMC-W2094-01-E	Length: 1.0 m	
			JEPMC-W2094-2A5-E	Length: 2.5 m	

Item	Specification	
Environmental Conditions	Ambient Operating Temperature	0°C to 60°C
	Ambient Storage Temperature	-25°C to 85°C
	Ambient Operating Humidity	10% to 95% RH (with no condensation)
	Ambient Storage Humidity	10% to 95% RH (with no condensation)
	Pollution Level	Conforms to JIS B 3502 Pollution Degree 2.
	Corrosive Gas	There must be no combustible or corrosive gas.
	Operating Altitude	2,000 m max.
Mechanical Operating Conditions*	Vibration Resistance	Conforms to JIS B 3502. · Continuous vibration: 5 Hz to 8.4 Hz with single-amplitude of 1.75 mm 8.4 Hz to 150 Hz with fixed acceleration of 4.9 m/s <sup>2</sup> · Intermittent vibration: 5 Hz to 8.4 Hz with single-amplitude of 3.5 mm 8.4 Hz to 150 Hz with fixed acceleration of 9.8 m/s <sup>2</sup> 10 sweeps each in X, Y, and Z directions for both intermittent and continuous vibration
	Shock Resistance	Peak acceleration: 147 m/s <sup>2</sup> (15 G) Duration: 11 ms 3 times each in X, Y, and Z directions
Electrical Operating Conditions	Noise Resistance	Conforms to EN 55011 (Group 1 Class A), EN 61000-6-2, EN 61000-6-4.
Installation Conditions	Ground	Ground to 100 Ω max.
	Cooling Method	Natural cooling or forced-air cooling

\*: The conditions also at the time of transportation.

## ● Control Panel Cooling Method

The components that are used in the Machine Controller require the surrounding air temperature to be between 0°C and 60°C. Use one of the methods described below to ensure adequate cooling in the control panel.

Note: If the surrounding air temperature exceeds 55°C, we recommend forced-air cooling.

### Control Panels with Natural Cooling

- Do not mount the machine controller at the top of the control panel, where the hot air that is generated inside the panel collects.
- Leave sufficient space above and below the units, and maintain adequate distances from other devices, cable ducts, and other objects to ensure suitable air circulation.
- Do not mount the machine controller in any direction other than the specified direction.
- Do not mount the machine controller on top of any device that generates a significant amount of heat.
- Do not subject the machine controller to direct sunlight.

### Control Panels with Forced-air Cooling

For either of the following methods, install a fan near the center of and at the top or bottom of the Machine Controller.

- Forced draft method (A fan or a similar device is used to circulate the air in the interior and the exterior of the panel.)
- Forced circulation method (A fan or a similar device is mounted to the airtight panel to circulate the air inside.)

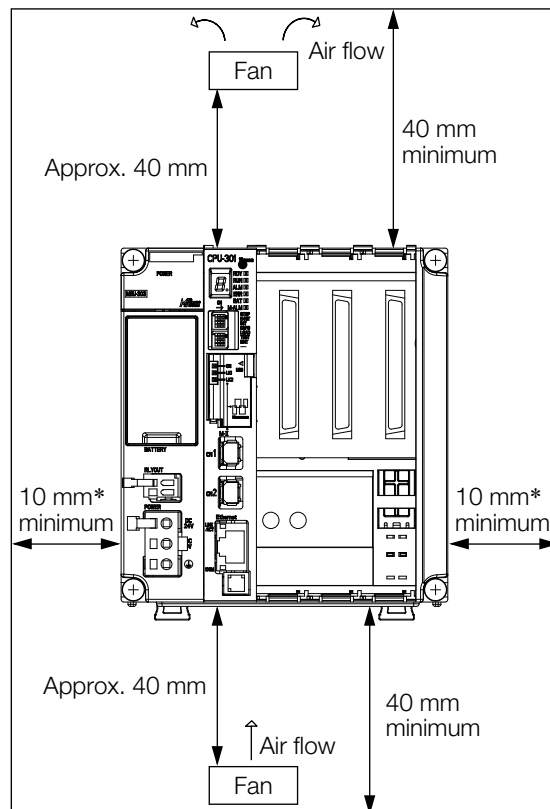

\*: 30 mm minimum except for MBU-304 base unit in the control panel with natural cooling



## ● MP3300 Base Unit (MBU-301/-302/-303/-304)



Model: JEPMC-BU3301-E, JEPMC-BU3302-E  
Approx. Mass: 700 g



Model: JEPMC-BU3303-E  
Approx. Mass: 500 g



Model: JEPMC-BU3304-E  
Approx. Mass: 400 g

Items		Specifications			
		8 Slots		3 Slots	1 Slot
Model (Abbreviation)		JEPMC-BU3301-E (MBU-301)	JEPMC-BU3302-E (MBU-302)	JEPMC-BU3303-E (MBU-303)	JEPMC-BU3304-E (MBU-304)
Power Supply	Input Voltage	100/200 VAC	24 VDC		
	Allowable Input Voltage Range	85 VAC to 132 VAC/170 VAC to 276 VAC	19.2 VDC to 28.8 VDC		
	Allowable Frequency Range	47 Hz to 63 Hz	-		
	Input Current	1.2/0.8 A max. (at rated input/output)	3.1 A max. (at rated input/output)	1.7 A (at rated input/output)	1.0 A max. (at rated input/output)
	Inrush Current	20 A, 10 ms max. (completely discharged, 132 VAC input, output rating) 50 A, 10 ms max. (completely discharged, 276 VAC input, output rating)	40 A, 10 ms max.		
	Allowable Momentary Power Loss Time	20 ms	1 ms		
	Rated Voltage	5.15 V			
	Rated Current	9.0 A		4.5 A	2.5 A
	Output Current Range	0.3 A to 9.0 A		0 A to 4.5 A	0 A to 2.5 A
	Constant Voltage Accuracy	5.15 V ±2% max. (5.05 V to 5.25 V)			
Slots for Optional Modules		8 Slots		3 Slots	1 Slot
Dimensions mm (W×H×D)		240×130×108		120×130×108	64×130×108

## ● CPU Module (CPU-301/-302)



Model: JAPMC-CP3301-□-E  
Approx. Mass: 200 g



Model: JAPMC-CP3302-□-E  
Approx. Mass: 300 g

Items	Specifications			
Model	JAPMC-CP3301-1-E	JAPMC-CP3301-2-E	JAPMC-CP3302-1-E*	JAPMC-CP3302-2-E*
Abbreviation	CPU-301 (16 axes)	CPU-301 (32 axes)	CPU-302 (16 axes)	CPU-302 (32 axes)
High-speed Scan	0.25 ms to 32.0 ms (in units 0.125 ms)		0.125 ms to 32.0 ms (in units 0.125 ms)	
Low-speed Scan	2.0 ms to 300.0 ms (in units of 0.5 ms)		2.0 ms to 300.0 ms (in units of 0.5 ms)	
Flash Memory	24 MB (15 MB of user memory)	40 MB (31 MB of user memory)	24 MB (15 MB of user memory)	40 MB (31 MB of user memory)
SRAM	4 MB	8 MB	4 MB	8 MB
DRAM	256 MB			
MECHATROLINK	<ul style="list-style-type: none"> <li>One circuit for MECHATROLINK-III ×2 ports</li> <li>Master function</li> <li>Slave function</li> </ul>			
Ethernet	10BASE-T/100BASE-TX ×1 port			
Calendar	Seconds, minutes, hour, day, week, month, year, day of week, and timing (battery backup)			
USB	<ul style="list-style-type: none"> <li>USB 2.0 Type-A host, 1 port</li> <li>Compatible devices: USB storage</li> </ul>			

\*: CPU-302 Module uses 2 slots, CPU Slot and Option Slot 1 for the Base Unit.

## Multiple-CPU Module (MPU-01)



Model: JAPMC-CP2700-E  
Approx. Mass : 86 g

The MPU-01 module has both CPU functions and the functions of a built-in SVC-01. This module is capable of control in complete synchronization with the main CPU and enables synchronization among MPU-01 modules.

Items	Specifications
Motion Network	MECATROLINK-III ×1 port
Max. Number of Controlled Axes	16 axes
High-speed Scan	0.25 ms, 0.5 ms to 32.0 ms (in units of 0.5 ms)
Low-speed Scan	2.0 ms to 300.0 ms (in units of 0.5 ms)
Program Memory Capacity	11.5 MB

## Connection Module

### ● Expansion Interface Module (EXIOIF)



Model: JAPMC-EX2200-E  
Approx. Mass: 80 g

Items	Specifications
Number of Expansion Racks	4 racks max.
Rack No.	Automatically identified

### ● MP2200 Base Units for Rack Expansion



Model: JEPMC-BU2200-E  
Approx. Mass: 665 g  
Model: JEPMC-BU2210-E  
Approx. Mass: 520 g



Model: JEPMC-BU2220-E  
Approx. Mass: 500 g

Items	Specifications		
	JEPMC-BU2200-E (MBU-01)	JEPMC-BU2210-E (MBU-02)	JEPMC-BU2220-E (MBU-03)
Power Supply	Input power voltage: 85 VAC to 132 VAC/198 VAC to 276 VAC Allowable Frequency Range: 47 Hz to 63 Hz Current consumption: 1.5 A or less with I/O rating Inrush current: 40 A or less when completely discharged, 275 VAC input, output rating Allowable power loss time: 20 ms	Input power voltage: 24 VDC ±20% Current consumption: 3.0 A or less with I/O rating Inrush current: 30 A or less when completely discharged, output rating Allowable power loss time: 1 ms	Input power voltage: 24 VDC ±20% Current consumption: 1.0 A or less with I/O rating Inrush current: 30 A or less when completely discharged, output rating Allowable power loss time: 1 ms
Motion Network	Not available for the base unit		
I/O Signals	Not available for the base unit		
Slot for Optional Modules	9 slots		4 slots
Expansion Configuration	Maximum of 4 base units can be connected using the EXIOIF.		
Dimensions (mm)	240 (W) × 130 (H) × 108 (D)		120 (W) × 130 (H) × 108 (D)

## Motion Modules

### ● MECHATROLINK-III Motion Module (SVC-01)



Model: JAPMC-MC2320-E  
Approx. Mass: 70 g

Items	Specifications
Communication Circuits	1 circuit
Communication Ports	2 ports
Terminator	Not required
Transmission Speed	100 Mbps
Communication Cycle	125 $\mu$ s, 250 $\mu$ s, 500 $\mu$ s, 1ms
Number of Connecting Stations	21 stations (16 axes for servo drives)/1 ms, 14 stations (14 axes for servo drives) /500 $\mu$ s, 8 stations (8 axes for servo drives) /250 $\mu$ s, 4 stations (4 axes for servo drives) /125 $\mu$ s
Retry Function	Available with MECHATROLINK-III
Slave Function	Available with MECHATROLINK-III
Transmission Distance	Distance between stations : 20 cm to 100 m

### ● MECHATROLINK-II Motion Module (SVB-01)



Model: JAPMC-MC2310-E  
Approx. Mass: 80 g

Items	Specifications
Communication Circuits	1 circuit
Communication Ports	2 ports
Terminator	External resistor (JEPMC-W6022 required)
Transmission Speed	10 Mbps
Communication Cycle	0.5 ms, 1 ms, 1.5 ms, 2 ms
Number of Connecting Stations*	21 stations (16 axes for servo drives) /2 ms, 15 stations (15 axes for servo drives) /1.5 ms, 9 stations (9 axes for servo drives) /1 ms, 4 stations (4 axes for servo drives) /0.5 ms
Retry Function	Available with MECHATROLINK-II
Slave Function	Available with MECHATROLINK-II
Transmission Distance	See "MECHATROLINK-II Repeater" on page 43.

\*: MECHATROLINK-II (32-byte mode)

### ● Analog Output Motion Module (SVA-01)

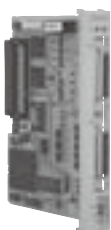

Model: JAPMC-MC2300-E  
Approx. Mass: 100 g

Items	Specifications
Number of Controlled Axes	2
Analog Output	2 channels/1 axis, -10 V to +10 V, 16-bit D/A
Analog Input	2 channels/1 axis, -10 V to +10 V, 16-bit A/D
Pulse Input	1 channel/1 axis, 5-V differential inputs, phase A/B pulse, and 4 Mpps (16 Mpps with 4 multipliers)
Input Signals	6 points/1 axis, 24 VDC, 4 mA, and source mode or sink mode input
Output Signals	6 points/1 axis, 24 VDC, 100 mA, open collector, and sink mode output

### ● Pulse Output Motion Module (PO-01)



Model: JAPMC-PL2310-E  
Approx. Mass: 100 g

Items	Specifications
Number of Controlled Axes	4
Pulse Output	Output Method : CW/CCW, sign + pulse, and phase A/B Maximum Frequency: 4 Mpps with CW/CCW or sign + pulse, 1 Mpps with phase A/B (before multiplication) Interface : 5-V differential outputs
Digital Input	5 points $\times$ 4 channels, source mode input DI_0 : Separate for each power supply... 5 V/3.9 mA, 12 V/10.9 mA, 24 V/4.1 mA DI_1 to DI_4: Power supply shared ... 24 V/4.1 mA
Digital Output	4 points $\times$ 4 channels Open collector (sink mode) output (24 V/100 mA)
Current Consumption	5 V, 1.0 A max.

## Communication Modules

### ● General-purpose Serial Communication Module (217IF-01)



Model: JAPMC-CM2310-E  
Approx. Mass: 100 g

#### For RS-232C Communication

Items	Specifications
Interface	One port
Connector	D-sub 9 pins (Female)
Max. Transmission Distance	15 m
Max. Transmission Speed	76.8 kbps*
Access Mode	Asynchronous (Start-stop synchronization)
Communication Protocols	MEMOBUS (Master or Slave), MELSEC (A-compatible 1C frame, type: 1), OMRON (only for host mode), Non-procedure
Media Access Control Method	1:1
Transmission Format (Can be set)	Data bit length: 7 or 8 bits Stop bits: 1 or 2 bits Parity bits: Even, odd, or none

\* : Connection may not be possible depending on the characteristics of the connected devices. If connection is not possible, decrease the setting of the baud rate.

#### For RS-422/485 Communication

Items	Specifications
Interface	One port (RS-422 or -485)
Connector	MDR 14 pins (Female)
Max. Transmission Distance	300 m
Max. Transmission Speed	76.8 kbps
Access Mode	Asynchronous (Start-stop synchronization)
Communication Protocols	MEMOBUS (Master or Slave), MELSEC (A-compatible 1C frame, type: 1), OMRON (only for host mode), Non-procedure
Media Access Control Method	1:1 (RS-422), 1: N (RS-485)*
Transmission Format (Can be set)	Data bit length: 7 or 8 bits Stop bits: 1 or 2 bits Parity bits: Even, odd, or none

\* : N: 31 units maximum

### ● Ethernet Communication Module (218IF-01/-02)



218IF-01 Module  
Model: JAPMC-CM2300-E  
Approx. Mass: 90 g

#### For Ethernet Communication

Items	Specifications
Interface	One port (10BASE-T for 218IF-01, 100BASE-TX/10BASE-T for 218IF-02) (RJ-45 modular jack)
Max. Segment Length	100 m
Transmission Speed	218IF-01: 10 Mbps, 218IF-02: 100 Mbps/10 Mbps
Access Mode	IEEE802.3, CSMA/CD
Connections	TCP/UDP/IP/ARP/ICMP
Max. Number of Words in Transmission	218IF-01: 512 words, 218IF-02: 2046 words
Communication Protocols	Extended MEMOBUS, MEMOBUS, MELSEC (A-compatible 1E frame), Non-procedure, MODBUS/TCP
Max. Number of Connections	20 stations

#### For RS-232C Communication

Items	Specifications
Interface	One port
Connector	D-sub 9 pins (Female)
Max. Transmission Distance	15 m
Max. Transmission Speed	19.2 kbps (Using 218IF-01), 115.2 kbps (Using 218IF-02)
Access Mode	Asynchronous (Start-stop synchronization)
Communication Protocols	MEMOBUS (Master or Slave), MELSEC (A-compatible 1C frame, type: 1), OMRON (only for host mode), Non-procedure
Media Access Control Method	1:1
Transmission Format (Can be set)	Data bit length: 7 or 8 bits Stop bits: 1 or 2 bits Parity bits: Even, odd, or none



218IF-02 Module  
Model: JAPMC-CM2302-E  
Approx. Mass: 90 g

## ● DeviceNet Communication Module (260IF-01)

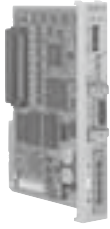

Model: JAPMC-CM2320-E  
Approx. Mass: 90 g

### For DeviceNet Communication

Items		Specifications
Number of Circuits		1
Applicable Communication		Conforms to DeviceNet · I/O transmission (polled I/O and bit-strobed I/O) · Explicit messaging
I/O Communication	Max. Number of Slaves	63 nodes
	Max. I/O Bytes	2048 bytes, 256 bytes per node
Message Communication (Only for Master)	Max. Number of Nodes	63 nodes Synchronous communications possible: 4 nodes
	Max. Message Length	256 bytes
	Executed Functions	MSG-SND function
Switches on the Front		Two rotary switches: Node address settings DIP switch: Settings for transmission speed and switching master or slave
Indicators		2 LEDs: MS and NS
Power Voltage for Communication		24 VDC $\pm$ 10% (Using the specially designed cable)
Max. Current Consumption		Communication power: 45 mA (Supplied by transmission connectors) Internal circuit power supply (supplied from Basic Module).

### For RS-232C Communication

Items	Specifications
Interface	One port
Connector	D-sub 9 pins (Female)
Max. Transmission Distance	15 m
Max. Transmission Speed	19.2 kbps
Access Mode	Asynchronous (Start-stop synchronization)
Communication Protocols	MEMOBUS (Master or Slave), MELSEC (A-compatible 1C frame, type: 1), OMRON (only for host mode), Non-procedure
Media Access Control Method	1:1
Transmission Format (Can be set)	Data bit length: 7 or 8 bits Stop bits: 1 or 2 bits Parity bits: Even, odd, or none

## ● PROFIBUS Communication Module (261IF-01)



Model: JAPMC-CM2330-E  
Approx. Mass: 90 g

### For PROFIBUS Communication

Items	Specifications
Functions	DP slave, Cyclic communication (DP standard function)
Transmission Speed	12 M/6 M/4 M/3 M/1.5 M/750 k/500 k/187.5 k/93.75 k/19.2 k/9.6 kbps (Automatic detection)
Configuration	By PROFIBUS Master
Slave Address	1 to 64
I/O Processing	I/O assignments: 61 words max. each for inputs and outputs
Diagnostic Functions	Status and Slave status display using MPE720 I/O error display using system register

### For RS-232C Communication

Items	Specifications
Interface	One port
Connector	D-sub 9 pins (Female)
Max. Transmission Distance	15 m
Max. Transmission Speed	19.2 kbps
Access Mode	Asynchronous (Start-stop synchronization)
Communication Protocols	MEMOBUS (Master or Slave), MELSEC (A-compatible 1C frame, type: 1), OMRON (only for host mode), Non-procedure
Media Access Control Method	1:1
Transmission Format (Can be set)	Data bit length: 7 or 8 bits Stop bits: 1 or 2 bits Parity bits: Even, odd, or none

## ● FL-net Communication Module (262IF-01)



Model: JAPMC-CM2303-E  
Approx. Mass: 80 g

For 262IF-01 Communication

Items		Specifications		
FL-net Transmission	Transmission Specifications*1	Interface	100BASE-TX      10BASE-T	
		Transmission Mode	Full duplex or half duplex	
		Transmission Speed	100 Mbps      10 Mbps	
		Max. Segment Length	100 m between hub and nodes if UTP cables are used	
		Connector	RJ-45 connector	
		Auto Negotiation	Supported (Transmission speed and communication mode cannot be fixed.)	
	Cyclic Communication Specifications	Max. Number of Nodes	254 nodes max. if repeaters are used (Only 64 nodes, including the local node, can be allocated.)*2	
		Data Size	Max. data size within network Area 1 (Bit data) : 8 kbits    Area 2 (Word data) : 8 kwords Max. data size per station (node) Area 1 + Area 2 : 8 kbits + 8 kwords can be allocated.	
		Media Access Control Method	N : N	
	Message Communication Specifications	Number of Message Channels	10	
		Engineering Communication	None	
		Message Service	Read Word Block, Write Word Block, Read Network Parameter, Write Network Parameter*3, Change Other Node to Stop Mode*3, Change Other Node to Run Mode*3, Read Profile, Transmissive Message, Read Log Data, Clear Log Data, Return Message	
Number of Transmission Words		512 words max.		

\*1 : Conforms to Ethernet specifications

\*2 : The number of nodes that the 262IF-01 can allocate to I/O is limited to 64, including the local node, in accordance with the specifications of the MP series Machine Controllers.

\*3 : Supported by client nodes only. (In FL-net communications, the node sending data is called the client, and the node receiving data is called the server.)

## ● EtherNet / IP Communication Module (263IF-01)



Model: JAPMC-CM2304-E  
Approx. Mass: 80 g

For 263IF-01 Communication

Items		Specifications		
EtherNet / IP Transmission	Transmission Specifications*1	Interface	100BASE-TX      10BASE-T	
		Transmission Mode	Full duplex or half duplex	
		Transmission Speed	100 Mbps      10 Mbps	
		Max. Segment Length	100 m between hub and nodes if UTP cables are used	
		Connector	RJ-45 connector	
		Auto Negotiation	Supported (Transmission speed and communication mode cannot be fixed.)	
	I/O Communication Specifications	Max. Number of Connectable I/O Devices	64 units (Does not include the devices used for explicit message communication)*2	
		Max. Number of I/O Bytes	Max. Number of I/O Bytes within the network Inputs/outputs : 8192 bytes each per system (Total number of bytes of I/O data exchanged among all connected devices) Inputs/outputs : 500 bytes each per device	
		Communication Mode	Scanner and adapter	
	Explicit Message Communication Specifications	Max. Number of Connectable Devices for Explicit Message Communication	64 units (Number of devices that can communicate simultaneously : 10)*2	
		Number of Message Channels	10	
		Max. Number of Message Bytes	504 bytes	
Communication Mode		Client and server		
	Connection Type	Unconnected type (UCMM) When the module functions as a server, connected type (class 3) is also supported.		

\*1 : Conforms to Ethernet specifications

\*2 : Max. Number of connectable devices is based on the specifications of the MP series Machine Controllers.

## ● EtherCAT Communication Module (264IF-01)



Model: JAPMC-CM2305-E  
Approx. Mass: 100 g

### For 264IF-01 Communication

Items		Specifications	
EtherCAT Transmission	Transmission Specifications	Transmission Mode	Full duplex
		Transmission Speed	100 Mbps
		Distance between Nodes	100 m
		Connector	RJ-45 connector, 2 ports (1 circuit)
		Cable	CAT 5e STP cable Straight or cross cable
		Topology	Line topology (structure)
		Functions	As a slave station of EtherCAT
	Address	Automatic allocation by Master	
	Process Data Communications (Cyclic)	Supported Protocol	EtherCAT standard (Protocols such as CoE, SoE, and VoE are not supported.)
		Data Size	Input data : 198 words max. Output data : 198 words max. Input data + Output data : 200 words max. in total
		Media Access Control Method	Between master and slave (1 : 1)
		Communication Cycle	According to the configuration of Master
	Mailbox Communication (Message)	Supported Protocol	EtherCAT standard (Protocols such as CoE, EoE, FoE, SoE, and VoE are not supported.)
Message Service		System message only (Cannot use user messages such as read/write memory.)	

## ● CompoNet Communication Module (265IF-01)



Model: JAPMC-CM2390-E  
Approx. Mass: 80 g

### For CompoNet Communication

Items		Specifications
Number of Circuits		1
Applicable Communication		I/O communication, message communication
Transmission Speed		4 Mbps, 3 Mbps, 1.5 Mbps, 93.75 kbps
Master/Slave		Master
Conditions of Use for Repeater Units		Up to 64 units can be connected in one network. Lines can be extended a maximum of two levels from the master unit using repeater units.
I/O Communication	Max. Number of Slaves	384 nodes
	Max. I/O Bytes	32 bytes per node
Message Communication	Max. Number of Nodes	384 nodes Synchronous communications possible: 10 nodes
	Max. Message Length	256 bytes
	Executed Functions	MSG-SND function
Switches on the Front		DIP switch: Transmission speed
Indicators		4 LEDs: MS, NS, TX, RX
Power Voltage for Communication		24 VDC $\pm$ 10% (Using the specially designed cable)

## ● PROFINET Communication Master Module (266IF-01)\*

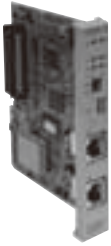

Model: JAPMC-CM2306-E  
Approx. Mass: 100 g

For PROFINET Communication

Items	Specifications
Real-time Class	RT_CLASS_1
PROFINET IO Conformance Class	Conformance Class-B
Transmission Speed	100 Mbps
Max. Transmission Distance	100 m/segment (between nodes)
Max. Number of Connecting Stations	128
Communication Cycle	1, 2, 4, 8, 16, 32, 64, 128, 256, or 512 (unit: ms)
Max. Transmission Size	1024 bytes/station Input: 5712 bytes; Output: 5760 bytes

\*: Estimates are required before ordering this product. Contact your Yaskawa representative for more information.

## ● PROFINET Communication Slave Module (266IF-02)



Model: JAPMC-CM2307-E  
Approx. Mass: 100 g

For PROFINET Communication

Items	Specifications
Real-time Class	RT_CLASS_1
PROFINET IO Conformance Class	Conformance Class-B
Transmission Speed	100 Mbps
Max. Transmission Distance	100 m/segment (between nodes)
Max. Number of Connecting Stations	–
Communication Cycle	Same as master module
Max. Transmission Size	Input: 1024 bytes; Output: 1024 bytes

## ● CC-Link IE Field Slave Module (269IF-01)



Model: JAPMC-CM2308-E  
Approx. Mass: 90 g

CC-Link Communications Specifications

Items	Specifications	
CC-Link IE Field Basic Communications Specifications	Transmission Speed	1 Gbps
	Communications Method	Token passing
	Link Scan Time Control	Fixed or best effort (specified at master station)
	Synchronization	None
	Number of Nodes Connected on One Network	254 (total for masters and slaves)
	Maximum Distance between Nodes	100 m
	Maximum Number of Branches	If on the same Ethernet network, no upper limit.
	Topologies	Line, star, line+star, or ring
269IF-01 Module Communications Specifications	MAC Address	One station occupied.
	Station Type	Intelligent device station
	Station Numbers	1 to 120
	Supported	Transmission control: Supported Cyclic transmissions: Supported Transient transmissions: Supported Synchronized control: Not supported
	Number of Link Points	Maximum Number of Linked Words and Bits in Network: 16,384 bits (RX, RY), 8,192 words (RWw, RWr) Maximum Number of Linked Words and Bits Per 269IF-01 Module Station: 2,048 bits (RX, RY), 1,024 words (RWw, RWr)
	Message Communications	960 bytes max. per channel
Number of Message Channels	2 channels (Simultaneous execution is possible.)	

Note: For details of the 269IF-01 Module, refer to the User's Manual (Manual No.: SIEPC88070049).

The following definitions are used in relation to CC-Link slave station.

- RX: Bit data that is sent from a slave station to the master station.
- RY: Bit data that is received at a slave station from the master station.
- RWr: Word data that is sent from a slave station to the master station.
- RWw: Word data that is received at a slave station from the master station.



## ● MPLINK Communication Module (215AIF-01 MPLINK)

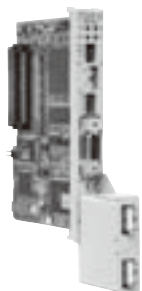

Model: JAPMC-CM2360-E  
Approx. Mass: 130 g

### For MPLINK Communication

Items	Specifications
Transmission Method	MPLINK
Interface	One port
Connector	USB port with T-branch connector*
Cable	MECHATROLINK cable (JEPMC-W6002-□□)
Transmission Speed	10 Mbps
Max. Transmission Distance	50 m: 16 stations 100 m: 32 stations (With MECHATROLINK-II JEPMC-REP2000 repeater)
Max. Number of Words in Link Transmission	4096 words per circuit. 1024 words per station.
Media Access Control Method	N : N
Max. Number of Connecting Stations	16 stations (32 stations with repeater)
Relay Function	Available

\*: A T-branch connector is included in the package. Spares can also be ordered separately. (Model: JEPMC-OP2310)

### For RS-232C Communication

Items	Specifications
Interface	One port
Connector	D-sub 9 pins (Female)
Max. Transmission Distance	15 m
Max. Transmission Speed	19.2 kbps
Access Mode	Asynchronous (Start-stop synchronization)
Communication Protocols	MEMOBUS (Master or Slave), MELSEC (A-compatible 1C frame, type: 1), OMRON (only for host mode), Non-procedure
Media Access Control Method	1:1
Transmission Format (Can be set)	Data bit length: 7 or 8 bits Stop bits: 1 or 2 bits Parity bits: Even, odd, or none

## ● CP-215 Communication Module (215AIF-01 CP-215)



Model: JAPMC-CM2361\*1  
Approx. Mass: 130 g

### For CP-215 Communication

Items	Specifications
Transmission Method	CP-215
Interface	One port
Connector	USB port with MR connector converter*2
Cable	No ready-made cable available. See page 55 for details on cable specifications.
Transmission Speed	2 Mbps / 4 Mbps
Max. Transmission Distance	270 m at 2 Mbps and 170 m at 4 Mbps.
Max. Number of Words in Link Transmission	2048 words per circuit. 512 words per station.
Media Access Control Method	N : N
Max. Number of Connecting Stations	32 stations (64 stations with repeater)
Relay Function	Available

\*1 : Cannot be mounted in the slot to the left of 260IF-01. JAPMC-CM2361 modules cannot be mounted side by side.

\*2 : An MR connector converter is included in the package. Spares can also be ordered separately. (Model: JEPMC-OP2320)

### For RS-232C Communication

Items	Specifications
Interface	One port
Connector	D-sub 9 pins (Female)
Max. Transmission Distance	15 m
Max. Transmission Speed	19.2 kbps
Access Mode	Asynchronous (Start-stop synchronization)
Communication Protocols	MEMOBUS (Master or Slave), MELSEC (A-compatible 1C frame, type: 1), OMRON (only for host mode), Non-procedure
Media Access Control Method	1:1
Transmission Format (Can be set)	Data bit length: 7 or 8 bits Stop bits: 1 or 2 bits Parity bits: Even, odd, or none

## I/O Modules

### ● I/O Modules (LIO-01/-02)



LIO-01 Module  
Model: JAPMC-IO2300-E  
Approx. Mass: 80 g



LIO-02 Module  
Model: JAPMC-IO2301-E  
Approx. Mass: 80 g

#### Digital I/O for LIO-01/-02 Modules

Items	Specifications
Input Signals	16 points (All connected) and 24 VDC $\pm$ 20%, 5 mA (TYP) Sink mode or source mode input and photocoupler isolation Min. ON voltage/current: 15 V/2.0 mA Max. OFF voltage/current: 5 V/1.0 mA Max. Response time: OFF $\rightarrow$ ON 0.5 ms and ON $\rightarrow$ OFF 0.5 ms Interruption (DI-00): DI-00 can be used for interruptions. If an interruption is enabled, the interrupt drawing is started when DI-00 is set to ON. Pulse latch (DI-01): DI-01 can be used for pulse latching. If pulse latching is enabled, the pulse counter is latched when DI-01 is set to ON.
Output Signals	16 points (All connected) and 24 VDC $\pm$ 20%, 100 mA max. Open collector: sink mode output (LIO-01 module) source mode output (LIO-02 module) Photocoupler isolation and Max. OFF current: 0.1 mA Max. Response time: OFF $\rightarrow$ ON 1 ms and ON $\rightarrow$ OFF 1 ms Output protection : Fuse (for protection against fires caused by an overcurrent when outputting after a short circuit occurred) If circuit protection is required, provide a fuse for each output circuit.

#### Pulse Input for LIO-01/-02 Modules

Items	Specifications
Number of Channels	1 (Phase A, B, or Z input)
Input Circuit	Phase A/B: 5 V differential inputs, no insulation, and max. frequency 4 MHz Phase Z: 5 V/12 V photocoupler inputs and max. frequency 500 kHz
Input Method	A/B (1,2, or 4 multipliers), sign (1 or 2 multipliers), UP/DOWN (1 or 2 multipliers)
Latch Input	Pulse latch with phase Z or DI-01 Max. Response time: 1 $\mu$ s when input with phase Z; 60 $\mu$ s when input with DI-01
Others	Coincident detection; Preset and clear functions for counter values

### ● I/O Modules (LIO-04/-05)

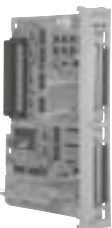

LIO-04 Module  
Model: JAPMC-IO2303-E  
Approx. Mass: 80 g



LIO-05 Module  
Model: JAPMC-IO2304-E  
Approx. Mass: 80 g

Items	Specifications
Input Signals	32 points (8 points connected) and 24 VDC $\pm$ 20%, 4.1 mA (TYP) Sink mode or source mode input and photocoupler isolation Min. ON voltage/current: 15 V/2.0 mA Max. OFF voltage/current: 5 V/1.0 mA Max. Response time: OFF $\rightarrow$ ON 0.5 ms and ON $\rightarrow$ OFF 0.5 ms Interruption (DI-00, DI-01, DI-16, DI-17): DI-00, DI-01, DI-16, and DI-17 can be used for interruptions. If an interruption is enabled, the interrupt drawing is started when DI-00, DI-01, DI-16, or DI-17 is set to ON.
Output Signals	32 points (8 points connected) and 24 VDC $\pm$ 20%, 100 mA max. Open collector: sink mode output (LIO-04 module), source mode output (LIO-05 module) Photocoupler isolation and Max. OFF current: 0.1 mA Max. Response time: OFF $\rightarrow$ ON 0.5 ms and ON $\rightarrow$ OFF 1 ms Output protection: Fuse (for protection against fires caused by an overcurrent when outputting after a short circuit occurred) If circuit protection is required, provide a fuse for each output circuit.

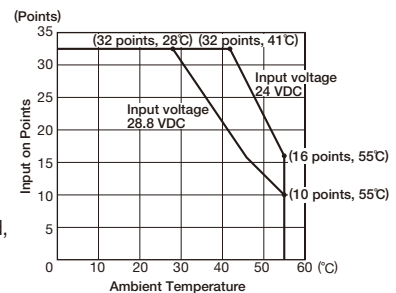

Note: See right for the derating conditions.

## ● I/O Module (LIO-06)



Model: JAPMC-IO2305-E  
Approx. Mass: 80 g

LIO-06 Module Specifications

Items	Specifications	
Digital Input Signals	Number of Input Points	8
	Input Method	Sink mode/source mode
	ON Voltage/Current	15 VDC min./2 mA min.
	OFF Voltage/Current	5 VDC max./1 mA max.
	Max. Response Time	OFF → ON: 0.5 ms max., ON → OFF: 0.5 ms max.
	Number of Common Points	1
Digital Output Signals	Number of Output Points	8
	Output Method	Sink mode
	External Voltage	19.2 VDC to 28.8 VDC
	Output Current	100 mA/point
	ON Voltage	1 V max.
	Current Leakage while OFF	0.1 mA max.
	Max. Response Time	OFF → ON: 0.25 ms max., ON → OFF: 1 ms max.
	Number of Common Points	1
Analog Input Signals	Analog Input Range	-10 V to +10 V
	Number of Channels	1
	Input Impedance	Approx. 20 kΩ
	Input Voltage Characteristics	±10 V (±31276) Resolution: 16 bits
Analog Output Signals	Analog Output Range	-10 V to +10 V
	Number of Channels	1
	Output Voltage Characteristics	±10 V (±31276) Resolution: 16 bits
Pulse Counter	Number of Channels	1
	Counter Mode	Reversible counter
	A/B Pulse Signal Form	5-V differential input
	A/B Pulse Signal Polarity	Positive logic/negative logic
	Pulse Counting Methods	Sign (Multiplier: 1 or 2) UP/DOWN (Multiplier: 1 or 2) A/B pulse (Multiplier: 1, 2, or 4)
	Max. Frequency	4 MHz
	Number of Latch Input Points	Can be selected from two points (Phase-Z latch or DI latch) Response time: 1 μs max. at phase-Z input, 60 μs max. at DI_01 input
	Coincidence Detection Function	Available (Output terminal: DO_07)
	Coincident Interruption	Available

## ● Output Module (DO-01)



Model: JAPMC-DO2300-E  
Approx. Mass: 80 g

Items	Specifications
Number of Output Points	64
Output Method	Transistor or open collector: sink mode output
Isolation	Photocoupler isolation
Output Voltage	24 VDC (19.2 V to 28.8 V)
Max. Output Current	100 mA
Max. OFF Current	0.1 mA
Max. Response Time	OFF → ON: 0.5 ms / ON → OFF: 1 ms
Number of Common Points	8
Protective Circuit	Fuse for common circuits
Fuse Rating	1 A
Error Detection	Fuse blowout detection

## ● Analog Input Module (AI-01)

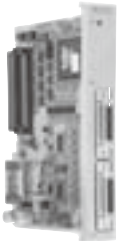

Model: JAPMC-AN2300-E  
Approx. Mass: 100 g

Items	Specifications
Analog Input Range	-10 V to +10 V      0 mA to 20 mA
Number of Channels	8 [(4 channels/connector)×2]
Number of Channels to be Used	1 to 8
Isolation	Between channels: Not isolated, Between input connector and system power supply: Photocoupler isolation
Max. Rated Input	±15 V      ±30 mA
Input Impedance	20 kΩ      250 Ω
Resolution	16 bits (-31276 to +31276)      15 bits (0 to +31276)
Accuracy (0°C to 55°C)	±0.3% (±30 mV)*      ±0.3% (±0.06 mA)*
Input Conversion Time	1.4 ms max.
Current Consumption	5 V, 500 mA

\*: After offset and gain adjustment by MPE720.

## ● Analog Output Module (AO-01)



Model: JAPMC-AN2310-E  
Approx. Mass: 90 g

Items	Specifications
Number of Channels	4
Number of Channels to be Used	1 to 4
Isolation	Between channels: Not isolated, Between input connector and system power supply: Photocoupler isolation
Analog Output Range	-10 V to +10 V      0 V to +10 V
Resolution	16 bits (-31276 to +31276)      15 bits (0 to +31276)
Maximum Allowable Load Current	±5 mA
Accuracy	25°C      ±0.1% (±10 mV)
	0°C to 55°C      ±0.3% (±30 mV)
Output Delay Time	1.2 ms*
Current Consumption	5 V, 800 mA max.

\*: After change with a full scale of -10 V to +10 V.

## ● Counter Module (CNTR-01)



Model: JAPMC-PL2300-E  
Approx. Mass: 85 g

Items	Specifications
Number of Channels	2
Input Circuit (Selected by software)	5-V differential: 4-MHz response frequency (RS-422, not isolated) 12 V: 120-kHz response frequency (12 V, 7 mA, current source mode input, and photocoupler isolation)
Input Method	A/B (1, 2, or 4 multipliers), UP/DOWN (1 or 2 multipliers), and sign (1 or 2 multipliers)
Counter Functions	Reversible counter, interval counter, and frequency measurement
Maximum Frequency	4 MHz with 5-V differential input (16 MHz with 4 multipliers)
Coincident Interruption	Simultaneous output to CPU module via system bus and output module.
Coincident Output	2 points, 24 V, 50 mA, current sink mode input, and photocoupler isolation
DO Output	2 points, 24 V, 50 mA, current sink mode input, and photocoupler isolation (zone output, speed-coincidence output, and frequency-coincidence output)
PI Latch Input	2 points, 24 V, source mode input, and photocoupler isolation
Current Consumption	5 V, 600 mA

## MECHATROLINK-III Compatible Modules

### ● Hub Module



Model: JEPMC-MT2000-E  
Approx. Mass: 800 g

Items	Specifications
Data Transfer Method	MECHATROLINK-III
Transmission Speed	100 Mbps
Transmission Medium	MECHATROLINK-III cable, model : JEPMC-W6012-□□-E
Number of MECHATROLINK Ports	Master-side port : 1 (CNM1) to connect the master station Slave-side port : 8 (CNS1 to CNS8) to connect slave stations
Arbitration	FIFO arbitration discipline Error when multiple slave-side ports receive data at the same time
Transmission Delay Time between Ports	600 ns (typ)
Indicators	1 indicator for power supply ON/OFF, 9 indicators for port link status
External Power Supply	24 VDC ( $\pm 20\%$ ), 0.5 A
Installation Orientation	Vertical or horizontal
Exterior	Painted

### ● MECHATROLINK Compatible Gateway Module (GW3100)



Model: JEPMC-GW3100-E  
Approx. Mass: 200 g

Items	Specifications	
Power Supply	Input Voltage	24 VDC
	Allowable Input Voltage Range	19.2 VDC to 28.8 VDC
	Current Consumption	1 A max.
	Inrush Current	40 A, 10 ms max.
Motion Network	One circuit for MECHATROLINK-III Transmission speed: 100 Mbps Transmission cycle: 0.25 ms to 8 ms	
	One circuit for MECHATROLINK-II Transmission speed: 10 Mbps Terminator: built-in	
USB	1 port	

### ● 64-point I/O Module



Model: JEPMC-MTD2310-E  
Approx. Mass: 550 g

Items	Specifications
I/O Signals	Input: 64 points, 24 VDC, 5 mA, sink/source mode input Output: 64 points, 24 VDC, 50 mA when all points ON* sink mode output
External Power Supply	24 VDC (19.2 V to 28.8 V) Rated current: 0.5 A

\* : The max. rating is 100 mA per point (depending on derating conditions).

## ● Analog Input Module (MTA2900)



Model: JEPMC-MTA2900-E  
Approx. Mass: 300 g

Items		Specifications			
Analog Input	Analog Input Range	-10 V to +10 V	0 V to +10 V	0 mA to 20 mA	
	Number of Channels	8 [(4 channels/connector) × 2]			
	Number of Channels to be Used	1 to 8			
	Isolation	Between channels: Not isolated			
	Max. Rated Input	± 15 V		± 30 mA	
	Input Impedance	20 kΩ		250Ω	
	Resolution	16 bits (-31276 to +31276)	15 bits (0 to +31276)		
	Absolute Accuracy *1	100 mV max.		0.3 mA max.	
	Accuracy	25°C *2	±0.1% (±10 mV)	±0.1% (±0.02 mA)	
		0 to 55°C	±0.3% (±30 mV)	±0.3% (±0.06 mA)	
Input Conversion Time *3	1.4 ms max.				
Motion Network	Two circuits for MECHATROLINK-III Transmission distance : 20 cm to 100 m		Transmission speed : 100 Mbps Terminator : not required		
External Power Supply	24 VDC (19.2 V to 28.8 V), 500 mA max.				

\* 1 : Indicates the values if the offset and gain are not adjusted.

\* 2 : Indicates the values if the offset and gain are adjusted.

\* 3 : Input conversion time = Delay caused by input filter (1 ms max.) + (50 μs × Number of channels used)  
Delay time caused by the input filter peaks at 1 ms between -10 V and +10 V.

Note: Use a 24-VDC power supply and external input power supply with double or reinforced insulation.

## ● Analog Output Module (MTA2910)



Model: JEPMC-MTA2910-E  
Approx. Mass: 300 g

Items		Specifications		
Analog Output	Analog Output Range	-10 V to +10 V	0 V to +10 V	
	Number of Channels	4		
	Number of Channels to be Used	1 to 4		
	Isolation	Between channels: Not isolated		
	Resolution	16 bits (-31276 to +31276)	15 bits (0 to +31276)	
	Maximum Allowable Load Current	±5 mA		
	Accuracy	25°C	±0.1% (±10 mV)	
		0°C to 55°C	±0.3% (±30 mV)	
Output Delay Time	1.2 ms*			
Motion Network	Two circuits for MECHATROLINK-III Transmission distance : 20 cm to 100 m		Transmission speed : 100 Mbps Terminator : not required	
External Power Supply	24 VDC (19.2 V to 28.8 V), 500 mA max.			

\*: After change with a full scale of -10 V to +10 V.

Note: Use a 24-VDC power supply and external input power supply with double or reinforced insulation.

### ● Pulse Input Module (MTP2900)



Model: JEPMC-MTP2900-E  
Approx. Mass: 300 g

Items	Specifications	
Pulse Input	Number of Channels	2
	Input Circuit (Selected by software)	5-V differential: 4-MHz response frequency (RS-422, not isolated) 12 V: 120-kHz response frequency (12 V, 7 mA, current source mode input, and photocoupler isolation)
	Input Method	A/B (1, 2, or 4 multipliers), UP/DOWN (1 or 2 multipliers), and sign (1 or 2 multipliers)
	Counter Functions	Reversible counter, interval counter, and frequency measurement
	Maximum Frequency	4 MHz with 5-V differential input (16 MHz with 4 multipliers)
	Coincident Output	2 points, 24 V, 50 mA current sink mode input, and photocoupler isolation
	DO Output	2 points, 24 V, 50 mA, current sink mode input, and photocoupler isolation (zone output, speed-coincidence output, and frequency-coincidence output)
	PI Latch Input	2 points, 24 V, source mode input, and photocoupler isolation
Input Method	Sign, UP/DOWN and A/B pulse	
Motion Network	Two circuits for MECHATROLINK-III      Transmission speed : 100 Mbps Transmission distance : 20 cm to 100 m      Terminator : not required	
External Power Supply	24 VDC (19.2 V to 28.8 V), 500 mA	

### ● Pulse Output Module (MTP2910)



Model: JEPMC-MTP2910-E  
Approx. Mass: 300 g

Items	Specifications	
Pulse Output	Number of Controlled Axes	4
	Pulse Output	Output Method : CW/CCW, sign + pulse, and phase A/B Maximum Frequency : 4 Mpps with CW/CCW or sign + pulse, 1 Mpps with phase A/B (before multiplication) Interface : 5-V differential outputs
	Digital Input	5 points × 4 channels, source mode input DI_0 : Separate for each power supply... 5 V/3.9 mA, 12 V/10.9 mA, 24 V/4.1 mA DI_1 to DI_4: Power supply shared ... 24 V/4.1 mA
	Digital Output	4 points × 4 channels    Open collector and sink mode output (24 V/100 mA)
Motion Network	Two circuits for MECHATROLINK-III      Transmission speed : 100 Mbps Transmission distance : 20 cm to 100 m      Terminator : not required	
External Power Supply	24 VDC (19.2 V to 28.8 V), 500 mA	

### ● Network Analyzer Module (MTNA-01)



Model: JEPMC-MT2010-E  
Approx. Mass: 270 g

Traces the data sent or received through MECHATROLINK-III communication (cyclic communication).

Items	Specifications
External Power Supply	Input supply voltage : 24 VDC ±20% Current consumption : 1 A max. Inrush current : 40 A max.
Motion Network	Two circuits for MECHATROLINK-III (To be connected to the end of network connection.) Transmission speed : 100 Mbps (MECHATROLINK-III) Transmission distance : 20 cm to 100 m Terminator : not required
Communication Ports	1 port (Ethernet : 100BASE-TX/10BASE-T)

Note : Requires the network analyzer tool (model : CMPC-NWAN710) for settings and operation.

## I/O Modules for MECHATROLINK-II

### ● 64-point I/O Modules (IO2310/IO2330)



Model: JEPMC-IO2310-E  
Approx. Mass: 590 g



Model: JEPMC-IO2330-E  
Approx. Mass: 590 g

Items	Specifications
I/O Signals	Input: 64 points, 24 VDC (20.4 V to 28.8 V), 5 mA, sink/source mode input Output: 64 points, 24 VDC (20.4 V to 28.8 V), 50 mA sink mode output (IO2310), source mode output (IO2330) Signal connection method: Connector (FCN360 series)
External Power Supply	24 VDC (20.4 V to 28.8 V) Rated current: 0.5 A, Inrush current: 1 A

### ● Various I/O Modules



Model: JEPMC-PL2900-E/PL2910-E,  
JEPMC-AN2900-E/AN2910-E  
Approx. Mass: 300 g



Model: JAMSC-IO2900-E/-IO2910-E,  
JAMSC-IO2920-E/-IO2950-E  
Approx. Mass: 300 g

#### Counter Module (PL2900)

Model	JEPMC-PL2900-E
Number of Input Channels	2
Functions	Pulse counter, notch output
Pulse Input Method	Sign (1/2 multipliers), A/B (1/2/4 multipliers), UP/DOWN (1/2 multipliers)
Max. Counter Speed	1200 kpps (4 multipliers)
Pulse Input Voltage	3/5/12/24 VDC
External Power Supply	For input signal: 24 VDC For driving load: 24 VDC For module: 24 VDC (20.4 V to 26.4 V) 150 mA max.

#### Pulse Output Module (PL2910)

Model	JEPMC-PL2910-E
Number of Output Channels	2
Functions	Pulse positioning, JOG run, zero-point return
Pulse Output Method	CW, CCW pulse, sign + pulse
Max. Output Speed	500 kpps
Pulse Output Voltage	5 VDC
Pulse Interface Circuit	Open collector output 5 VDC, 10 mA/circuit
External Control Signal	Digital input: 8 points/module 5 VDC × 4 points, 24 VDC × 4 points Digital output: 6 points/module 5 VDC × 4 points, 24 VDC × 2 points
External Power Supply	24 VDC (20.4 V to 26.4 V), 150 mA

#### Analog Input Module (AN2900)

#### Analog Output Module (AN2910)

Model	JEPMC-AN2900-E	JEPMC-AN2910-E
Number of Input/Output Channels	Input : 4	Output : 2
Input/Output Voltage Range	Input : -10 V to +10 V	Output : -10 V to +10 V
Input Impedance	1 MΩ min.	-
Max. Allowable Load Current	-	±5 mA (2 MΩ)
Data Region	-32000 to +32000	
Input/Output Delay Time	Input : 4 ms max.	Output : 1 ms max.
Error	+0.5% F.S (at 25°C), ±1.0% F.S (at 0°C to 60°C)	+0.2% F.S (at 25°C), ±0.5% F.S (at 0°C to 60°C)
External Power Supply	24 VDC (20.4 V to 26.4 V), 150 mA max.	24 VDC (20.4 V to 26.4 V), 180 mA max.

#### 16-point Input Module (IO2900)

#### 16-point Output Module (IO2910)

Model	JAMSC-IO2900-E	JAMSC-IO2910-E
Number of Input/Output Points	Input : 16	Output : 16
Rated Voltage	12/24 VDC	
Rated Current	2 mA/5 mA	0.3 A
Input/Output Method	Input : sink/source mode input	Output : sink mode output
External Power Supply	24 VDC (20.4 V to 26.4 V), 90 mA	24 VDC (20.4 V to 26.4 V), 110 mA

#### 8-point I/O Module (IO2920)

Model	JAMSC-IO2920-E
Number of I/O Points	Input : 8, Output : 8
Rated Voltage	12/24 VDC
Rated Current	Input : 2 mA/5 mA Output : 0.3 A
Input/Output Method	Input : sink/source mode input Output : sink mode output
External Power Supply	24 VDC (20.4 V to 26.4 V), 70 mA

#### Relay Output Module (IO2950)

Model	JAMSC-IO2950-E
Number of Output Points	8
Rated Voltage	12/24 VDC, 100/200 VAC
Rated Current	1.0 A
Output Method	Contact output
External Power Supply	24 VDC (20.4 V to 26.4 V), 90 mA



## ● HLS Master Module

Made by M-System Co., Ltd



Model: MPHLS-01  
Approx. Mass: 70g

Items	Specifications		
Transmission Protocol	Master and slave communications: polling		
	Full-duplex or half-duplex		
Connection Method	Multidrop connection (RS485)		
Transmission Speed	12Mbps	6Mbps	3Mbps
Transmission Distance	100m	200m	300m
Response Speed (with full-duplex)	4 stations	60.7 $\mu$ s	242.7 $\mu$ s
	8 stations	121.4 $\mu$ s	485.4 $\mu$ s
	16 stations	242.7 $\mu$ s	970.7 $\mu$ s
	32 stations	485.4 $\mu$ s	1.942ms
	63 stations	955.5 $\mu$ s	3.822ms
Number of Slaves	1 to 63		
Max Number of Slave Points	Discrete input: 1008; discrete output: 1008		
Communication Connector	RJ-45 modular jack		
Terminator	Built-in, 100 $\Omega$ terminator		

## ● A-net/A-Link Master Unit Module

Made by ALGO System Co., Ltd.



Model: MPANL00-0  
Approx. Mass: 90 g

Items	A-net	A-Link
Communication Control IC	MKY40	MKY36
Communication Mode	Two-wire half duplex	Four-wire full duplex / two-wire half duplex
Transmission Speed	3/6/12 Mbps	3/6/12 Mbps
Error Detection	CRC-16	CRC-12
Transmission Distance	300/200/100 m	300/200/100 m

## ● CUNet Master Module

Made by ALGO System Co., Ltd.



Model: MPCUNET-0  
Approx. Mass: 85 g

Items	Specifications
Communication Control IC	MKY40 $\times$ 1
Communication Mode	Two-wire, half-duplex (conforms to RS-485 specifications)
Isolation Method	Pulse transformer
Transmission Speed	3 Mbps, 6 Mbps, or 12 Mbps (recommended)
Synchronization Method	Bit synchronization
Error Detection	CRC-16
Max. Transmission Distance	12 Mbps: 100 m; 6 Mbps: 200 m; 3 Mbps: 300 m
Connection Method	Multidrop connection
Impedance	100 $\Omega$
Terminator	Enabled or disabled with the built-in switch.
External Interface	Euro-style, 6-pin terminal block

# Other Manufacturer Modules

## ● AnyWire DB Master Made by Anywire Corporation



Model: AFMP-01  
Approx. Mass: 90 g

Items	Specifications			
Transmission Clock	7.8 kHz	15.6 kHz	31.3 kHz	62.5 kHz
Max. Transmission Distance	1 km	500 m	200 m	100 m
Transmission Protocol	Special protocol (Anywire Bus DB protocol) Note: Upper compatibility with UNI-WIRE protocol			
Max. Number of I/Os	Full triple mode: 2304 points (Bit-Bus: 256 points, Word-Bus: 2048 points) Full quadruple mode: 2560 points (Bit-Bus: 512 points, Word-Bus: 2048 points)			
Dual-Bus Function	Bit-Bus	Full triple mode: 256 bits max., Full quadruple mode: 512 bits max.		
	Word-Bus	Full triple mode: 128 words max. (64 words each for IN and OUT), Full quadruple mode: 128 words max. (64 words each for IN and OUT)		
Max. Number of Stations	128 stations (Fan-out = 200) Note: Anywire DB products: Fan-in = 1, UNI-WIRE products: Fan-in = 10			
Connection Cable	General-purpose 2-wire cable or 4-wire cable (VCTF 0.75 sq to 1.25 sq) Special flat cable (0.75 sq), general purpose wire (0.75 sq to 1.25 sq)			

## ● CC-Link Interface Board Made by Anywire Corporation



Model: AFMP-02-C  
Approx. Mass: 90 g



Model: AFMP-02-CA  
Approx. Mass: 90 g

Items	Specifications	AFMP -02-C	AFMP -02-CA
CC-Link Specifications	Station Type	Remote device station	
	Number of Stations	4	
	No. of Remote Stations	Station number setting range: 1 to 61 (4 stations are occupied after setting the number of stations)	
	No. of Remote Device Points	Input: Max. 896 points, Output: Max. 896 points (Version 2.0 with 8 times setting) Input: Max. 112 points, Output: Max. 112 points (Version 1.1)	
	No. of Remote Register Points	Input: Max. 128 points, Output: Max. 128 points (Version 2.0 with 8 times setting) Input: Max. 16 points, Output: Max. 16 points (Version 1.1)	
	Transmission Speed	10 M, 5 M, 2.5 M, 625 k, and 156 kbps (Select with the switch.)	
	Transmission Distance	100 m (10 Mbps), 160 m (5 Mbps), 400 m (2.5 Mbps), 900 m (625 kbps), and 1200 m (156 kbps)	
	No. of CC-Link that can be connected	$(1 \times a) + (2 \times b) + (3 \times c) + (4 \times d) \leq 64$ [a: Number of slave products that occupy one station, b: Number of slave products that occupy two stations, c: Number of slave products that occupy three stations, d: Number of slave products that occupy four stations] $(16 \times A) + (54 \times B) + (88 \times C) \leq 2304$ [A: Number of remote I/O stations (Max. 64 units) B: Number of remote device station units (Max. 42 units) C: Number of local station and intelligent device station units (Max. 26 units)]	
Connection Cable	CC-Link cable; a three-core, shielded, twisted-pair cable		
Anywire DB Specifications	Transmission Clock	7.8 kHz, 15.6 kHz, 31.3 kHz, and 62.5 kHz	
	Max. Transmission Distance	Max. Overall Cable Extension Length: 100 m, 200 m, 500 m, or 1 km.	
	I/O Points	Full triplex mode: Max. 2304 points (Bit-bus: Max. 256 points, Word-bus: Max. 2048 points) Full quadruplex mode: 2560 points (Bit-bus: Max. 512 points, Word-bus: Max. 2048 points)	
	Anywire Bus Port	One port, detachable terminal block	
	Connection Cable	General-purpose 2-core or 4-core cable (VCTF 0.75 sq to 1.25 sq), dedicated flat cable (0.75 sq), general-purpose wire (0.75 sq to 1.25 sq)	

● Image-processing Unit (MYVIS)

A networked machine vision system that processes images and takes into account the servo coordinate system with detection of the servo-axis position.



Model: JEVSA-YV260  
Approx. Mass: 2.5 kg

Items		Standalone Type (Unit Type)	
		For Analog Cameras	For Camera Link
Model		JEVSA-YV260□1-E	JEVSA-YV260□2-E
Image Processing		Gray scale pattern matching, binary image analysis etc.	
CPU		Main CPU : SH-4A (600 MHz), Sub CPU : SH-2A (200 MHz)	
Image Processing Hardware	LSI	FPGA	
	Pre-processing Function	Inter-image operations (addition, averaging, subtraction, and difference operation), 3×3 filter, dilation/erosion	
Memory	Application Program	512 Kbytes (flash memory)	
	Backup Memory	256 Kbytes CMOS (for saving parameters)	
	Template Storage Memory	CF cards (2 Gbytes max.)	
	Image Memory	Frame Memory	4096×4096×8 bits×4 images (Can be used for 640×480×8 bits×192 images)
	Template Memory	16 Mbytes	
Image Input	Camera Interface	New EIAJ 12-pin connector × 4 VGA (640 × 480) to SXGA (1280 × 960) Four B&W, 8-bit A/D-converter circuits	CameraLink (MDR 26 pins) × 4 VGA (640×480) to QSXGA (2440×2048), Base Configuration, PoCL-compatible
	Camera Power Supply	Single camera : 12 V, 400 mA, Total : 1.2 A max.	
	Camera Sync Mode	Internal/external sync	Internal sync
	Random Shutter Supported	Sync-nonreset, sync-reset, single VD or V reset	
	Simultaneous Image Capture	Four cameras	
	Input Image Conversion	Gray level conversion (LUT), mirror mode	
Monitor	Monitor Output	VGA, XGA (color), 15pin D-sub	
	Image Display	A full-screen or a partial-screen for one camera, simultaneous screen reduction for two or four cameras, gray level conversion (binary image display supported)	
I/F	Field Network	MECHATROLINK-I / II	
	LAN (Ethernet)	10BASE-T/100BASE-TX	
	General-purpose Serial	RS-232C×2 channels (115.2 kbps)	
	Parallel I/O	16 general-purpose outputs (4 of these are also used for stroboscope) + 2 outputs exclusive for alarms (24 VDC, photocoupler isolation)	
		16 general-purpose inputs (4 of these are also used for trigger) + 3 inputs exclusive for mode switchings + 1 input exclusive for trigger (24 VDC, photocoupler isolation)	
Track Ball	USB mouse		
External Power Supply		100 V/200 VAC, 24 VDC, 30 W	

● MECHATROLINK-II Repeater

Required to stabilize communication and to extend the total length of the cable.



Model: JEPMC-REP2000  
Approx. Mass: 340 g

Items	Specifications
Communication Type	MECHATROLINK-II
Max. Cable Length	Between controller and repeater: 50 m, After repeater: 50 m
Max. Connected Stations	Total stations on both sides of repeater: 30*
Restrictions	<p>                     Total cable length ≤ 30 m: 15 stations max.                      30 m &lt; Total cable length ≤ 50 m: 14 stations max.                 </p> <p>                     Total cable length ≤ 30 m: 16 stations max.                      30 m &lt; Total cable length ≤ 50 m: 15 stations max.                 </p> <p>100 m max.</p>
External Power Supply	24 VDC (19.2 V to 28.8 V), 100 mA

\*: Limited to the max. number of connectable stations of the controller (e.g., 21 stations for the MP2000 series).

## MP3300

### ● Base Unit

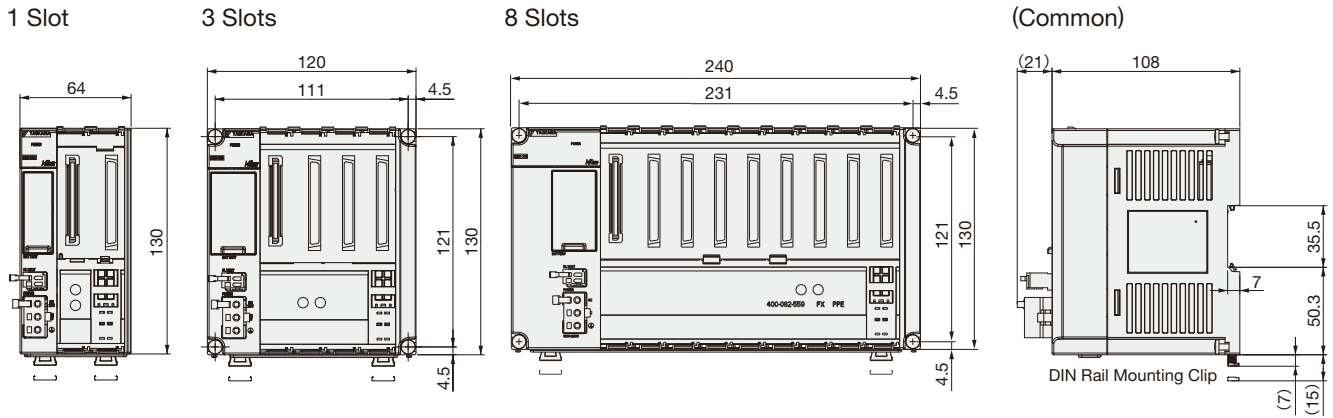

## MP2200 Base Units for Rack Expansion

### ● MBU-01, MBU-02

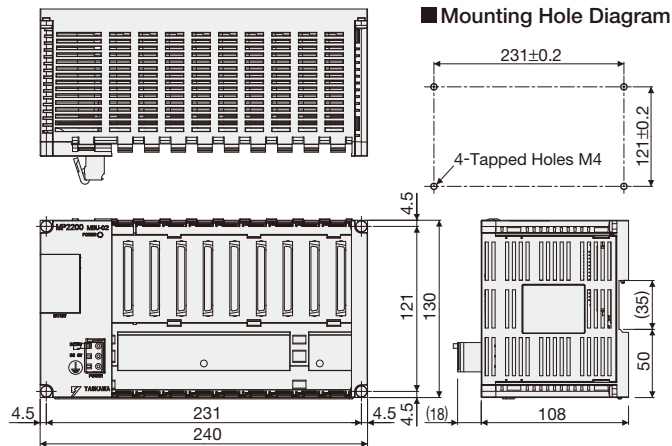

### ● MBU-03

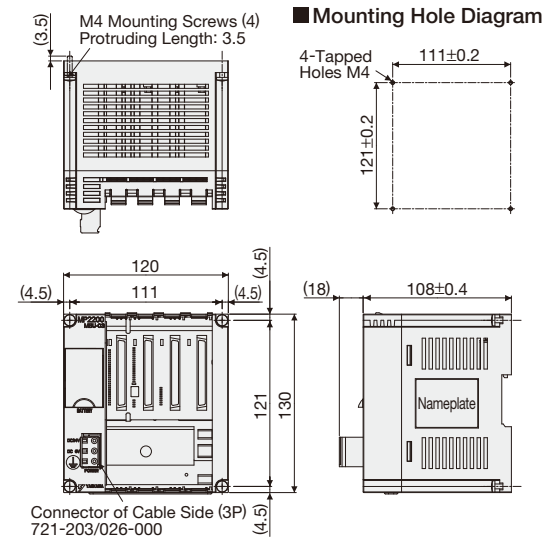

## Optional Modules (Common)

### ● MECHATROLINK-III Compatible Module

#### 64-point I/O Module

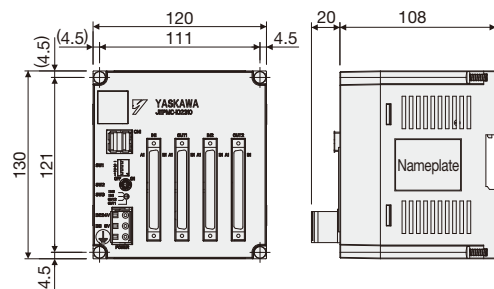

#### ■ Mounting Hole Diagram

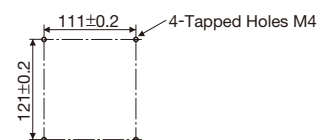

#### Hub Module

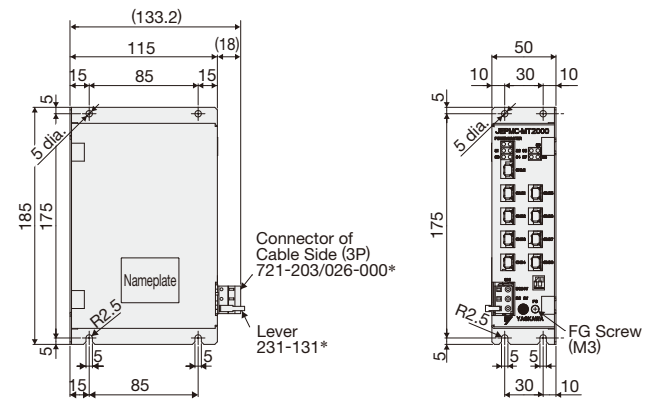

\*: Made by WAGO Company of Japan, Ltd.

**Analog Input Module**

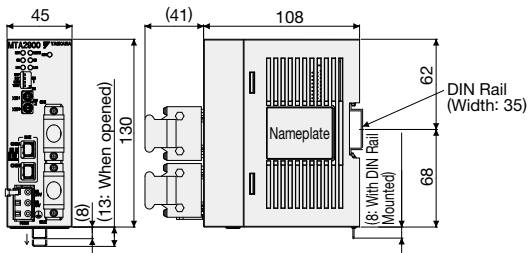

**Analog Output Module**

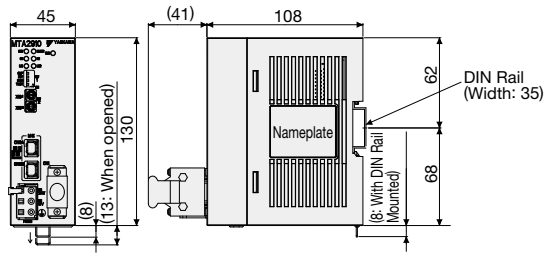

**Pulse Input Module**

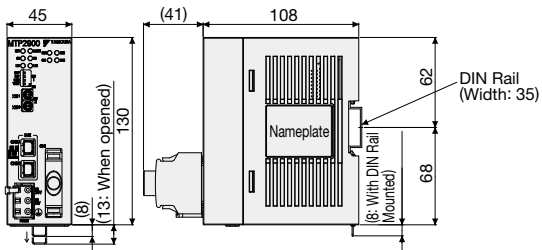

**Pulse Output Module**

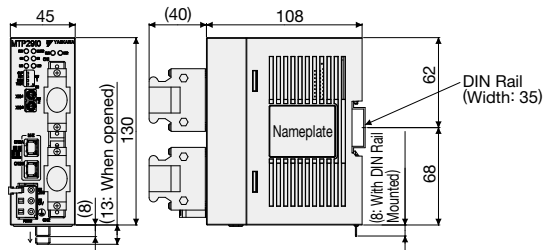

**Gateway Module**

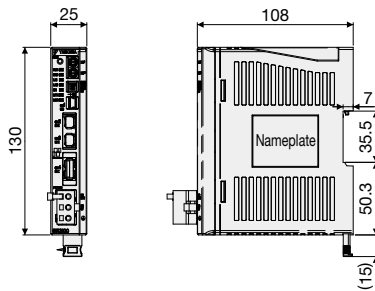

**Network Analyzer Module**

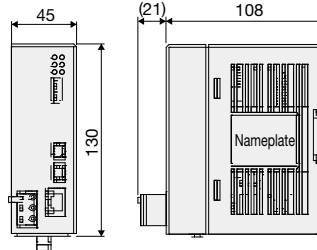

**MECHATROLINK-II Compatible Module**

**64-point I/O Module**

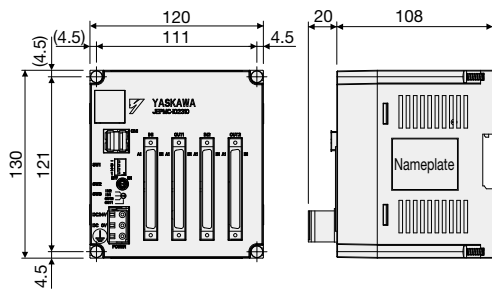

**Mounting Hole Diagram**

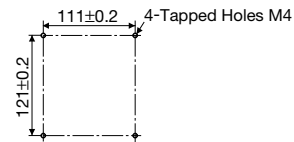

**Counter, Pulse, and Analog Modules**

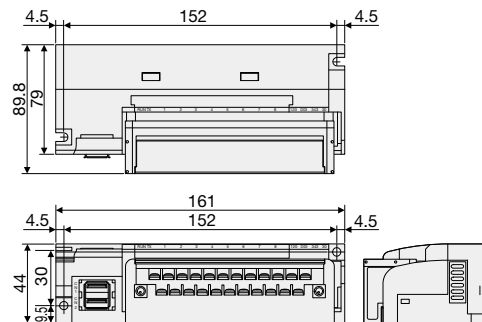

**Mounting Hole Diagram (Two Methods)**

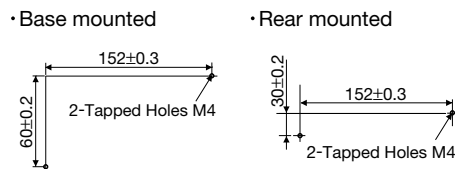

**16-point/8-point I/O Module, Relay Output Module**

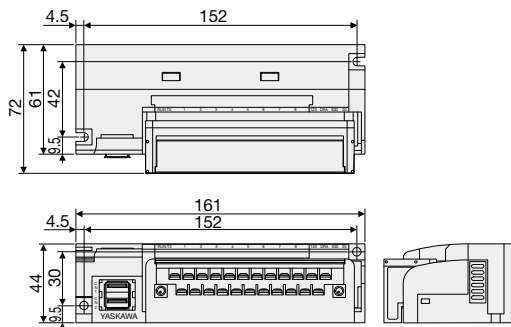

## ● Sequence Controls

Items	Specifications
Program Capacity	15 MB CPU-301/-302 (16 axes) 31 MB CPU-301/-302 (32 axes)
Control Method	Sequence: High-speed and low-speed scan methods
Programming Language	Ladder language: Relay circuit    Textual language: Numerical operations, logic operations, etc.
Scanning	2 scan levels : High-speed scan and low-speed scan High-speed scan time setting: 0.250 ms to 32 ms (Integral multiple of a MECHATROLINK communication cycle) CPU-301 0.125 ms to 32 ms (Integral multiple of a MECHATROLINK communication cycle) CPU-302 Low-speed scan time setting : 2.0 ms to 300 ms (Integral multiple of a MECHATROLINK communication cycle)
User Drawings, Functions, and Motion Programs	Startup drawings (DWG.A) : 64 drawings max. Up to 3 hierarchical drawing levels High-speed scan process drawings (DWG.H): 1000 drawings max. Up to 3 hierarchical drawing levels Low-speed scan process drawings (DWG.L) : 2000 drawings max. Up to 3 hierarchical drawing levels Interrupt processing drawings (DWG.I) : 64 drawings max. Up to 3 hierarchical drawing levels Number of steps : Up to 4000 steps/drawing User functions : Up to 2000 functions Motion programs : Up to 512 Revision history of drawings and motion programs Security functions of drawings and motion programs
Data Memory	System (S) registers : 64 K words Common data (M) registers : 1 M words (battery backup) Common global registers (G) : 2 M words (no battery backup) Drawing local (D) registers : 16 K words Drawing constant (#) registers : 16 K words Input (I) registers : 64 K words (shared with output registers) Output (O) registers : 64 K words (shared with input registers) Constant (C) registers : 16 K words
Trace Memory	Data trace : 256 K words/4 groups, 16 items/group defined; CPU-301/-302 (16 axes) : 1 M words/4 groups, 16 items/group defined; CPU-301/-302 (32 axes)
Memory Backup	Program memory : Flash memory (Battery backup for M registers)
Data Types	Bit (B) : 0.1 Integer (W) : -32,768 to +32,767 Double-length integer (L) : -2,147,483,648 to +2,147,483,647 Quadruple-length integer (Q) : -9,223,372,036,854,775,808 to 9,223,372,036,854,775,807 single-precision real number (F) : ± (1.175E-38 to 3.402E+38), 0 Double-precision real number (D): ± (2.225E-308 to 1.798E+308), 0 Address : 0 to 16777214
Register Designation Method	Register number : Direct designation of register number Symbolic designation: Up to 8 alphanumeric characters (up to 200 symbols/drawing) With automatic number or symbol assignment

## ● Motion Controls

Items	Specifications	
Control Specifications	PTP control, interpolation, speed reference output, torque reference output, position reference output, phase reference output	
Zero-point Return (17 types)	① DEC1+C                      ② ZERO                      ③ DEC1+ZERO                      ④ C pulse ⑤ DEC2+ZERO                      ⑥ DEC1+LMT+ZERO                      ⑦ DEC2+C                      ⑧ DEC1+LMT+C ⑨ C pulse only                      ⑩ POT & C pulse                      ⑪ POT only                      ⑫ HOME LS & C ⑬ INPUT                      ⑭ HOME only                      ⑮ NOT & C pulse                      ⑯ NOT only ⑰ INPUT & C pulse Note: Types ⑤ to ⑯ are available only with SVA.	
Number of Controlled Axes	1 to 32 axes (1 group)	
Reference Unit	mm, inch, deg, pulse	
Reference Unit Minimum Setting	1, 0.1, 0.01, 0.001, 0.0001, 0.00001	
Coordinate System	Rectangular coordinates	
Max. Programmable Value	-9,223,372,036,854,775,808 to 9,223,372,036,854,775,807 (signed 64-bit value)	
Speed Reference Unit	mm/min, inch/min, deg/min, pulse/min, mm/s, inch/s, deg/s, pulse/s	
Acceleration/Deceleration Type	Linear, asymmetric, S-curve	
Override Function	Positioning : 0.01% to 327.67% by axis Interpolation: 0.01% to 327.67% by group	
Programs	Language	Motion language, ladder language
	Number of Tasks	32 (Equal to the number of tasks that the ladder instruction, MSEE, can execute at the same time.)
	Number of Programs	Up to 512

## ● Hardware and Software Requirements

Item	Specifications
CPU	1 GHz or more recommended (manufactured by Intel or other companies)
Memory Capacity	1 Gbytes or more recommended*
Free Hard Disk Space	700 Mbytes or more (includes standard workspace memory after installation of MPE720)
Display	1280 × 800 pixels or more recommended
CD Drive	1 (only for installation)
Communication Port	RS-232C, Ethernet, MP2100 bus, or USB
OS	Windows 10, Windows 8, Windows 8.1, Windows 7 (32-bit, 64-bit)
.NET Environment	.NET Framework 4.5
Languages Supported	English, Japanese
Applicable Model	MP3000 and MP2000 series

\*: Expand memory if other application programs are run simultaneously with MPE720 on the same computer.  
Performance may be slow due to the use of memory by multiple application programs that are run simultaneously.

## ● Functions

Item	Specifications
Programming	Ladder programs (ladder language) Motion programs (motion language) Text format programming (position teaching)
Variables, Comments	Variable database management System and user variables, axis variables, input/output variables, global variables, system and user structures
Search, Replace	Cross-reference searches, instruction searches, character string and comment searches Register replacement, character string and comment replacement
Monitor	Register lists Watch Adjustment panel Axis operation monitor Axis alarm monitor Operation control panel
Tracing	Real-time tracing X-Y tracing Trace manager Data logging
MC-Configurator	Module configuration definitions (unit, module, slave allocation) Module detail definitions (system settings, communication settings, etc.) Parameter editing (fixed, setting, monitor, servo, distributed I/O, etc.) Servo adjustments (setup, test operation, tuning) Inverter adjustments (setup) Vision adjustments
Security Functions	Project file security Program security (ladder programs, motion programs) On-line security (access limited to users with specific levels of authority) User management
Servicing and Maintenance	Status list Maintenance monitor setting function
Project Conversion	Conversion of MP2000 project into MP3000 project
System	Language switching (between Japanese and English)
Remote Engineering	Modem connection RAS server connection
Electronic Cam Tool	Electronic cam data generation
Help	On-line manual help (help for instructions, operations) Version information
Printing	Preview Program Cross reference
Customized Functions	Editor Toolbar

## ● Instructions for Motion Programs

☐ : New instructions for MP3000 series

Type	Instruction	Function
Axis Setting Instructions	ABS	Absolute Mode
	INC	Incremental Mode
	ACC	Change Acceleration Time
	DCC	Change Deceleration Time
	SCC	Change S-curve Time Constant
	VEL	Set Speed
	FUT	Select Interpolation Feed Speed Units
	FMX	Set Maximum Interpolation Feed Speed
	IFP	Set Interpolation Feed Speed Ratio
	IUT	Select Interpolation Accel/decel Units
	IFMX	Set Maximum Interpolation Feed Speed per axis
	IAC	Change Interpolation Acceleration Time
	IDC	Change Interpolation Deceleration Time
	IDH	Change Interpolation Deceleration Time for Temporary Stop
ACCMODE	Set Interpolation Acceleration/Deceleration Mode	
Axis Movement Instructions	MOV	Positioning
	MVS	Linear Interpolation
	MCW	Clockwise: Circular Interpolation, Helical Interpolation
	MCC	Counterclockwise: Circular Interpolation, Helical Interpolation
	ZRN	Zero Point Return
	DEN	Position after Distribution
	SKP	Skip Function
	MVT	Set-time Positioning
	EXM	External Positioning
Axis Control Instructions	POS	Set Current Position
	MVM	Move on Machine Coordinates
	PLD	Update Program Current Position
	PFN	In-Position Check
	INP	In-Position Range
	PFP	Positioning Completed Check
	PLN	Coordinate Plane Setting
Vision Instructions	VCAPI	Image Capture
	VCAPS	Image Capture (With External Trigger Signal Sync)
	VFIL	Pre-Processing
	VANA	Image Analysis
	VRES	Analysis Acquisition

Type	Instruction	Function	
Program Control Instructions	IF, ELSE, IEND	Branching	
	WHILE, WEND	Repetition	
	WHILE, WENDX	Repetition with One Scan Wait	
	PFORK, JOINTO, PJOINT	Parallel Execution	
	SFORK, JOINTO, SJOINT	Selective Execution	
	MSEE	Call Subprogram	
	UFC	User Function	
	END	Program End	
	RET	Subprogram Return	
	TIM	Dwell Time (10 ms)	
	TIM1MS	Dwell Time (1 ms)	
	IOW	I/O Variable Wait	
	EOX	One Scan Wait	
	SNGD, SNGE	Disable Single-block Signal (SNGD) and Enable Single-block Signal (SNGE)	
	Other Control Instructions	=	Substitution
		+, -, *, /, MOD	Numeric operations
++		Extended Add	
--		Extended Subtract	
, ^, &, !		Logic operations	
SIN, COS, TAN, ASN, ACS, ATAN, SQRT, BIN, BCD		Basic functions	
=, <, >, <=, >=		Numeric comparison	
SFR, SFL, BLK, CLR, ASCII		Data manipulation	
SETW		Table Initialization	
() , S{ } , R{ }		Others	

## ● Instructions for Sequence Programs

Type	Instruction	Function
Control Instructions	SSEE	Sequence program call
	FUNC	User function call
Sequence Control Instructions	PON	Rising pulse
	NON	Falling pulse
	TON	Turn On Delay timer (10 ms)
	TON1MS	Turn On Delay timer (1 ms)
	TOF	Turn OFF Delay timer (10 ms)
	TOF1MS	Turn OFF Delay timer (1 ms)



## ● Instructions for Ladder Programs

□ : New instructions for MP3000 series

Type	Instruction	Function	Type	Instruction	Function
Relay Circuit Instructions	NOC	NO Contact	Logic Operation Instructions	AND	AND
	ONP-NOC	Rising-edge NO Contact		OR	Inclusive OR
	OFFP-NOC	Falling-edge NO Contact		XOR	Exclusive OR
	NCC	NC Contact		<	Less Than
	ONP-NCC	Rising-edge NC Contact		≤	Less Than or Equal
	OFFP-NCC	Falling-edge NC Contact		=	Equal
	TON (1 ms)	1-ms ON-Delay Timer		≠	Not Equal
	TOFF (1 ms)	1-ms OFF-Delay Timer		≥	Greater Than or Equal
	TON (10 ms)	10-ms ON-Delay Timer		>	Greater Than
	TOFF (10 ms)	10-ms OFF-Delay Timer		RCHK	Range Check
	TON (1 s)	1-s ON-Delay Timer	Program Control Instructions	SEE	Call Sequence Subprogram
	TOFF (1 s)	1-s OFF-Delay Timer		MSEE	Call Motion Program
	ON-PLS	Rising-edge Pulses		FUNC	Call User Function
	OFF-PLS	Falling-edge Pulses		INS	Direct Input String
	COIL	Coil		OUTS	Direct Output String
	REV-COIL	Reverse Coil		XCALL	Call Extended Program
	ONP-COIL	Rising-edge Detection Coil		WHILE END_WHILE	WHILE construct
	OFFP-COIL	Falling-edge Detection Coil		FOR END_FOR	FOR construct
	S-COIL	Set Coil		IF END_IF	IF construct
	R-COIL	Reset Coil		IF ELSE END_IF	IF-ELSE construct
Numeric Operation Instructions	STORE	Store	Basic Function Instructions	EXPRESSION	Numerical expressions
	ADD (+)	Add		SQRT	Square Root
	ADDX (++)	Extended Add		SIN	Sine
	SUB (-)	Subtract		COS	Cosine
	SUBX (--)	Extended Subtract		TAN	Tangent
	MUL (×)	Multiply		ASIN	Arc Sine
	DIV (÷)	Divide		ACOS	Arc Cosine
	MOD	Integer Remainder		ATAN	Arc Tangent
	REM	Real Remainder		EXP	Exponential
	INC	Increment		LN	Natural Logarithm
	DEC	Decrement	LOG	Common Logarithm	
	TMADD	Add Time			
	TMSUB	Subtract Time			
	SPEND	Spend Time			
	INV	Invert Sign			
	COM	One's Complement			
	ABS	Absolute Value			
	BIN	Binary Conversion			
	BCD	BCD Conversion			
	PARITY	Parity Conversion			
	ASCII	ASCII Conversion 1			
	BINASC	ASCII Conversion 2			
	ASCBIN	ASCII Conversion 3			

## ● Instructions for Ladder Programs (Cont'd)

□ : New instructions for MP3000 series

Type	Instruction	Function
Data Manipulation Instructions	ROTL	Bit Rotate Left
	ROTR	Bit Rotate Right
	MOVB	Move Bit
	MOVW	Move Word
	XCHG	Exchange
	SETW	Table Initialization
	BEXTD	Byte-to-word Expansion
	BPRESS	Word-to-byte Compression
	BSRCH	Binary Search
	SORT	Sort
	SHFTL	Bit Shift Left
	SHFTR	Bit Shift Right
	COPYW	Copy Word
BSWAP	Byte Swap	
DDC Instructions	DZA	Dead Zone A
	DZB	Dead Zone B
	LIMIT	Upper/Lower Limit
	PI	PI Control
	PD	PD Control
	PID	PID Control
	LAG	First-order Lag
	LLAG	Phase Lead Lag
	FGN	Function Generator
	IFGN	Inverse Function Generator
	LAU	Linear Accelerator/Decelerator 1
	SLAU	Linear Accelerator/Decelerator 2
	PWM	Pulse Width Modulation

Type	Instruction	Function
Table Manipulation Instructions	TBLBR	Read Table Block
	TBLBW	Write Table Block
	TBLSRL	Search Table Row
	TBLSRC	Search Table Column
	TBLCL	Clear Table Block
	TBLMV	Move Table Block
	QTBLR	Read Queue Table
	QTBLRI	Read Queue Table with Pointer Increment
	QTBLW	Write Queue Table
	QTBLWI	Write Queue Table with Pointer Increment
QTBLCL	Clear Queue Table Pointer	
Standard System Function Instructions	COUNTER	Counter
	FINFOUT	First-in First-out
	FLASH-OP	Flash memory operation
	TRACE	Trace
	DTRC-RD/DTRC-RDE	Read Data Trace
	ITRC-RD	Inverter trace read
	MSG-SND	Send Message
	MSG-SNDE	Send Message (Extension)
	MSG-RCV	Receive Message
	MSG-RCVE	Receive Message (Extension)
	ICNS-WR	Inverter constant write
	ICNS-RD	Inverter constant read
	MLNK-SVW	SERVOPACK constant write
	MLNK-SVR	SERVOPACK constant read
	MOTREG-W	Motion register write
	MOTREG-R	Motion register read
IMPORT/IMPORTL/ IMPORTLE	Import	
EXPORT/EXPORTL/ EXPORTLE	Export	

## ● EXPRESSION instructions

□ : New instructions for MP3000 series

Type	Symbol	Function	Type	Symbol	Function
Arithmetic Operators	+	Addition	Basic Function Instructions	SQRT	Square root instructions
	++	Extended Add		SQRT_W SQRT_F SQRT_D	
	-	Subtraction		SIN	
	--	Extended Subtract		SIN_W SIN_F SIN_D	
	*	Multiplication		COS	Cosine instructions (real number operations)
	/	Division		COS_W COS_F COS_D	
	&	AND instruction (bit operation)		TAN	
	Logical Operators			OR instruction (bit operation)	ASIN
^		Exclusive OR instruction (bit operation)		ASIN_W ASIN_F ASIN_D	
&&		AND instruction		ACOS	Arc cosine instruction
Comparison Operators		OR instruction		ATAN	Arc tangent instructions (real number operation)
	!	Logical NOT instruction		ATAN_W ATAN_F ATAN_D	
	<	Less than		ABS	
	<=	Less than or equal		EXP	Exponential instruction
	=	Equal		LN	Natural logarithm instruction
	!=	Not equal		LOG	Common logarithm instruction
Assignment Operator	>=	Greater than or equal		(WORD)	word
	>	Greater than		(LONG)	long
	=	Store instruction		(QUAD)	quad
				(FLOAT)	float
Program Control Instructions	FOR <variable> = <initial value> TO <final value> STEP <step value> ... FEND	Fixed count repetition control	(DOUBLE)	double	
	WHILE <conditional expression> ... WEND	Pre-tested repetition control	FTYPE	Float-type operation specification	
	IF<conditional expression> ... IEND	Conditional branching 1	DTYPE	Double-type operation specification	
	IF<conditional expression> ... ELSE ... IEND	Conditional branching 2			
Cast Operators					

## ● Electronic Cam Data Generation Tool

Items	Specifications
Data Generation	<p>Cam curves can be selected from:</p> <ul style="list-style-type: none"> <li>· Straight line</li> <li>· Cycloid</li> <li>· Modified constant velocity</li> <li>· Trapezoid</li> <li>· Single-dwell modified trapezoid m=1</li> <li>· Single-dwell modified sine</li> <li>· No-dwell modified trapezoid</li> <li>· Free-form curve</li> <li>· Inverted paired strings</li> <li>· Parabolic</li> <li>· Modified trapezoid</li> <li>· Asymmetrical cycloid</li> <li>· Single-dwell cycloid m=1</li> <li>· Single-dwell ferguson trapezoid</li> <li>· Single-dwell trapezoid</li> <li>· No-dwell modified constant velocity</li> <li>· Inverted trapezoid</li> <li>· Simple harmonic</li> <li>· Modified sine</li> <li>· Asymmetrical modified trapezoid</li> <li>· Single-dwell cycloid m=2/3</li> <li>· Single-dwell modified trapezoid m=2/3</li> <li>· No-dwell simple harmonic</li> <li>· NC2 curve</li> <li>· Paired strings</li> </ul>
Data Editing	<p>Data graph: Parameter setting, style setting, graph data editing</p> <p>Data list: Insert, delete, etc.</p> <p>Control graph display: Displacement data, speed data, acceleration data, jerk data, graph comparison</p>
Data Transfer	Cam data file is transferred to registers (M or C)

## ● MP3300

Classifications	Products	Model Name	Model	Specifications	Qty
MP3300	CPU module	CPU-301 (16 axes)	JAPMC-CP3301-1-E	High-speed scan time setting: Min. 250 $\mu$ s Communications cycle*: Min. 250 $\mu$ s Program capacity: 15 MB Battery (JZSP-BA01) for backup data is included.	
		CPU-301 (32 axes)	JAPMC-CP3301-2-E	High-speed scan time setting: Min. 250 $\mu$ s Communications cycle*: Min. 250 $\mu$ s Program capacity: 31 MB Battery (JZSP-BA01) for backup data is included.	
		CPU-302 (16 axes)	JAPMC-CP3302-1-E	High-speed scan time setting: Min. 125 $\mu$ s Communications cycle*: Min. 125 $\mu$ s Program capacity: 15 MB Battery (JZSP-BA01) for backup data is included.	
		CPU-302 (32 axes)	JAPMC-CP3302-2-E	High-speed scan time setting: Min. 125 $\mu$ s Communications cycle*: Min. 125 $\mu$ s Program capacity: 31MB Battery (JZSP-BA01) for backup data is included.	
	Base unit	MBU-301	JEPMC-BU3301-E	100/200 VAC input base unit (8 slots)	
		MBU-302	JEPMC-BU3302-E	24 VDC input base unit (8 slots)	
		MBU-303	JEPMC-BU3303-E	24 VDC input base unit (3 slots)	
		MBU-304	JEPMC-BU3304-E	24 VDC input base unit (1 slot)	
	MP2200 base unit	MBU-01	JEPMC-BU2200-E	100 VAC/200 VAC input base unit (9 slots)	
		MBU-02	JEPMC-BU2210-E	24 VDC input base unit (9 slots)	
		MBU-03	JEPMC-BU2220-E	24 VDC input base unit (4 slots)	

\* : The cycle in which the host controller creates and sends references.

## ● Optional Modules for MP3000 and MP2000 Series

Classifications	Products	Model Name	Model	Specifications	Qty
CPU Module	Multiple-CPU module	MPU-01	JAPMC-CP2700-E	Module with CPU and SVC-01 functions, 1 channel for MECHATROLINK-III	
Connection Module	Expansion interface module	EXIOIF*1	JAPMC-EX2200-E	Expansion interface	
Motion Modules	Motion module	SVC-01	JAPMC-MC2320-E	1 channel for MECHATROLINK-III	
		SVB-01	JAPMC-MC2310-E	1 channel for MECHATROLINK-II	
	Analog motion module	SVA-01	JAPMC-MC2300-E	Analog-output 2-axis servo control	
	Pulse output motion module	PO-01	JAPMC-PL2310-E	Pulse-output, 4-axis servo control	
Communication Modules	General-purpose serial communication module	217IF-01	JAPMC-CM2310-E	RS-232C/RS-422 communication	
	Ethernet communication module	218IF-01	JAPMC-CM2300-E	RS-232C/Ethernet communication	
		218IF-02	JAPMC-CM2302-E	RS-232C/Ethernet (100 Mbps) communications	
	DeviceNet communication module	260IF-01	JAPMC-CM2320-E	RS-232C/DeviceNet communication	
	PROFIBUS communication module	261IF-01	JAPMC-CM2330-E	RS-232C/PROFIBUS communication	
	FL-net communication module	262IF-01	JAPMC-CM2303-E	Cyclic transmission and message transmission	
	EtherNet / IP communication module	263IF-01	JAPMC-CM2304-E	I/O transmission and Explicit message transmission	
	EtherCAT communication module	264IF-01	JAPMC-CM2305-E	As a slave station of EtherCAT	
	CompoNet communication module	265IF-01	JAPMC-CM2390-E	CompoNet communication	
	PROFINET communication module	266IF-01*2	JAPMC-CM2306-E	PROFINET master	
		266IF-02	JAPMC-CM2307-E	PROFINET slave	
	CC-Link IE Field Slave Module	269IF-01	JAPMC-CM2308-E	CC-Link IE Field slave	
MPLINK communication module	215AIF-01 MPLINK	JAPMC-CM2360-E	RS-232C/MPLINK communication		
CP-215 communication module	215AIF-01 CP-215	JAPMC-CM2361	RS-232C/CP-215 communication		

\*1: Connect the Expansion Interface Module to the MP2200 Base Unit for Rack Expansion.

\*2: Estimates are required before ordering this product. Contact your Yaskawa representative for more information.

(Cont'd)

## ● Optional Modules for MP3000 and MP2000 Series (Cont'd)

Classifications	Products	Model Name	Model	Specifications	Qty
I/O Modules	I/O module	LIO-01	JAPMC-IO2300-E	16-point input, 16-point output (sink mode output), pulse input: 1 channel	
		LIO-02	JAPMC-IO2301-E	16-point input, 16-point output (source mode output), pulse input: 1 channel	
		LIO-04	JAPMC-IO2303-E	32-point input and 32-point output (sink mode output)	
		LIO-05	JAPMC-IO2304-E	32-point input and 32-point output (source mode output)	
		LIO-06	JAPMC-IO2305-E	Digital input: 8 points, digital output: 8 points, analog input: 1 channel, analog output: 1 channel, pulse counter: 1 channel	
	Output module	DO-01	JAPMC-DO2300-E	64-point output (sink mode output)	
	Analog input module	AI-01	JAPMC-AN2300-E	8 channels for analog input	
	Analog output module	AO-01	JAPMC-AN2310-E	4 channels for analog output	
Counter module	CNTR-01	JAPMC-PL2300-E	2 channels, selection of 2 input circuits: 5-V differential or 12 V.		
MECHATROLINK-III Compatible Modules	Hub module	HUB	JEPMC-MT2000-E	–	
	MECHATROLINK compatible gateway module	GW3100	JEPMC-GW3100-E	MECHATROLINK-III×2 MECHATROLINK-II×1	
	64-point I/O module	MTD2310	JEPMC-MTD2310-E	64-point input and 64-point output (sink mode output)	
	Analog input module	MTA2900	JEPMC-MTA2900-E	Analog input: 8 channels	
	Analog output module	MTA2910	JEPMC-MTA2910-E	Analog output: 4 channels	
	Pulse input module	MTP2900	JEPMC-MTP2900-E	Pulse input: 2 channels	
	Pulse output module	MTP2910	JEPMC-MTP2910-E	Pulse output: 4 channels	
	Network analyzer module	MTNA-01	JEPMC-MT2010-E	–	
MECHATROLINK-II Compatible Modules	64-point I/O module	IO2310	JEPMC-IO2310-E	64-point input and 64-point output (sink mode output)	
		IO2330	JEPMC-IO2330-E	64-point input and 64-point output (source mode output)	
	Counter module	PL2900	JEPMC-PL2900-E	Reversible counter: 2 channels	
	Pulse output module	PL2910	JEPMC-PL2910-E	Pulse output: 2 channels	
	Analog input module	AN2900	JEPMC-AN2900-E	Analog input: –10 V to +10 V, 4 channels	
	Analog output module	AN2910	JEPMC-AN2910-E	Analog output: –10 V to +10 V, 2 channels	
	16-point input module	IO2900	JAMSC-IO2900-E	16-point input	
	16-point output module	IO2910	JAMSC-IO2910-E	16-point output (sink mode output)	
	8-point I/O module	IO2920	JAMSC-IO2920-E	8-point input and 8-point output (sink mode output)	
Relay output module	IO2950	JAMSC-IO2950-E	8 contact outputs		

## ● Support Tool







Classifications	Products	Model Name	Model	Specifications	Qty
Engineering Tool	MPE720 Version 7	–	CPMC-MPE780D	Engineering tool for MP3000 series controller OS: Windows 10/8/8.1/7	

## ● Cables and Connectors

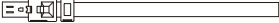
Name	Model	Length m	Specifications	Qty
MECHATROLINK-III Cable	JEPMC-W6012-A2-E	0.2	With MECHATROLINK-III connectors on both ends	
	JEPMC-W6012-A5-E	0.5		
	JEPMC-W6012-01-E	1.0		
	JEPMC-W6012-02-E	2.0		
	JEPMC-W6012-03-E	3.0		
	JEPMC-W6012-05-E	5.0		
	JEPMC-W6012-10-E	10.0		
	JEPMC-W6012-20-E	20.0		
	JEPMC-W6012-30-E	30.0		
	JEPMC-W6012-50-E	50.0		
	JEPMC-W6013-10-E	10.0		With ferrite core
	JEPMC-W6013-20-E	20.0		
	JEPMC-W6013-30-E	30.0		
	JEPMC-W6013-50-E	50.0		
	JEPMC-W6013-75-E	75.0		



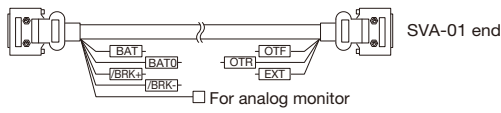
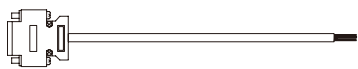



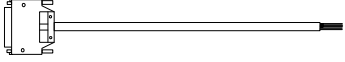

(Cont'd)

## ● Cables and Connectors (Cont'd)

Name	Model	Length m	Specifications	Qty	
MECHATROLINK-III Cable (Cont'd)	JEPMC-W6014-A5-E	0.5	With a connector on the controllers end 		
	JEPMC-W6014-01-E	1.0			
	JEPMC-W6014-03-E	3.0			
	JEPMC-W6014-05-E	5.0			
	JEPMC-W6014-10-E	10.0			
	JEPMC-W6014-30-E	30.0			
	JEPMC-W6014-50-E	50.0			
Cable for MECHATROLINK-II and MPLINK	JEPMC-W6002-A5-E	0.5	With connectors on both ends 		
	JEPMC-W6002-01-E	1.0			
	JEPMC-W6002-03-E	3.0			
	JEPMC-W6002-05-E	5.0			
	JEPMC-W6002-10-E	10.0			
	JEPMC-W6002-20-E	20.0			
	JEPMC-W6002-30-E	30.0			
	JEPMC-W6002-40-E	40.0			
	JEPMC-W6002-50-E	50.0			
	JEPMC-W6003-A5-E	0.5		With ferrite core 	
	JEPMC-W6003-01-E	1.0			
	JEPMC-W6003-03-E	3.0			
	JEPMC-W6003-05-E	5.0			
	JEPMC-W6003-10-E	10.0			
	JEPMC-W6003-20-E	20.0			
	JEPMC-W6003-30-E	30.0			
	JEPMC-W6003-40-E	40.0			
JEPMC-W6003-50-E	50.0				
Terminator	JEPMC-W6022-E	-	For MECHATROLINK-II 		
Ferrite Core	JEPMC-W6021	-	For MECHATROLINK-II cable 		
Connection Cable for SVA-01	JEPMC-W2040-A5-E	0.5	With connectors on both ends 		
	JEPMC-W2040-01-E	1.0			
	JEPMC-W2040-03-E	3.0			
	JEPMC-W2041-A5-E	0.5	With a connector on the controller end 		
	JEPMC-W2041-01-E	1.0			
	JEPMC-W2041-03-E	3.0			
RS-232C Communication Cable (217IF-01, 218IF-01, 260IF-01, 261IF-01, and 215AIF-01)	JEPMC-W5311-03-E	2.5	Connection cable for MPE720-installed PC  PC side: D-sub, 9-pin, and female Communication module side: D-sub, 9-pin, and male		
	JEPMC-W5311-15-E	15.0			
RS-422/485 Communication Cable for 217IF-01	No ready-made cable available. Prepare a cable that meets these specifications. : Connector: 10114-3000PE made by 3M Japan Ltd. Shell : 10314-52A0-008 made by 3M Japan Ltd. Cable : Max. length 300 m, shielded (Use shielded CAT cable and a modem to reduce noise.)				
Ethernet Communication Cable for 218IF-01	Use 10Base-T cross or straight cables.				
Ethernet Communication Cable for 218IF-02	Use 100Base-TX cross or straight cables.				
DeviceNet Communication Cable for 260IF-01	Use DeviceNet cables. Refer to the ODVA web site. ( <a href="http://www.odva.org/">http://www.odva.org/</a> )				

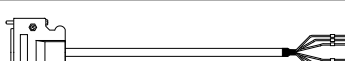
(Cont'd)

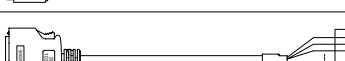
## ● Cables and Connectors (Cont'd)

Name	Model	Length m	Specifications	Qty
PROFIBUS Communication Cable for 2611F-01	Use PROFIBUS cables. Refer to the PROFIBUS web site ( <a href="http://www.profibus.jp/">http://www.profibus.jp/</a> ). Make sure the cable outlet position and direction so that it will not stand in the way of the RS-232C connector connection when selecting a cable.			
CC-Link IE Field Communication Cable for 2691F-01	No ready-made cable available. Prepare a recommended cable for CC-Link IE Field.: Cable: IEEE802.3 1000BASE-T standard cable We recommend a flat 4-pair double-shielded cable that conforms with ANSI/TIA/EIA-568-B (Category 5e). Connector: Shielded RJ-45			
CP-215 Communication Cable for 215AIF-01	No ready-made cable available. Prepare a cable that meets these specifications.: Wire: YS-IPEV-SB (75Ω) or YS-IPEV-S (77Ω) made by Fujikura Ltd. Connector on module end: MR-8RFA4 (G) made by Honda Tsushin Kogyo, Co., Ltd. Connector on cable end: MR-8M (G) made by Honda Tsushin Kogyo, Co., Ltd.			
I/O Cable for LIO-01 and LIO-02	JEPMC-W2061-A5-E	0.5	With a connector on the LIO-01/-02 end 	
	JEPMC-W2061-01-E	1.0		
	JEPMC-W2061-03-E	3.0		
I/O Cable for IO2310, IO2330, and MTD2310	JEPMC-W5410-05-E	0.5	With a connector on the IO2310/IO2330/MTD2310 end 	
	JEPMC-W5410-10-E	1.0		
	JEPMC-W5410-30-E	3.0		
I/O Cable for LIO-04, LIO-05, DO-01, and PO-01	JEPMC-W6060-05-E	0.5	With a connector on the LIO-04/LIO-05/DO-01 end 	
	JEPMC-W6060-10-E	1.0		
	JEPMC-W6060-30-E	3.0		
I/O cable for LIO-06	JEPMC-W2064-A5-E	0.5	With a connector on the LIO-06 end, 50 pins (With shielded wire) 	
	JEPMC-W2064-01-E	1.0		
	JEPMC-W2064-03-E	3.0		
Input Cable for AI-01	JEPMC-W6080-05-E	0.5	With a connector on the AI-01 end 	
	JEPMC-W6080-10-E	1.0		
	JEPMC-W6080-30-E	3.0		
Output Cable for AO-01	JEPMC-W6090-05-E	0.5	With a connector on the AO-01 end 	
	JEPMC-W6090-10-E	1.0		
	JEPMC-W6090-30-E	3.0		
I/O Cable for CNTR-01	JEPMC-W2063-A5-E	0.5	With a connector on the CNTR-01 end 	
	JEPMC-W2063-01-E	1.0		
	JEPMC-W2063-03-E	3.0		
EXIOIF Cable	JEPMC-W2094-A5-E	0.5	With connectors on both ends 	
	JEPMC-W2094-01-E	1.0		
	JEPMC-W2094-2A5-E	2.5		



## ● Optional Products

Applicable Unit	Product Name	Product Model	Specifications	Qty
CPU Module	Battery	JZSP-BA01	Supplied power to a calendar and backup memory when the power to the CPU unit is turned OFF.	
Base Unit	Protective cover	JEPMC-OP3301-E	Front cover for unused slot.	
	Unit base	JEPMC-OP2300S-E	Attachment for installing the machine controller (for screws).	
JEPMC-OP2400-E				
MECHATROLINK-II and MECHATROLINK-III Compatible Modules	DIN rail mounting parts	JEPMC-OP300	Used to mount the IO2310, IO2330, or MTD2310 Modules on the DIN rail (1 pair in a set).	

# International Standards



## ● MP3300 Main Units

●: Certified, ○: Complied

Classifications	Products	Model Name	Model	UL Standards	EU Directive	KC Mark
						
MP3300	CPU module	CPU-301 (16 axes)	JAPMC-CP3301-1-E	●	○	○
		CPU-301 (32 axes)	JAPMC-CP3301-2-E	●	○	○
		CPU-302 (16 axes)	JAPMC-CP3302-1-E	●	○	○
		CPU-302 (32 axes)	JAPMC-CP3302-2-E	●	○	○
	Base Unit	MBU-301	JEPMC-BU3301-E	●	○	○
		MBU-302	JEPMC-BU3302-E	●	○	○
		MBU-303	JEPMC-BU3303-E	●	○	○
		MBU-304	JEPMC-BU3304-E	●	○	○

## ● Optional Modules (Common for MP3000 and MP2000)



●: Certified, ○: Complied

Classifications	Products	Model Name	Model	UL Standards	EU Directive	KC Mark
						
CPU Module	Multiple-CPU module	MPU-01	JAPMC-CP2700-E	●	○	○
Connection Module	Expansion interface module	EXIOIF	JAPMC-EX2200-E	●	○	○
Motion Modules	Motion Module	SVC-01	JAPMC-MC2320-E	●	○	○
		SVB-01	JAPMC-MC2310-E	●	○	○
	Analog motion module	SVA-01	JAPMC-MC2300-E	●	○	○
	Pulse output motion module	PO-01	JAPMC-PL2310-E	●	○	○
Communication Modules	General-purpose serial communication module	217IF-01	JAPMC-CM2310-E	●	○	○
	Ethernet communication module	218IF-01	JAPMC-CM2300-E	●	○	○
		218IF-02	JAPMC-CM2302-E	●	○	○
	DeviceNet communication module	260IF-01	JAPMC-CM2320-E	●	○	○
	PROFIBUS communication module	261IF-01	JAPMC-CM2330-E	●	○	○
	FL-net communication module	262IF-01	JAPMC-CM2303-E	●	○	○
	EtherNet / IP communication module	263IF-01	JAPMC-CM2304-E	●	○	○
	EtherCAT communication module	264IF-01	JAPMC-CM2305-E	●	○	○
	CompoNet communication module	265IF-01	JAPMC-CM2390-E	●	○	○
	PROFINET communication module	266IF-01	JAPMC-CM2306-E	●	○	○
		266IF-02	JAPMC-CM2307-E	●	○	○
CC-Link IE Field Slave Module	269IF-01	JAPMC-CM2308-E	●	○	○	
MPLINK communication module	215AIF-01 MPLINK	JAPMC-CM2360-E	●	○	○	

(Cont'd)



● : Certified, ○ : Complied

Classifications	Products	Model Name	Model	UL Standards	EU Directive	KC Mark
						
I/O Modules	I/O module	LIO-01	JAPMC-IO2300-E	●	○	○
		LIO-02	JAPMC-IO2301-E	●	○	○
		LIO-04	JAPMC-IO2303-E	●	○	○
		LIO-05	JAPMC-IO2304-E	●	○	○
		LIO-06	JAPMC-IO2305-E	●	○	○
	Output module	DO-01	JAPMC-DO2300-E	●	○	○
	Analog input module	AI-01	JAPMC-AN2300-E	●	○	○
	Analog output module	AO-01	JAPMC-AN2310-E	●	○	○
MECHATROLINK-III Compatible Modules	Counter module	CNTR-01	JAPMC-PL2300-E	●	○	○
	Hub module	HUB	JEPMC-MT2000-E	●	○	○
	MECHATROLINK compatible gateway module	GW3100	JEPMC-GW3100-E	●	○	○
	64-point I/O module	MTD2310	JEPMC-MTD2310-E	●	○	○
	Analog input module	MTA2900	JEPMC-MTA2900-E	●	○	○
	Analog output module	MTA2910	JEPMC-MTA2910-E	●	○	○
	Pulse input module	MTP2900	JEPMC-MTP2900-E	●	○	○
	Pulse output module	MTP2910	JEPMC-MTP2910-E	●	○	○
MECHATROLINK-II Compatible Modules	Network analyzer module	MTNA-01	JEPMC-MT2010-E	●	○	○
	64-point I/O module	IO2310	JEPMC-IO2310-E	●	○	○
		IO2330	JEPMC-IO2330-E	●	○	○
	Counter module	PL2900	JEPMC-PL2900-E	●	○	○
	Pulse output module	PL2910	JEPMC-PL2910-E	●	○	○
	Analog input module	AN2900	JEPMC-AN2900-E	●	○	○
Analog output module	AN2910	JEPMC-AN2910-E	●	○	○	

### **Third-party Trademarks in this Catalog**

- Ethernet is a registered trademark of the Xerox Corporation.
- Windows is a trademark or registered trademark of the Microsoft Corporation.
- CompactFlash is a registered trademark of the SanDisk Corporation, and the CompactFlash and CF logos and trademarks are licensed at no charge and royalty-free to CompactFlash Association (CFA) members.
- MECHATROLINK is the trademark of MECHATROLINK Members Association.
- Camera Link is a registered trademark of the Automated Imaging Association (AIA).
- QR code is a registered trademark of Denso Wave Incorporated.

This catalog may contain other proprietary names and copyright notices.

Trademark symbols (TM and ®) do not appear with product or company names in this catalog.

# Read Before Ordering

## (1) Details of Warranty

### ■ Warranty Period

The warranty period for a product that was purchased (hereinafter called the “delivered product”) is one year from the time of delivery to the location specified by the customer or 18 months from the time of shipment from the Yaskawa factory, whichever is sooner.

### ■ Warranty Scope

Yaskawa shall replace or repair a defective product free of charge if a defect attributable to Yaskawa occurs during the above warranty period.

This warranty does not cover defects caused by the delivered product reaching the end of its service life and replacement of parts that require replacement or that have a limited service life.

This warranty does not cover failures that result from any of the following causes.

1. Improper handling, abuse, or use in unsuitable conditions or in environments not described in product catalogs or manuals, or in any separately agreed-upon specifications
2. Causes not attributable to the delivered product itself
3. Modifications or repairs not performed by Yaskawa
4. Use of the delivered product in a manner in which it was not originally intended
5. Causes that were not foreseeable with the scientific and technological understanding at the time of shipment from Yaskawa
6. Events for which Yaskawa is not responsible, such as natural or human-made disasters

## (2) Limitations of Liability

1. Yaskawa shall in no event be responsible for any damage or loss of opportunity to the customer that arises due to failure of the delivered product.
2. Yaskawa shall not be responsible for any programs (including parameter settings) or the results of program execution of the programs provided by the user or by a third party for use with programmable Yaskawa products.
3. The information described in product catalogs or manuals is provided for the purpose of the customer purchasing the appropriate product for the intended application. The use thereof does not guarantee that there are no infringements of intellectual property rights or other proprietary rights of Yaskawa or third parties, nor does it construe a license.
4. Yaskawa shall not be responsible for any damage arising from infringements of intellectual property rights or other proprietary rights of third parties as a result of using the information described in catalogs or manuals.

## (3) Suitability for Use

1. It is the customer’s responsibility to confirm conformity with any standards, codes, or regulations that apply if the Yaskawa product is used in combination with any other products.
2. The customer must confirm that the Yaskawa product is suitable for the systems, machines, and equipment used by the customer.
3. Consult with Yaskawa to determine whether use in the following applications is acceptable. If use in the application is acceptable, use the product with extra allowance in ratings and specifications, and provide safety measures to minimize hazards in the event of failure.
  - Outdoor use, use involving potential chemical contamination or electrical interference, or use in conditions or environments not described in product catalogs or manuals
  - Nuclear energy control systems, combustion systems, railroad systems, aviation systems, vehicle systems, medical equipment, amusement machines, and installations subject to separate industry or government regulations
  - Systems, machines, and equipment that may present a risk to life or property
  - Systems that require a high degree of reliability, such as systems that supply gas, water, or electricity, or systems that operate continuously 24 hours a day
  - Other systems that require a similar high degree of safety
4. Never use the product for an application involving serious risk to life or property without first ensuring that the system is designed to secure the required level of safety with risk warnings and redundancy, and that the Yaskawa product is properly rated and installed.
5. The circuit examples and other application examples described in product catalogs and manuals are for reference. Check the functionality and safety of the actual devices and equipment to be used before using the product.
6. Read and understand all use prohibitions and precautions, and operate the Yaskawa product correctly to prevent accidental harm to third parties.

## (4) Specifications Change

The names, specifications, appearance, and accessories of products in product catalogs and manuals may be changed at any time based on improvements and other reasons. The next editions of the revised catalogs or manuals will be published with updated code numbers. Consult with your Yaskawa representative to confirm the actual specifications before purchasing a product.

# MP3300

---

**IRUMA BUSINESS CENTER (SOLUTION CENTER)**

480, Kamifujisawa, Iruma, Saitama, 358-8555, Japan  
Phone +81-4-2962-5151 Fax +81-4-2962-6138  
<http://www.yaskawa.co.jp>

**YASKAWA AMERICA, INC.**

2121, Norman Drive South, Waukegan, IL 60085, U.S.A.  
Phone +1-800-YASKAWA (927-5292) or +1-847-887-7000 Fax +1-847-887-7310  
<http://www.yaskawa.com>

**YASKAWA ELÉTRICO DO BRASIL LTDA.**

777, Avenida Piraporinha, Diadema, São Paulo, 09950-000, Brasil  
Phone +55-11-3585-1100 Fax +55-11-3585-1187  
<http://www.yaskawa.com.br>

**YASKAWA EUROPE GmbH**

Hauptstraße 185, 65760 Eschborn, Germany  
Phone +49-6196-569-300 Fax +49-6196-569-398  
<http://www.yaskawa.eu.com> E-mail: [info@yaskawa.eu.com](mailto:info@yaskawa.eu.com)

**YASKAWA ELECTRIC KOREA CORPORATION**

35F, Three IFC, 10 Gukjegeumyung-ro, Yeongdeungpo-gu, Seoul, 07326, Korea  
Phone +82-2-784-7844 Fax +82-2-784-8495  
<http://www.yaskawa.co.kr>

**YASKAWA ELECTRIC (SINGAPORE) PTE. LTD.**

151, Lorong Chuan, #04-02A, New Tech Park 556741, Singapore  
Phone +65-6282-3003 Fax +65-6289-3003  
<http://www.yaskawa.com.sg>

**YASKAWA ELECTRIC (THAILAND) CO., LTD.**

59, 1st-5th Floor, Flourish Building, Soi Ratchadapisek 18, Ratchadapisek Road, Huaykwang, Bangkok 10310, Thailand  
Phone: +66-2-017-0099 Fax: +66-2-017-0799  
<http://www.yaskawa.co.th>

**YASKAWA ELECTRIC (CHINA) CO., LTD.**

22F, One Corporate Avenue, No.222, Hubin Road, Shanghai, 200021, China  
Phone +86-21-5385-2200 Fax +86-21-5385-3299  
<http://www.yaskawa.com.cn>

**YASKAWA ELECTRIC (CHINA) CO., LTD. BEIJING OFFICE**

Room 1011, Tower W3 Oriental Plaza, No.1, East Chang An Ave.,  
Dong Cheng District, Beijing, 100738, China  
Phone +86-10-8518-4086 Fax +86-10-8518-4082

**YASKAWA ELECTRIC TAIWAN CORPORATION**

12F, No. 207, Sec. 3, Beishin Rd., Shindian Dist., New Taipei City 23143, Taiwan  
Phone: +886-2-8913-1333 Fax: +886-2-8913-1513 or +886-2-8913-1519  
<http://www.yaskawa.com.tw>

---

**YASKAWA****YASKAWA ELECTRIC CORPORATION**

In the event that the end user of this product is to be the military and said product is to be employed in any weapons systems or the manufacture thereof, the export will fall under the relevant regulations as stipulated in the Foreign Exchange and Foreign Trade Regulations. Therefore, be sure to follow all procedures and submit all relevant documentation according to any and all rules, regulations and laws that may apply. Specifications are subject to change without notice for ongoing product modifications and improvements.

© 2014 YASKAWA ELECTRIC CORPORATION

LITERATURE NO. KAEP C880725 03D <3>-1

Published in Japan April 2018  
17-3-17