

YASKAWA

AC SERVO DRIVES LARGE-CAPACITY Σ -V SERIES

200 V 22 to 37 kW
400 V 22 to 55 kW
Servomotor SGMV
SERVOPACK SGD



Powerful
&
Smart

Certified for
ISO9001 and
ISO14001



JQA-0422 JQA-EM0202

Powerful & Smart

Strongest Σ -V line-up ever ! Newest Σ -V servo drives increase speeds & improve performance with cleaner, lighter, & more compact equipment.
Easy to use & easy to set up with Σ -V high standard of excellence !

Separated converter

Compatible with a wide variety of reference interfaces*
* : Will be released in succession.

20-bit serial encoder

30% smaller than Σ -II amplifiers

Compliance with Global Standards

Supports newest Σ -V functions and option modules



Applicable worldwide in Europe, North America, and Asia.

SGDV SERVOPACKS	CE	UL LISTED	RoHS compliant	Safety standard compliant*
SGMVV Servomotor	CE	UL LISTED	RoHS compliant	

* : For detail, contact your yaskawa representative.

A wide range of standard models in the Σ -V-series rotational servomotor lineup.

The lineup includes models from 3.3 W to 55 kW.



Model	Capacity	Inertia	Motor Rated Output
SGMVV	Large	Small	22 to 55 kW
SGMZS	EX flameproof* type		0.2 to 3 kW
SGMGV	Medium	Medium	0.3 to 15 kW
SGMSV	Medium	Low	1 to 7 kW
SGMPS	Small	Medium	0.1 to 1.5 kW
SGMAV	Small	Low	50 W to 1 kW
SGMJV	Small	Medium	50 to 750 W
SGMMV	Ultra-Small	Low	3.3 to 30 W

* : ATEX flameproof servomotor, SGMZH model, are also available.

Let Yaskawa help you build the system you need.

Advantage

Upgrade large-scale equipment

Main Applications

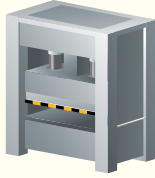

• Servo presses

Promote cleaner and more-efficient operation by converting from hydraulic drives to electric drives. You can also save energy by using power regeneration converters.

• Rotary Cutters

Outstanding acceleration/deceleration torque for high-speed tracking

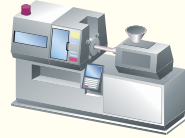

• Injection molding machines

The use of a high-resolution encoder provides high-precision injection control to increase forming quality.

• Metal processing machines

Yaskawa can help you increase the precision of equipment that requires high torque, such as to bend and stretch metal.

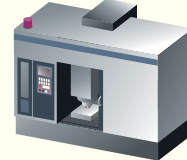

• Machine Tools

Helps meet speed and capacity demands of feed and spindle motors in high-speed, heavy-duty machining applications.

• Wire Saws

With a greater cutting force due to the high torque, those saws can now cut hard materials. When combined with the MP series, it is possible to synchronize roller shafts, wind-up shafts and other such parts to a high level of precision.

Advantage

Upgrade even farther by combining a Machine Controller

Advantages of Combining with the MP Series

- High torque can be generated with synchronized control of multiple axes.
- The high-precision synchronized control of multiple axes (roller, takeup, etc.) increases quality.
- Seamless switching between position control and torque control improves machine takt time.

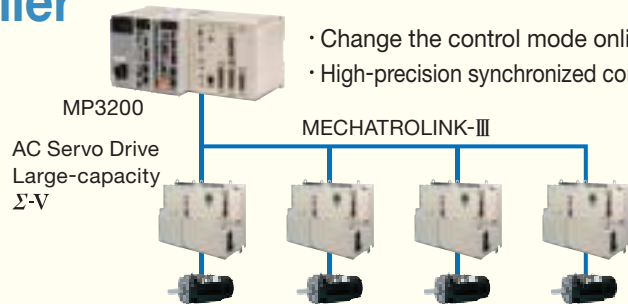

- Change the control mode online.
- High-precision synchronized control

Advantage

Easily build an energy-saving system

The Σ -V SERVOPACKs for use with large-capacity models use separate converters. By combining with a D1000 high-efficiency power regeneration converter, you can achieve an energy-saving system.

- Regenerative energy that is produced when decelerating the motor is returned to the power supply to effectively use energy.
- You can combine multiple Servomotors to effectively use regenerative energy between the Servo axes. This energy would be lost for individual axis operation.

Related Product High-power Factor Converter with Power Regeneration ($K_s=0$)

D1000

RoHS Compliant
Restriction of Hazardous Substances Directive

UL LISTED CE SPS

Note: Application pending.

Energy-saving Application Example

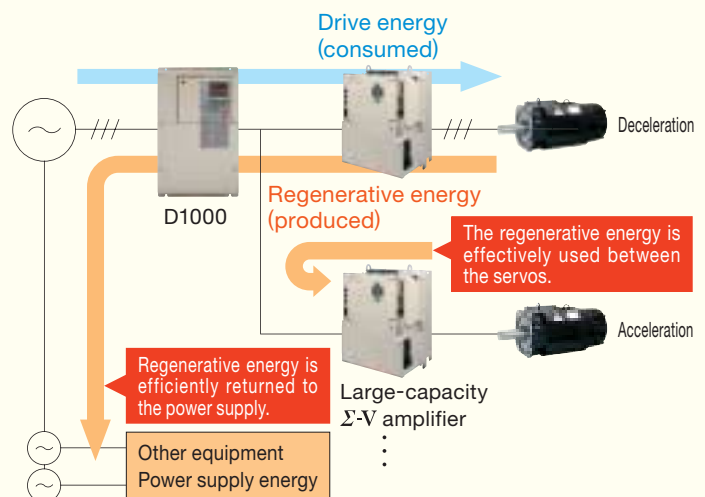

Take advantage of Σ -V-series performance and easy operation.

Superlative Performance

Improve the performance of machines that require high torque

The response and wealth of functions of the industry's top class of amplifiers shorten positioning time.

Vibration Suppression

If vibration occurs in the mechanical drive system, the Observer reduces it and suppresses machine vibration.

Friction Compensation

Even if the load changes, variations in the position error are suppressed without any changes to the gain setting.

Model Follow-up Control

Even for machines with low rigidity, control operation matched to the machine improves following performance and shortens the stabilization period.

Yaskawa's compact, low-inertia servomotors can empower your machines.

The new SGMVV Servomotors are available with rated outputs from 22 to 55 kW and rated speeds of 800 and 1,500 min⁻¹.

The encoder with a 20-bit resolution increases machine precision.



Various Functions



17 bit

20 bit

Outstanding Expandability

Smooth integration into systems

Standard support for four different SERVOPACK types

- Analog voltage/pulse train reference
- MECHATROLINK-III communication reference
- MECHATROLINK-II communication reference
- Command option attachable type

Compliant with applicable safety standards

Easy compliance with machine safety standards

Wide selection of option modules for various communication interfaces and feedback

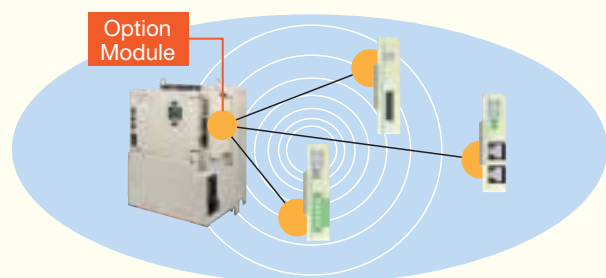

Simple Start-up

Unbelievably easy servo tuning



Simple Tuning

Data tracing

You can check the results of tuning in realtime through USB.

Get up and running quickly after hooking up the motor
New Tuning-less Function

Even without servo adjustment and with load changes, oscillation- and vibration-free drive is possible up to the allowable load moment of inertia.

Minimize setting time with less vibration
New Advanced Autotuning

The feedback gain adjustment functions have a new automatic feed forward gain adjustment for optimal adjustment performance. The friction compensation function automatically cancels out the effect of friction on machine characteristics.

Fine-tuning is a must
New "One-parameter" Tuning

Fine-tuning can tweak machine performance to the max.

Product Line-Up

Servomotors



Voltage	200 V		400 V	
	Rated Output	22 kW to 37 kW		22 kW to 45 kW
Rated Speed/ Max. Speed (min ⁻¹)	800/ 1300	1500/ 2000	800/ 1300	1500/ 2000

SERVOPACKs



Control Method	Speed, Torque, Position	
	Power Supply Voltage	200 V
Applicable Servomotor Max. Capacity	22 kW to 37 kW	22 kW to 55 kW

Converter



Power Supply Voltage	200 V	400 V
	Applicable Servomotor Max. Capacity	22 kW, 37 kW

Combinations

Voltage	Rated Output	200 V			400 V				
		Servomotor	22 kW	30 kW	37 kW	22 kW	30 kW	37 kW	45 kW
	SGMVV-□□□□	2BA	3ZA	3GA	2BD	3ZD	3GD	4ED	5ED
SERVOPACK	SGDV-□□□□	121H	161H	201H	750J		101J	131J	
Converter	SGDV-COA:□□□□	2BAA	3GAA		3ZDA		5EDA		

Large-capacity Σ -V Series Model Designation

Servomotors

SGMVV-2B A D B 2 N

SGMVV
 Rated Output
 2B : 22 kW
 3Z : 30 kW
 3G : 37 kW
 4E : 45 kW
 5E : 55 kW
 Power Supply Voltage
 A : 200 VAC
 D : 400 VAC
 Serial Encoder
 D : 20-bit incremental
 3 : 20-bit absolute

Options
 N : Without options
 1 : With dust seal
 S : With oil seal
 B : With holding brake (90 VDC)
 C : With holding brake (24 VDC)
 D : With holding brake (90 VDC) and oil seal
 E : With holding brake (24 VDC) and oil seal
 F : With holding brake (90 VDC) and dust seal
 G : With holding brake (24 VDC) and dust seal

Main Mechanical Structure
 2 : Flange type, straight shaft end without key and no tap
 6 : Flange type, straight shaft end with key and tap
 K : Foot-mounted type, straight shaft end without key and no tap
 L : Foot-mounted type, straight shaft end with key and tap

Rated Speed
 B : 1500 min⁻¹
 D : 800 min⁻¹

Note: Production range of machine application models and models with brakes for rated output

Rated Speed [min ⁻¹]	Rated Output [kW]	Voltage		Oil Seal*, Dust Seal	Optional Specifications	
		200 V	400 V		With Brakes	
					Flange-mounted Type	Foot-mounted Type
1500	22	✓	✓	✓	✓	✓
	30	✓	✓	✓	✓	✓
	37	✓	✓	✓	✓	✓
	45	—	✓	✓	✓	✓
	55	—	✓	✓	—	✓
800	22	✓	✓	✓	✓	✓
	30	✓	✓	✓	—	✓
	37	✓	✓	✓	—	✓
	45	—	✓	✓	—	—

✓ : Production possible, — : Production not possible.

* : Servomotors with oil seals are available with flange mounting only.

SERVOPACKs

SGDV-750 J 01 A 000 00 0

Σ -V Series
 SGD V SERVOPACK
 Current

Voltage	Code	Applicable Servomotor Max. Capacity kW
Three-phase 200 V	121	22
	161	30
	201	37
Three-phase 400 V	750	30
	101	37
	131	55

Options*¹
 Options (parameters)
 0 : standard
 Options (software)
 00 : standard
 Options (hardware)

Code	Specifications
000	Base-mounted (standard)
001	Duct-ventilated
002	Varnished
003	Duct-ventilated and varnished

 Design Revision Order
 A, B...

Power Supply Voltage*²
 H : 200 V class
 J : 400 V class

Interface

Code	Specifications
01	Analog voltage/pulse train reference (for rotary servomotors)
11	MECHATROLINK-II communications reference (for rotary servomotors)
21	MECHATROLINK-III communications reference (for rotary servomotors)
E1	Command option attachable type (for rotary servomotors)

*1 : If the option codes are all zeros, the zeros are omitted.

*2 : DC power from the Separate converter unit

Converters

SGDV-COA 3ZD A 000000

Σ -V Series
 Product Section

Code	Specifications
COA	Resistive regenerative converter

 Power Capacity

Voltage	Code	Applicable Servomotor Max. Capacity kW
Three-phase 200 V	2BA	22
	3GA	37
Three-phase 400 V	3ZD	30
	5ED	55

 Options*
 Options (hardware)

Code	Specifications
000000	Base-mounted (standard)
001000	Duct-ventilated
002000	Varnished
003000	Duct-ventilated and varnished

 Design Revision Order
 A, B...

* : If the option codes are all zeros, the zeros are omitted.

Option Module

SGDV-OSA01 A

Σ -V Series
 Design Revision Order
 A
 Module Type

Code	Module
OSA01	Safety module
OFA01	Fully-closed module
Command option module*	
OCA03	INDEXER
OCA04	DeviceNet (Driven by SERVOPACK control power supply)
OCA05	DeviceNet (Driven by external power supply)

* : These modules can be mounted in command option attachable type SERVOPACKs (Model SGD V-□□□□E1A) for use. For more information, refer to the *Combination of SERVOPACKs and Option Modules* (page 42).

Servomotors	Ratings and Specifications	8	8		
	Precautions on Servomotor Installation	11			
	Mechanical Specifications	13			
	Holding Brake Delay Time	14			
	External Dimensions	15			
SERVOPACKs	Analog Voltage/Pulse Train Ref. Type (SGDV-□□□□01□)	20	20		
	MECHATROLINK-Ⅱ Communications Ref. Type (SGDV-□□□□11□)	24			
	MECHATROLINK-Ⅲ Communications Ref. Type (SGDV-□□□□21□)	28			
	Command Option Attachable Type (SGDV-□□□□E1□)	32			
	External Dimensions	36			
Converters	Ratings and Specifications	38	38		
	External Dimensions	39			
	External Dimensions: Combinations of SERVOPACKs and Converters	41			
Option Modules	Combination of SERVOPACKs and Option Modules	42	42		
	Safety Module: Model SGDV-OSA01A	43			
	Fully-closed Module: Model SGDV-OFA01A	44			
	Command Option Modules INDEXER: Model SGDV-OCA03A	49			
	Command Option Modules DeviceNet: Model SGDV-OCA04A, OCA05A	50			
Selecting Cables	System Configuration	52	Battery Case	65	52
	Selecting Cables	53	Cable for Safety Module (Option)	66	
	Details of Cables	60	Cable for INDEXER Module (Option)	67	
Wiring Main Circuit	Typical Main Circuit Wiring Examples	70	70		
	General Precautions for Wiring	71			
	SERVOPACK Main Circuit Wire	72			
Peripheral Devices	Molded-case Circuit Breaker and Fuse Capacity	74	Surge Absorbers for Holding Brakes, Diodes, and Open/Close Relays	78	74
	Noise Filters	75	Regenerative Resistor	79	
	Surge Absorber	76	Dynamic Brake Unit	81	
	Holding Brake Power Supply Unit	77			
Capacity Selection	Servomotor Capacity Selection Examples	84	84		
	Regenerative Resistor Capacity Selection	88			
Others	Example of Connection to Machine Controller MP2□□□	92	92		
	Example of Connection to SVA-01 Motion Module for MP2200/MP2300	93			
	Harmonized Standards	94			
	Warranty	95			

Servomotors

Ratings and Specifications

Time Rating: Continuous

Vibration Class: V15

Insulation Resistance: 500 VDC, 10 MΩ min.

Ambient Temperature: 0°C to 40°C

Excitation: Permanent magnet

Mounting: Flange-mounted
Foot-mounted

Thermal Class: F

Withstand Voltage: 1500 VAC for one minute (200-V class)
1800 VAC for one minute (400-V class)

Enclosure: Totally enclosed, separately cooled, IP44
(except for shaft opening)

Ambient Humidity: 20% to 80% (no condensation)

Rotation Direction: Counterclockwise (CCW) with forward run
reference when viewed from the load side

200-V Class

Servomotor Model: SGMV-□□□□□		2BA□B	3ZA□B	3GA□B	2BA□D	3ZA□D	3GA□D
Rated Output*	kW	22	30	37	22	30	37
Rated Torque*	N·m	140	191	236	262	358	442
Stall Torque*	N·m	140	191	236	262	358	442
Instantaneous Peak Torque*	N·m	350	478	589	526	752	930
Rated Current*	Arms	88	120	152	104	150	195
Instantaneous Max. Current*	Arms	240	340	460	240	340	460
Rated Speed*	min ⁻¹	1500			800		
Max. Speed*	min ⁻¹	2000			1300		
Torque Constant	N·m/Arms	1.72	1.72	1.68	2.73	2.50	2.34
Rotor Moment of Inertia	×10 ⁻⁴ kg·m ²	366 (451)	498 (583)	595 (665)	705 (775)	1290 (1448)	1564 (1722)
Rated Power Rate*	kW/s	536 (434)	733 (626)	933 (836)	977 (888)	996 (885)	1250 (1135)
Rated Angular Acceleration*	rad/s ²	3830 (3100)	3840 (3280)	3960 (3550)	3720 (3380)	2780 (2470)	2830 (2570)
Applicable SERVOPACK	SGDV-□□□□□	121H	161H	201H	121H	161H	201H
Applicable Converter	SGDV-COA□□□□□	2BAA	3GAA	3GAA	2BAA	3GAA	3GAA

* : These items and torque-motor speed characteristics quoted in combination with a SERVOPACK are at an armature winding temperature of 20°C.

Notes: 1 The values in parentheses are for servomotors with holding brakes.

2 The above specifications show the values under the cooling condition when the following heat sinks are mounted on the servomotors.

SGMVV-2BA□B/-3ZA□B/-3GA□B/-2BA□D: 650×650×35 mm (iron)

SGMVV-3ZA□D/-3GA□D: 740×520×27 mm (iron)

400-V Class

Servomotor Model: SGMV-□□□□□		2BD□B	3ZD□B	3GD□B	4ED□B	5ED□B	2BD□D	3ZD□D	3GD□D	4ED□D	
Rated Output*	kW	22	30	37	45	55	22	30	37	45	
Rated Torque*	N·m	140	191	236	286	350	262	358	442	537	
Stall Torque*	N·m	140	191	236	286	350	262	358	442	537	
Instantaneous Peak Torque*	N·m	350	478	589	715	875	526	752	930	1182	
Rated Current*	Arms	44	60	76	102	117	52	75	98	110	
Instantaneous Max. Current*	Arms	120	170	230	280	340	120	170	230	280	
Rated Speed*	min ⁻¹	1500					800				
Max. Speed*	min ⁻¹	2000					1300				
Torque Constant	N·m/Arms	3.44	3.44	3.37	3.09	3.15	5.46	5.00	4.68	5.21	
Rotor Moment of Inertia	×10 ⁻⁴ kg·m ²	366 (451)	498 (583)	595 (665)	1071 (1229)	1290 (1448)	705 (775)	1290 (1448)	1564 (1722)	1804	
Rated Power Rate*	kW/s	536 (434)	733 (626)	935 (836)	765 (667)	949 (847)	977 (888)	996 (885)	1250 (1135)	1600	
Rated Angular Acceleration*	rad/s ²	3830 (3100)	3840 (3280)	3970 (3550)	2670 (2330)	2710 (2420)	3720 (3380)	2780 (2470)	2830 (2570)	2980	
Applicable SERVOPACK	SGDV-□□□□□	750J	750J	101J	131J	131J	750J	750J	101J	131J	
Applicable Converter	SGDV-COA□□□□□	3ZDA	3ZDA	5EDA	5EDA	5EDA	3ZDA	3ZDA	5EDA	5EDA	

* : These items and torque-motor speed characteristics quoted in combination with a SERVOPACK are at an armature winding temperature of 20°C.

Notes: 1 The values in parentheses are for servomotors with holding brakes.

2 The above specifications show the values under the cooling condition when the following heat sinks are mounted on the servomotors.

SGMVV-2BD□B/-3ZD□B/-3GD□B/-2BD□D: 650×650×35 mm (iron)

SGMVV-4ED□B/-5ED□B/-3ZD□D/-3GD□D/-4ED□D: 740×520×27 mm (iron)

Ratings and Specifications

● **Torque-Motor Speed Characteristics** **A**: Continuous Duty Zone **B**: Intermittent Duty Zone

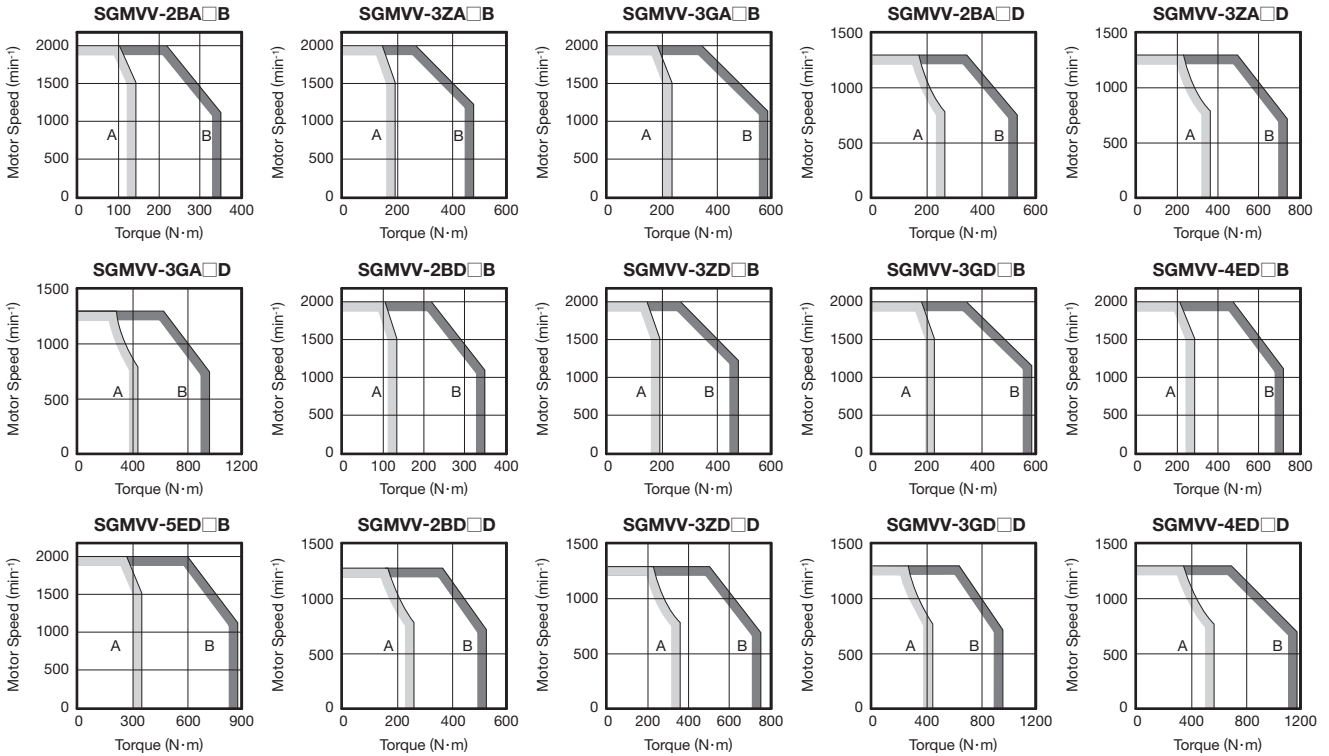

Notes: 1 When the effective torque is within the rated torque, the servomotor can be used within the intermittent duty zone.
 2 When the main circuit cable length exceeds 20 m, note that the intermittent duty zone of the *Torque-Motor Speed Characteristics* will shrink as the line-to-line voltage drops.

● **Holding Brake Electrical Specifications**

Servomotor Model SGMVV-	Rated Speed min ⁻¹	Rated Output kW	Holding Torque N·m	Holding Brake Specifications			
				Rated Voltage 24 VDC		Rated Voltage 90 VDC	
				Capacity W	Rated Current A (at 20°C)	Capacity W	Rated Current A (at 20°C)
2B	1500	22	238	54	2.24	54	0.60
3Z		30	238	54	2.24	54	0.60
3G		37	345	54	2.24	54	0.60
4E		45	429	60	2.50	60	0.67
5E		55	429	60	2.50	60	0.67
2B	800	22	345	54	2.24	54	0.60
3Z		30	429	60	2.50	60	0.67
3G		37	573	60	2.50	60	0.67

Notes: 1 The holding brake is only used to hold the load and cannot be used to stop the servomotor.
 2 The holding brake open time and holding brake operation time vary depending on which discharge circuit is used. Make sure holding brake open time and holding brake operation time are correct for your servomotor.
 3 A 24-VDC power supply is not included.
 4 For information on a 90-VDC power supply, refer to page 77.

● **Cooling Fan Specifications**

Main Circuit Power Supply Voltage	Servomotor Model SGMVV-	Specifications		
		Frequency Hz	Rated Input W	Rated Current A
Three-phase 200 VAC	2BA	50	100	0.29
		60	140	0.40
	3ZA	50	100	0.29
		60	140	0.40
	3GA	50	100	0.29
		60	140	0.40
Three-phase 400 VAC	2BD	50	75	0.14
		60	105	0.16
	3ZD	50	75	0.14
		60	105	0.16
	3GD	50	75	0.14
		60	105	0.16
	4ED	50	75	0.14
		60	105	0.16
	4ED	50	130	0.38
		60	170	0.36
	5ED	50	75	0.14
		60	105	0.16

Ratings and Specifications

● Overload Characteristics

The overload detection level is set under hot start conditions at a servomotor ambient temperature of 40°C.

Motors with Rated Speed of 1,500 min⁻¹

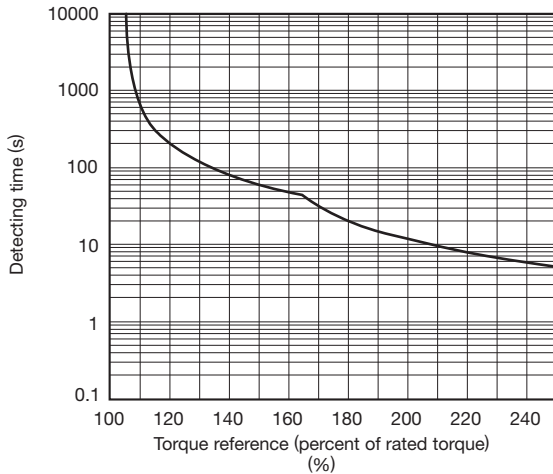

Motors with Rated Speed of 800 min⁻¹

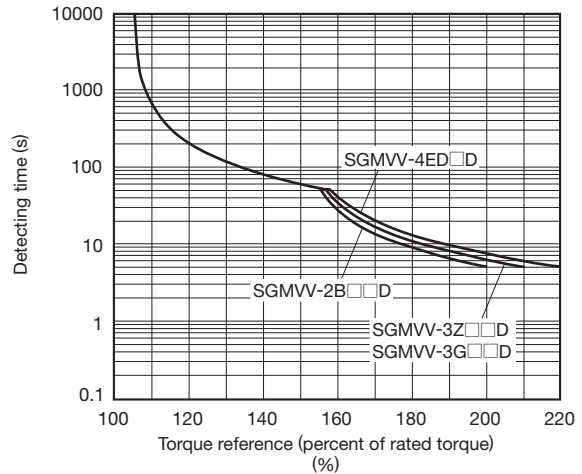

Note: Overload characteristics shown above do not guarantee continuous duty of 100% or more output. Use a servomotor with effective torque within the continuous duty zone of *Torque-Motor Speed Characteristics*.

● Allowable Load Moment of Inertia at the Motor Shaft

The rotor moment of inertia ratio is the value for a servomotor without a gear and a holding brake.

Servomotor Model SGMVV-	Servomotor Rated Output	Allowable Load Moment of Inertia (Rotor Moment of Inertia Ratio)
2B to 5E	22 to 55 kW	10 times

● Load Moment of Inertia

The larger the load moment of inertia, the worse the movement response.

The allowable load moment of inertia (J_L) depends on the motor capacity, as shown above. This value is provided strictly as a guideline and results may vary depending on servomotor drive conditions.

Use the AC servo drive capacity selection program SigmaSize+ to check the operation conditions. The program can be downloaded for free from our web site (<http://www.e-mechatronics.com/>).

An overvoltage alarm (A.400) or a regeneration overload alarm (A.320) is likely to occur during deceleration if the load moment of inertia exceeds the allowable load moment of inertia. Take one of the following steps if this occurs.

- Reduce the torque limit.
- Reduce the deceleration rate.
- Reduce the maximum speed.

If you cannot clear the alarm with the above steps, consider changing the capacity of the external regenerative resistor. Refer to *Regenerative Resistor Capacity Selection*.

● Allowable Radial and Thrust Loads

Design the mechanical system so thrust and radial loads applied to the servomotor shaft end during operation fall within the ranges shown in the table.

Servomotor Model SGMVV-	Rated Speed min ⁻¹	Allowable Radial Load (Fr) N	Allowable Thrust Load (Fs) N	LR mm	Reference Diagram
2B□□B	1500	5880	2156	100	
3Z□□B		6272	2156	100	
3G□□B		7448	2156	100	
4ED□B		7840	2156	100	
5ED□B		8428	2156	110	
2B□□D	800	7448	2156	100	
3Z□□D		8428	2156	110	
3G□□D		8428	2156	110	
4ED□D		10100	2156	120	

Precautions on Servomotor Installation

The service life of the servomotor will be shortened or unexpected problems will occur if the servomotor is installed incorrectly or in an inappropriate location. Always observe the following installation instructions.

CAUTION
<ul style="list-style-type: none"> · Do not connect the servomotor directly to a commercial power line. This will damage the servomotor. The servomotor cannot operate without the proper SERVOPACK.

(1) Installation Environment

Items	Condition
Ambient Temperature	0 to 40°C (no freezing)
Ambient Humidity	20% to 80%RH (no condensation)
Installation Site	<ul style="list-style-type: none"> <li style="width: 50%;">· Free of corrosive or explosive gases. <li style="width: 50%;">· Elevation: 1,000 m max. <li style="width: 50%;">· Well-ventilated and free of dust and moisture. <li style="width: 50%;">· Free of high magnetic field <li style="width: 50%;">· Facilitates inspection and cleaning.
Storage Environment	Store the servomotor in the following environment if it is stored with the power cable disconnected. Ambient temperature during storage: -20 to +60°C (no freezing) Ambient humidity during storage: 20% to 80%RH (no condensation)

(2) Enclosure

The enclosure* of the servomotor is totally enclosed, separately cooled IP44.
 * : Except through shaft section. The enclosure specification can be satisfied only when using a specified cable.

- Do not use servomotors in a location that is subject to oil. If the servomotor is used in a location that is subject to water or oil mist, order a servomotor with an oil seal to seal the through shaft section.

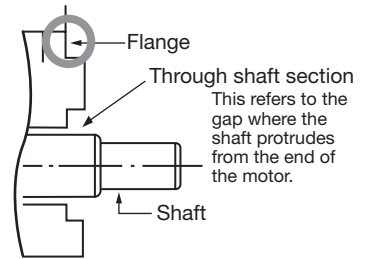

Precautions on Using Servomotor with Oil Seal:

- Put the oil surface under the oil seal lip.
- Use the oil seal in favorably lubricated condition.
- When using the servomotor with its shaft upward direction, be sure that oil will not stay in the oil seal lip.

(3) Orientation

- The allowable mounting directions of the servomotor depend on the mounting method.

Mounting Method	Holding Brake	Allowable Mounting Directions
Flange-mounted	No	Vertical or horizontal
	Yes	
Foot-mounted	No	Horizontal
	Yes	

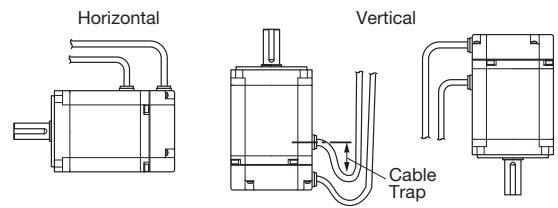

Note: When installing servomotors vertically, make cable traps to keep out water. When mounting servomotors with the shaft up, take measures with the connected machine to prevent oil from getting into the servomotors through gear boxes etc.

- Servomotor Fan Installation Space
 To prevent decreasing the cooling capacity of the servomotor fan, provide a space of at least 200 mm on the air inlet side of the servomotor as shown in the figure at the right.

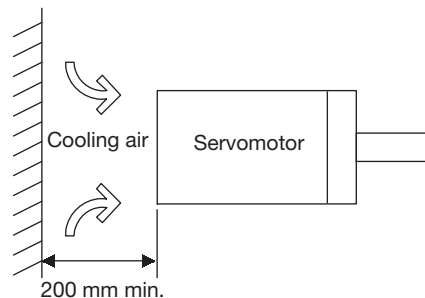

Precautions on Servomotor Installation

(4) Alignment

Align the shaft of the servomotor with the shaft of the equipment, and then couple the shafts.

IMPORTANT

- 1 Install the servomotor so that alignment accuracy falls within the following range. Vibration that will damage the bearings and encoders if the shafts are not properly aligned.

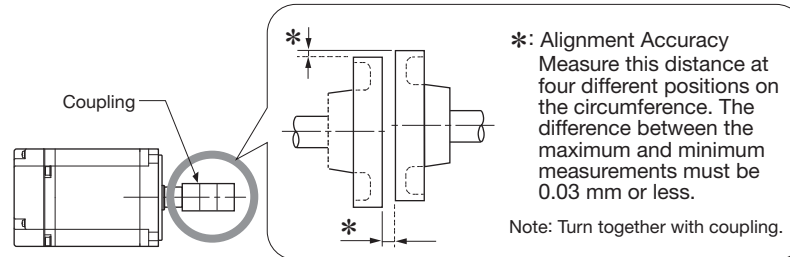

- 2 Do not allow any direct impact to the shafts when installing the couplings. Do not hit the area near encoders with a hammer etc., as impacts may damage the encoders.

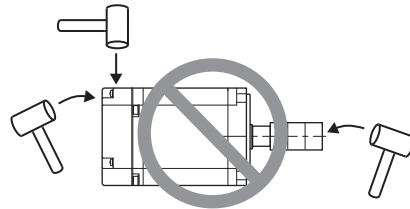

- 3 Before installation, thoroughly remove the anticorrosive paint from the end of the motor shaft. Only after removing the paint can servomotors be installed on the machines.



(5) Cable Stress

- Make sure there is no bending or tension on the cables themselves, the connections, or the cable lead inlets. Be especially careful to wire encoder cables so that they are not subject to stress because the core wires of encoder cables are very thin at only 0.2 to 0.3 mm².

(6) Precautions on Cable Usage

Observe the following precautions:

- When you connect the cables to the servomotor, connect the servomotor's main circuit cable first. If you connect the encoder cable first, the encoder may be damaged due to the difference in electrical potential from the FG.
- Make sure there is no foreign matters such as dust and metal chips in the connector before connecting.
- Do not apply shock to connectors. Otherwise, they may be damaged.
- Before you connect the wires, make sure that there are no mistakes in the wiring.
- Be sure not to apply stress on the connector. The connector may be damaged by stress.
- If you move the servomotor while the cables are connected, always hold onto the main body of the servomotor. If you lift the servomotor by the cables when you move it, the terminals may be damaged or the cables may be broken.

Mechanical Specifications

● Mechanical Tolerance T.I.R. (Total Indicator Reading)

The following figure shows tolerances for the servomotor's output shaft and installation area. For more details on tolerances, refer to the external dimensions of the individual servomotor.

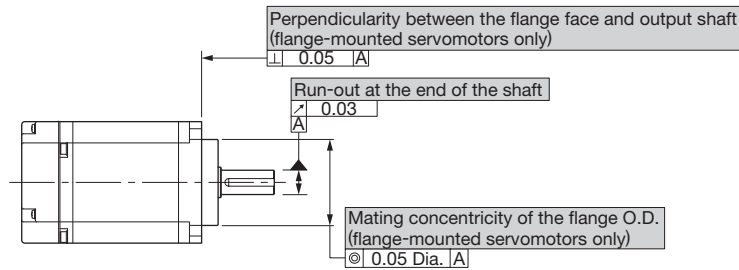

● Direction of Servomotor Rotation

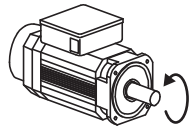

Counterclockwise

Positive rotation of the servomotor is counterclockwise when viewed from the load. The direction of rotation can be reversed by changing the SERVOPACK parameters.

● Shock Resistance

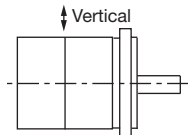

Impact Applied to the Servomotor

Mount the servomotor with the axis horizontal. The servomotor will withstand the following vertical impacts:

- Impact Acceleration: 490 m/s^2
- Impact occurrences: 2

● Vibration Resistance

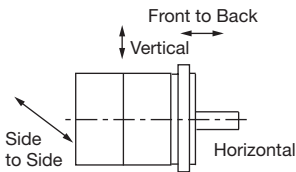

Impact Applied to the Servomotor

Mount the servomotor with the axis horizontal. The servomotor will withstand the following vibration acceleration in three directions: Vertical, side to side, and front to back.

- Vibration Acceleration: 24.5 m/s^2

IMPORTANT

The amount of vibration the servomotor endures will vary depending on the application. Check the vibration acceleration being applied to your servomotor for each application.

● Vibration Class

The vibration class for the servomotors at rated motor speed is V15.

(A vibration class of V15 indicates a total vibration amplitude of $15 \mu\text{m}$ maximum on the servomotor during rated rotation.)

Holding Brake Delay Time

Holding brakes have motion delay time that varies depending on when the brake is open and when the brake is operating. The following table shows the brake delay time of each servomotor.

IMPORTANT

Make sure the holding brake delay time is correct for your servomotor.

- Example, switching the holding brakes on the DC side

Main Circuit Power Supply Voltage	Servomotor Model SGMVV-	Rated Speed min ⁻¹	Voltage	Brake Open Time ms	Brake Operation Time ms	
Three-phase 200 VAC	2BA□B	1500	24 VDC or 90 VDC	500 max.	150 max.	
	3ZA□B					
	3GA□B					
	2BA□D	800		550 max.	320 max.	
	3ZA□D			700 max.	320 max.	
	3GA□D					
Three-phase 400 VAC	2BD□B	1500		24 VDC or 90 VDC	500 max.	150 max.
	3ZD□B					
	3GD□B					
	4ED□B					
	5ED□B	800			550 max.	320 max.
	2BD□D				500 max.	150 max.
	3ZD□D		550 max.		320 max.	
	3GD□D		700 max.		320 max.	
4ED□D						

* : An SGMVV-4ED□D servomotor is not available in a model with a holding brake.

External Dimensions Units: mm

● Flange-mounted Servomotors without Holding Brakes

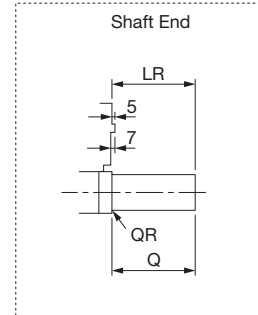
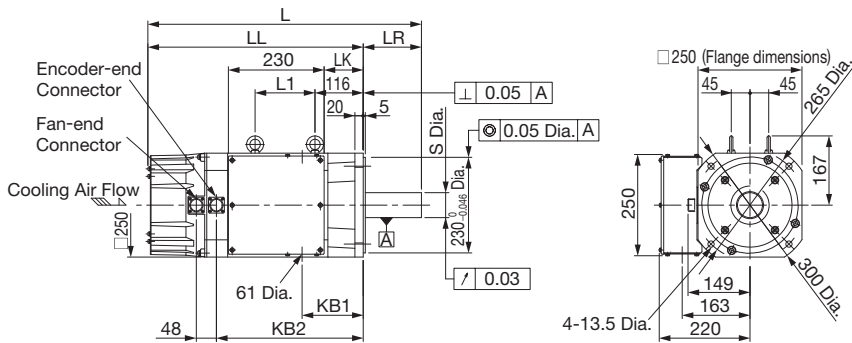

For the specifications of the other shaft ends, refer to page 19.

Servomotor Model SGMVV-	Rated Speed min ⁻¹	L	LL	LR	LK	L1	KB1	KB2	S Dia.	Q	QR	Approx. Mass kg
2B□□B	1500	658	518	140	94	144	147	353	60 ^{+0.030} _{+0.011}	140	1.6	95
3Z□□B		704	564	140	140	190	193	399	60 ^{+0.030} _{+0.011}	140	1.6	110
3G□□B		744	604	140	180	230	233	439	65 ^{+0.030} _{+0.011}	140	1.2	120
2B□□D	800	794	654	140	230	280	283	489	65 ^{+0.030} _{+0.011}	140	1.2	135

Note: Models with oil seals are of the same configuration.

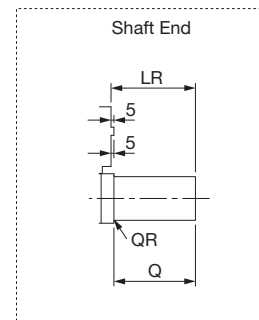
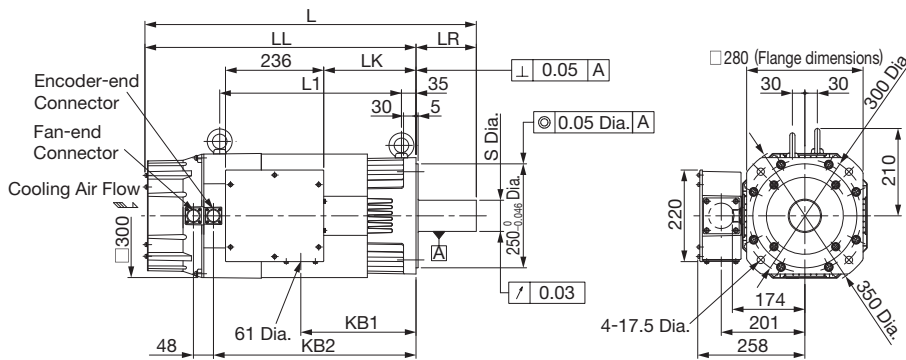

For the specifications of the other shaft ends, refer to page 19.

Servomotor Model SGMVV-	Rated Speed min ⁻¹	L	LL	LR	LK	L1	KB1	KB2	S Dia.	Q	QR	Approx. Mass kg
4ED□B	1500	797	652	145	222	437	277	487	75 ^{+0.030} _{+0.011}	140	2.5	165
5ED□B		842	697	145	267	482	322	532	75 ^{+0.030} _{+0.011}	140	2.5	185
3Z□□D	800	842	697	145	267	482	322	532	75 ^{+0.030} _{+0.011}	140	2.5	185
3G□□D		892	747	145	317	532	372	582	75 ^{+0.030} _{+0.011}	140	2.5	205
4ED□D		973	798	175	357	572	412	622	85 ^{+0.035} _{+0.013}	170	2.5	225

Note: Models with oil seals are of the same configuration.

· Cable Specifications for Encoder-end Connector

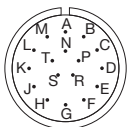

Receptacle : 97F3102E20-29P
L-shaped Plug : JA08A-20-29S-J1-EB (CE-compliant) or MS3108B20-29S
Straight Plug : JA06A-20-29S-J1-EB (CE-compliant) or MS3106B20-29S
Cable Clamp : JL04-2022CKE (***) (CE-compliant) or MS3057-12A

Note: 1 "***" gives the cable diameter.
2 For information on the cable models, refer to *Selecting Cables*.
3 To conform with CE Marking, plugs and cable clamps with CE Marking are required.

· Cable Specifications for Fan-end Connector

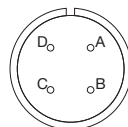

Receptacle : CE05-2A18-10PD-D
L-shaped Plug : CE05-8A18-10SD-D-BAS
Straight Plug : CE05-6A18-10SD-D-BSS
Cable Clamp : CE3057-10A-*(D265) (CE-compliant) or MS3057-10A

Note: 1 "*" gives the cable diameter.
2 To conform with CE Marking, plugs and cable clamps with CE Marking are required.

A	Fan terminal (U)
B	Fan terminal (V)
C	Fan terminal (W)
D	

With an Absolute Encoder

A	-	K	-
B	-	L	-
C	PS	M	-
D	/PS	N	-
E	-	P	-
F	-	R	-
G	PG 0V	S	BAT (-)
H	PG 5V	T	BAT (+)
J	FG (Frame ground)		

With an Incremental Encoder

A	-	K	-
B	-	L	-
C	PS	M	-
D	/PS	N	-
E	-	P	-
F	-	R	-
G	PG 0V	S	-
H	PG 5V	T	-
J	FG (Frame ground)		

· Terminal Box Details

U, V, W	Motor terminals	M10
⊕	Ground terminal	M10
1, 1b	Thermostat terminals	M4

Note: Always connect a thermostat to protect the servomotor from overheating.

External Dimensions Units: mm

● Flange-mounted Servomotors with Holding Brakes

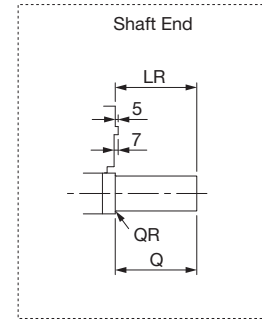
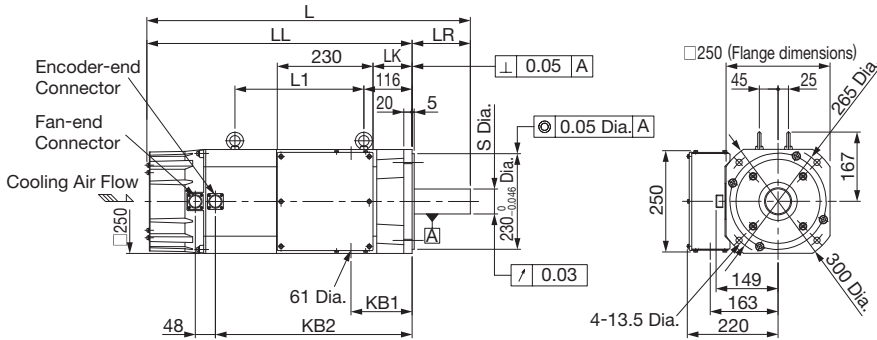

For the specifications of the other shaft ends, refer to page 19.

Servomotor Model SGMWV-	Rated Speed min ⁻¹	L	LL	LR	LK	L1	KB1	KB2	S Dia.	Q	QR	Approx. Mass kg
2B□□B	1500	778	638	140	94	310	147	473	60 ^{+0.030} / _{+0.011}	140	1.6	130
3Z□□B		824	684	140	140	356	193	519	60 ^{+0.030} / _{+0.011}	140	1.6	145
3G□□B		884	744	140	180	416	233	579	65 ^{+0.030} / _{+0.011}	140	1.2	155
2B□□D	800	934	794	140	230	466	283	629	65 ^{+0.030} / _{+0.011}	140	1.2	170

Note: Models with oil seals are of the same configuration.

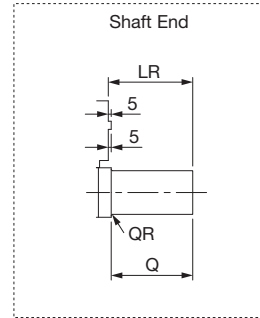
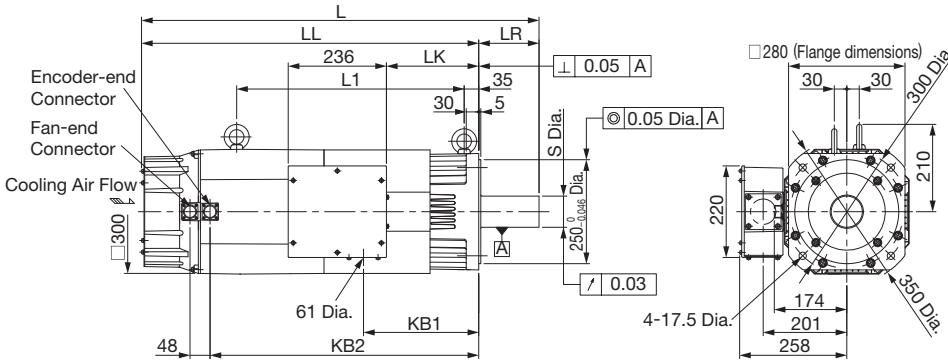

For the specifications of the other shaft ends, refer to page 19.

Servomotor Model SGMWV-	Rated Speed min ⁻¹	L	LL	LR	LK	L1	KB1	KB2	S Dia.	Q	QR	Approx. Mass kg
4ED□B	1500	956	811	145	222	547	277	646	75 ^{+0.030} / _{+0.011}	140	2.5	215

Note: Models with oil seals are of the same configuration.

· Cable Specifications for Encoder-end Connector

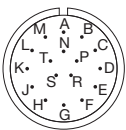

Receptacle : 97F3102E20-29P
 L-shaped Plug : JA08A-20-29S-J1-EB
 (CE-compliant) or MS3108B20-29S
 Straight Plug : JA06A-20-29S-J1-EB
 (CE-compliant) or MS3106B20-29S
 Cable Clamp : JL04-2022CKE (**)
 (CE-compliant) or MS3057-12A

Note: 1 "*" gives the cable diameter.
 2 For information on the cable models, refer to *Selecting Cables*.
 3 To conform with CE Marking, plugs and cable clamps with CE Marking are required.

· Cable Specifications for Fan-end Connector

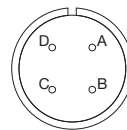

Receptacle : CE05-2A18-10PD-D
 L-shaped Plug : CE05-8A18-10SD-D-BAS
 Straight Plug : CE05-6A18-10SD-D-BSS
 Cable Clamp : CE3057-10A-*(D265)
 (CE-compliant) or MS3057-10A

Note: 1 "*" gives the cable diameter.
 2 To conform with CE Marking, plugs and cable clamps with CE Marking are required.

A	Fan terminal (U)
B	Fan terminal (V)
C	Fan terminal (W)
D	

With an Absolute Encoder

A	-	K	-
B	-	L	-
C	PS	M	-
D	/PS	N	-
E	-	P	-
F	-	R	-
G	PG 0V	S	BAT (-)
H	PG 5V	T	BAT (+)
J	FG (Frame ground)		

With an Incremental Encoder

A	-	K	-
B	-	L	-
C	PS	M	-
D	/PS	N	-
E	-	P	-
F	-	R	-
G	PG 0V	S	-
H	PG 5V	T	-
J	FG (Frame ground)		

· Terminal Box Details

U, V, W	Motor terminals	M10
⊕	Ground terminal	M10
1, 1b	Thermostat terminals	M4
A, B	Brake terminals	M4

Note: Always connect a thermostat to protect the servomotor from overheating.

External Dimensions Units: mm

● **Foot-mounted Servomotors without Holding Brakes**

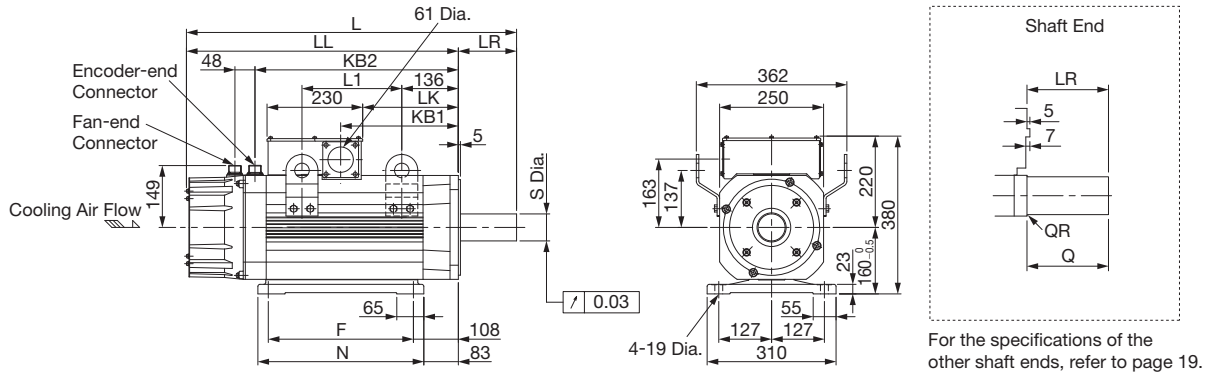

Servomotor Model SGMV-	Rated Speed min ⁻¹	L	LL	LR	LK	L1	KB1	KB2	F	N	S Dia.	Q	QR	Approx. Mass kg
2B□□B	1500	658	518	140	94	104	147	353	210	260	60 ^{+0.030} / _{+0.011}	140	1.6	110
3Z□□B		704	564	140	140	150	193	399	241	291	60 ^{+0.030} / _{+0.011}	140	1.6	125
3G□□B		744	604	140	180	190	233	439	279	329	65 ^{+0.030} / _{+0.011}	140	1.2	140
2B□□D	800	794	654	140	230	240	283	489	349	399	65 ^{+0.030} / _{+0.011}	140	1.2	155

Note: Models with oil seals are of the same configuration.

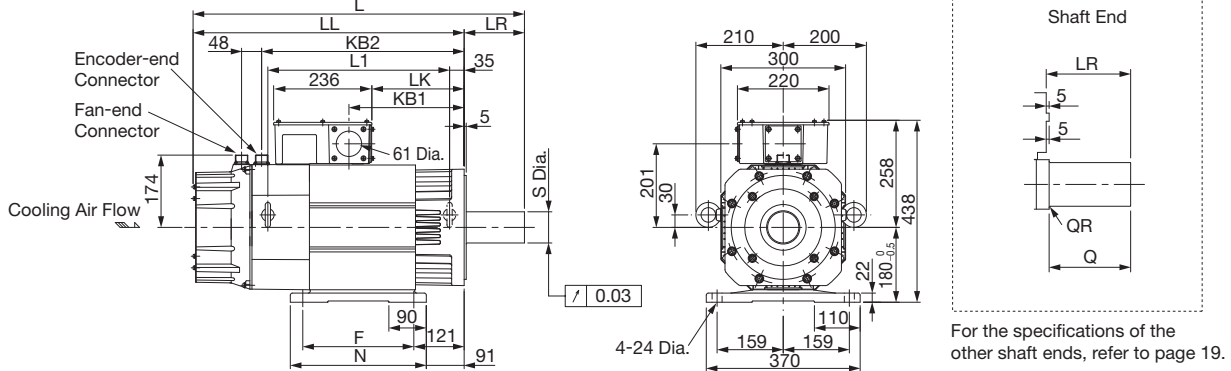

Servomotor Model SGMV-	Rated Speed min ⁻¹	L	LL	LR	LK	L1	KB1	KB2	F	N	S Dia.	Q	QR	Approx. Mass kg
4ED□B	1500	797	652	145	222	437	277	487	267	327	75 ^{+0.030} / _{+0.011}	140	2.5	180
5ED□B		842	697	145	267	482	322	532	311	371	75 ^{+0.030} / _{+0.011}	140	2.5	205
3Z□□D	800	842	697	145	267	482	322	532	311	371	75 ^{+0.030} / _{+0.011}	140	2.5	205
3G□□D		892	747	145	317	532	372	582	349	409	75 ^{+0.030} / _{+0.011}	140	2.5	230
4ED□D		973	798	175	357	572	412	622	368	428	85 ^{+0.035} / _{+0.013}	170	2.5	250

Note: Models with oil seals are of the same configuration.

· Cable Specifications for Encoder-end Connector

Receptacle : 97F3102E20-29P
 L-shaped Plug : JA08A-20-29S-J1-EB (CE-compliant) or MS3108B20-29S
 Straight Plug : JA06A-20-29S-J1-EB (CE-compliant) or MS3106B20-29S
 Cable Clamp : JL04-2022CKE (***) (CE-compliant) or MS3057-12A

Note: 1 "*" gives the cable diameter.
 2 For information on the cable models, refer to *Selecting Cables*.
 3 To conform with CE Marking, plugs and cable clamps with CE Marking are required.

· Cable Specifications for Fan-end Connector

Receptacle : CE05-2A18-10PD-D
 L-shaped Plug : CE05-8A18-10SD-D-BAS
 Straight Plug : CE05-6A18-10SD-D-BSS
 Cable Clamp : CE3057-10A-*(D265) (CE-compliant) or MS3057-10A

Note: 1 "*" gives the cable diameter.
 2 To conform with CE Marking, plugs and cable clamps with CE Marking are required.

A	Fan terminal (U)
B	Fan terminal (V)
C	Fan terminal (W)
D	

With an Absolute Encoder

A	-	K	-
B	-	L	-
C	PS	M	-
D	/PS	N	-
E	-	P	-
F	-	R	-
G	PG 0V	S	BAT (-)
H	PG 5V	T	BAT (+)
J	FG (Frame ground)		

With an Incremental Encoder

A	-	K	-
B	-	L	-
C	PS	M	-
D	/PS	N	-
E	-	P	-
F	-	R	-
G	PG 0V	S	-
H	PG 5V	T	-
J	FG (Frame ground)		

· Terminal Box Details

U, V, W	Motor terminals	M10
⊕	Ground terminal	M10
1, 1b	Thermostat terminals	M4

Note: Always connect a thermostat to protect the servomotor from overheating.

External Dimensions Units: mm

●Foot-mounted Servomotors with Holding Brakes

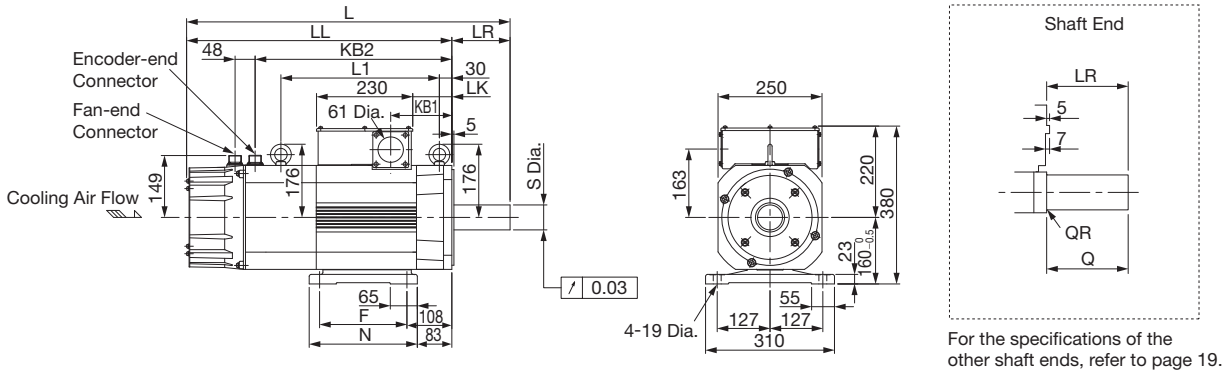

Servomotor Model SGMV-	Rated Speed min ⁻¹	L	LL	LR	LK	L1	KB1	KB2	F	N	S Dia.	Q	QR	Approx. Mass kg
2B□□B	1500	778	638	140	94	381	147	473	210	260	60 ^{+0.030} _{+0.011}	140	1.6	145
3Z□□B		824	684	140	140	427	193	519	241	291	60 ^{+0.030} _{+0.011}	140	1.6	160
3G□□B		884	744	140	180	487	233	579	279	329	65 ^{+0.030} _{+0.011}	140	1.2	175
2B□□D	800	934	794	140	230	537	283	629	349	399	65 ^{+0.030} _{+0.011}	140	1.2	190

Note: Models with oil seals are of the same configuration.

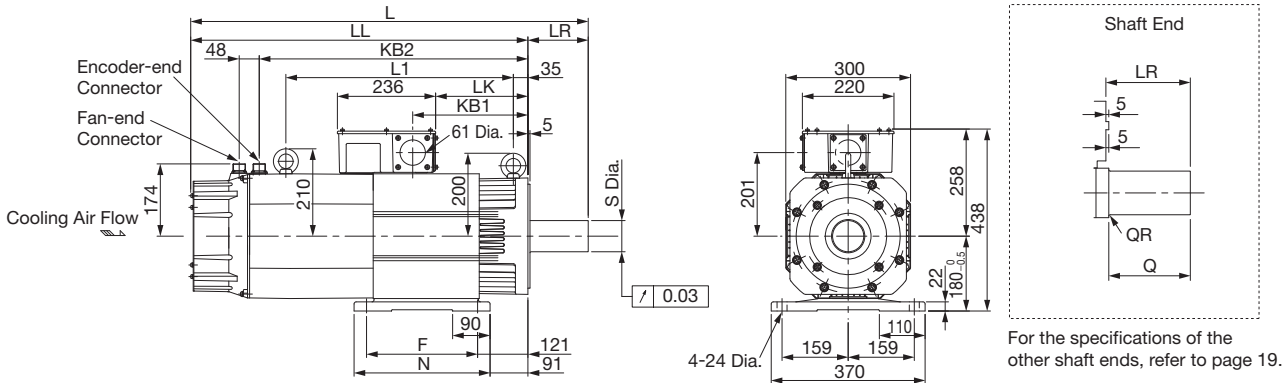

Servomotor Model SGMV-	Rated Speed min ⁻¹	L	LL	LR	LK	L1	KB1	KB2	F	N	S Dia.	Q	QR	Approx. Mass kg
4ED□B	1500	956	811	145	222	547	277	646	267	327	75 ^{+0.030} _{+0.011}	140	2.5	235
5ED□B		1001	856	145	267	592	322	691	311	371	75 ^{+0.030} _{+0.011}	140	2.5	260
3Z□□D	800	1001	856	145	267	592	322	691	311	371	75 ^{+0.030} _{+0.011}	140	2.5	260
3G□□D		1051	906	145	317	642	372	741	349	409	75 ^{+0.030} _{+0.011}	140	2.5	285

Note: Models with oil seals are of the same configuration.

· Cable Specifications for Encoder-end Connector

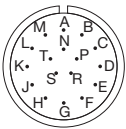

- Receptacle : 97F3102E20-29P
- L-shaped Plug : JA08A-20-29S-J1-EB (CE-compliant) or MS3108B20-29S
- Straight Plug : JA06A-20-29S-J1-EB (CE-compliant) or MS3106B20-29S
- Cable Clamp : JL04-2022CKE (**)

Note: 1 "*" gives the cable diameter.
 2 For information on the cable models, refer to *Selecting Cables*.
 3 To conform with CE Marking, plugs and cable clamps with CE Marking are required.

· Cable Specifications for Fan-end Connector

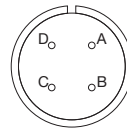

- Receptacle : CE05-2A18-10PD-D
- L-shaped Plug : CE05-8A18-10SD-D-BAS
- Straight Plug : CE05-6A18-10SD-D-BSS
- Cable Clamp : CE3057-10A-*(D265) (CE-compliant) or MS3057-10A

Note: 1 "*" gives the cable diameter.
 2 To conform with CE Marking, plugs and cable clamps with CE Marking are required.

A	Fan terminal (U)
B	Fan terminal (V)
C	Fan terminal (W)
D	

With an Absolute Encoder

A	-	K	-
B	-	L	-
C	PS	M	-
D	/PS	N	-
E	-	P	-
F	-	R	-
G	PG 0V	S	BAT (-)
H	PG 5V	T	BAT (+)
J	FG (Frame ground)		

With an Incremental Encoder

A	-	K	-
B	-	L	-
C	PS	M	-
D	/PS	N	-
E	-	P	-
F	-	R	-
G	PG 0V	S	-
H	PG 5V	T	-
J	FG (Frame ground)		

· Terminal Box Details

U, V, W	Motor terminals	M10
⊕	Ground terminal	M10
1, 1b	Thermostat terminals	M4
A, B	Brake terminals	M4

Note: Always connect a thermostat to protect the servomotor from overheating.

External Dimensions Units: mm

● Shaft End

SGMVV - □□□□□□□□

Code	Specifications	Remarks
2	Flange-mounted with straight shaft end (without key and no tap)	Standard
6	Flange-mounted with straight shaft end (with key and tap)	Optional
K	Foot-mounted with straight shaft end (without key and no tap)	Standard
L	Foot-mounted with straight shaft end (with key and tap)	Optional

Code	Specifications	Shaft End	Servomotor Model SGMVV-									
			2BA□B	3ZA□B	3GA□B	—	—	2BA□D	3ZA□D	3GA□D	—	
			2BD□B	3ZD□B	3GD□B	4ED□B	5ED□B	2BD□D	3ZD□D	3GD□D	4ED□D	
2. K	Straight without Key		LR	140	140	140	145	145	140	145	145	175
			Q	140	140	140	140	140	140	140	140	170
			QR	1.6	1.6	1.2	2.5	2.5	1.2	2.5	2.5	2.5
			S	60 ^{+0.030} / _{-0.011}	60 ^{+0.030} / _{-0.011}	65 ^{+0.030} / _{-0.011}	75 ^{+0.030} / _{-0.011}	75 ^{+0.030} / _{-0.011}	65 ^{+0.030} / _{-0.011}	75 ^{+0.030} / _{-0.011}	75 ^{+0.030} / _{-0.011}	85 ^{+0.035} / _{-0.013}
6. L	Straight with Key and Tap		LR	140	140	140	145	145	140	145	145	175
			Q	140	140	140	140	140	140	140	140	170
			QR	1.6	1.6	1.2	2.5	2.5	1.2	2.5	2.5	2.5
			QK	110	110	110	110	110	110	110	110	140
			S	60 ^{+0.030} / _{-0.011}	60 ^{+0.030} / _{-0.011}	65 ^{+0.030} / _{-0.011}	75 ^{+0.030} / _{-0.011}	75 ^{+0.030} / _{-0.011}	65 ^{+0.030} / _{-0.011}	75 ^{+0.030} / _{-0.011}	75 ^{+0.030} / _{-0.011}	85 ^{+0.035} / _{-0.013}
			W	18	18	18	20	20	18	20	20	22
			T	11	11	11	12	12	11	12	12	14
			U	7	7	7	7.5	7.5	7	7.5	7.5	9
P	M20 Screw, Depth40											

SERVOPACKs Analog Voltage/Pulse Train Ref. Type

Ratings

Three-phase 200 V

SERVOPACK Model: SGD V-□□□□		121H	161H	201H
Applicable Servomotor Max.Capacity kW		22	30	37
Continuous Output Current Arms		116	160	200
Max. Output Current Arms		240	340	460
Input Power	Main Circuit P/N	270 to 310 VDC		
	Control Circuit	24 VDC ± 15%		

Three-phase 400 V

SERVOPACK Model: SGD V-□□□□		750J	101J	131J
Applicable Servomotor Max.Capacity kW		30	37	55
Continuous Output Current Arms		75	98	130
Max. Output Current Arms		170	230	340
Input Power	Main Circuit P/N	520 to 650 VDC		
	Control Circuit	24 VDC ± 15%		

Note: Refer to page 5 for combinations with converters.

●SERVOPACK Overload Characteristics

The overload detection level is set under hot start conditions at a servomotor ambient temperature of 40°C.

Motors with Rated Speed of 1,500 min⁻¹

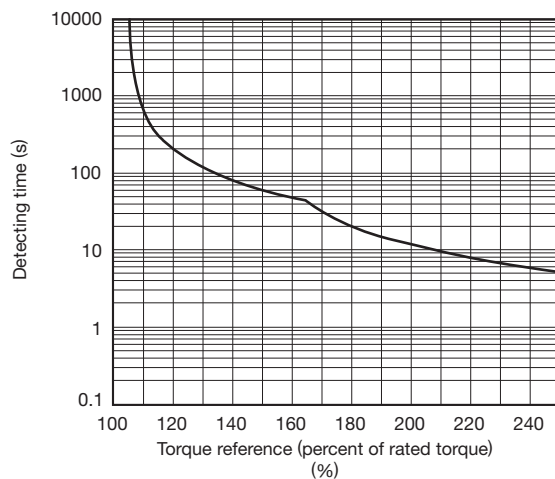

Motors with Rated Speed of 800 min⁻¹

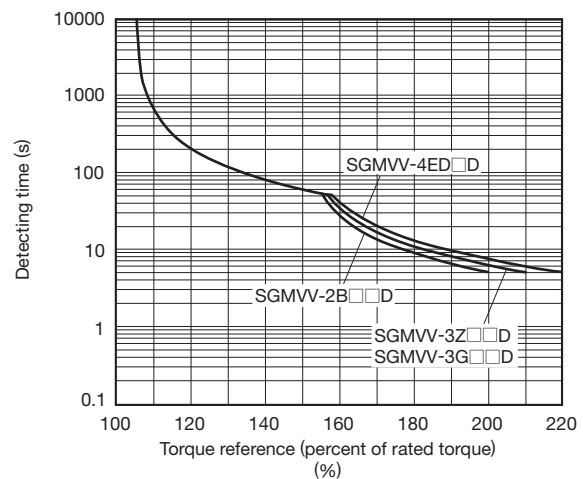

Note: Overload characteristics shown above do not guarantee continuous duty of 100% or more output.
Use a servomotor with effective torque within the continuous duty zone of *Torque-Motor Speed Characteristics*.

Specifications

● Basic Specifications

Items		Specifications		
Drive Method		Sine-wave current drive with PWM control of IGBT		
Feedback		Encoder: 20-bit (incremental, absolute)		
Operating Conditions	Surrounding Air Temperature	0°C to +55°C		
	Storage Temperature	-20°C to +85°C		
	Ambient Humidity	90%RH or less	With no freezing or condensation	
	Storage Humidity	90%RH or less		
	Vibration Resistance	4.9 m/s ²		
	Shock Resistance	19.6 m/s ²		
	Protection Class	IP10	An environment that satisfies the following conditions. · Free of corrosive or flammable gases · Free of exposure to water, oil, or chemicals · Free of dust, salts, or iron dust	
	Pollution Degree	2		
	Altitude	1000 m or less		
Others	Free of static electricity, strong electromagnetic fields, magnetic fields or exposure to radioactivity			
Overvoltage Category		III		
Harmonized Standards (Application pending)		UL508C EN50178, EN55011 group 1 class A, EN61000-6-2, EN61800-3, EN61800-5-1, EN954-1, IEC61508-1 to 4		
Mounting		Standard: Base-mounted Optional: Duct-ventilated		
Performance	Speed Control Range		1:5000 (The lower limit of the speed control range must be lower than the point at which the rated torque does not cause the servomotor to stop.)	
	Speed Regulation*1	Load Regulation	0% to 100% load: ±0.01% max. (at rated speed)	
		Voltage Regulation	Rated voltage: ±10% : 0% (at rated speed)	
		Temperature Regulation	25±25°C : ±0.1% max. (at rated speed)	
	Torque Control Tolerance (Repeatability)		±1%	
Soft Start Time Setting		0 to 10 s (can be set individually for acceleration and deceleration.)		
I/O Signals	Encoder Output Pulses		Phase A, phase B, phase C: line driver output The number of dividing pulse: Any setting ratio is available.	
	Sequence Input	Fixed Input	SEN signal	
		Input Signals which can be allocated	Number of Channels	7 channels
	Functions		<ul style="list-style-type: none"> · Servo ON (/S-ON) · Proportional control (/P-CON) · Forward run prohibited (P-OT), reverse run prohibited (N-OT) · Alarm reset (/ALM-RST) · Forward external torque limit (/P-CL), reverse external torque limit (/N-CL) · Internal set speed control (/SPD-D, /SPD-A, /SPD-B) Signal allocations can be performed, and positive and negative logic can be changed.	
	Control selection (/C-SEL)		<ul style="list-style-type: none"> · Zero clamping (/ZCLAMP) · Reference pulse inhibit (/INHIBIT) · Gain selection (/G-SEL) · Reference pulse input multiplication switching (/PSEL) · DB answer (/DBANS) 	
	Sequence Output		Fixed Output	Servo alarm (ALM), alarm code (ALO1, ALO2, ALO3) outputs
Output Signals which can be allocated	Number of Channels	3 channels		
	Functions	<ul style="list-style-type: none"> · Positioning completion (/COIN) · Speed coincidence detection (/W-CMP) · Rotation detection (/TGON) · Servo ready (/S-RDY) · Torque limit detection (/CLT) · Speed limit detection (/VLT) Signal allocations can be performed, and positive and negative logic can be changed.		
Communications	RS-422A Communications (CN3)	Interface	Digital operator (JUSP-OP05A-1-E), personal computer (can be connected with SigmaWin+)	
		1:N Communications	N = Up to 15 stations possible at RS-422A	
	USB Communications (CN7)	Axis Address Setting	Set by parameters	
		Interface	Personal computer (can be connected with SigmaWin+.)	
LED Display		CHARGE indicator		
Communications Standard		Complies with standard USB1.1. (12 Mbps)		

Specifications

● Basic Specifications (Cont'd)

Items		Specifications
Panel Operator	Display Unit	Five 7-segment LEDs
	Switch	Four push switches
Analog Monitor (CN5)		Number of points: 2 Output voltage: ±10 VDC (linearity effective range ±8 V) Resolution: 16 bits Accuracy: ±20 mV (Typ) Max. output current: ±10 mA Settling time (±1%): 1.2 ms (Typ)
Dynamic Brake (DB)		Included An external Dynamic Brake Unit is required. For information on the recommended Dynamic Brake Unit, refer to <i>Dynamic Brake Unit</i> on page 81.
Regenerative Processing		Included An external regenerative resistor is required. For information on the recommended regenerative resistor, refer to <i>Regenerative Resistor</i> on page 79.
Overtravelling (OT) Prevention		Dynamic brake stop, deceleration to a stop, or free run to a stop at P-OT or N-OT
Protective Functions		Overcurrent, overvoltage, insufficient voltage, overload, regeneration error, etc.
Utility Functions		Gain adjustment, alarm history, JOG operation, origin search, etc.
Safety Functions	Input	/HWBB1, /HWBB2: Baseblock signal for power module
	Output	EDM1: Monitoring status of internal safety circuit (fixed output)
	Standards*2 (Application pending)	EN954 Category 3, IEC61508 SIL2
Option Module*3		Fully-closed module, safety module

*1 : Speed regulation by load regulation is defined as follows:

$$\text{Speed regulation} = \frac{\text{No-load motor speed} - \text{Total load motor speed}}{\text{Rated motor speed}} \times 100\%$$

*2 : Implement risk assessment and confirm that the safety requirements of the machine have been met.

*3 : Refer to page 42 for combinations with modules.

● Speed/Position/Torque Control Specifications

Control Method		Specifications		
Speed Control	Soft Start Time Setting		0 to 10 s (can be set individually for acceleration and deceleration.)	
	Input Signals	Reference Voltage	· Max. input voltage: ±12 V (forward speed reference with positive reference) · Factory setting: 6 VDC at rated speed (Input gain setting can be changed.)	
		Input Impedance	Approx. 14 kΩ	
		Circuit Time Constant	30 μs	
	Internal Set Speed Control	Rotation Direction Selection	With P control signal	
		Speed Selection	With forward/reverse external torque limit signal (speed 1 to 3 selection). Servomotor stops or another control method is used when both are OFF.	
Position Control	Feedforward Compensation		0 to 100%	
	Positioning Completed Width Setting		0 to 1073741824 reference units	
	Input Signals	Reference Pulse	Type	Select one of them: Sign + pulse train, CW + CCW pulse train, or two-phase pulse train with 90° phase differential
			Form	For line driver, open collector
		Max. Input Pulse Frequency	Line driver	Sign + pulse train, CW + CCW pulse train: 4 Mpps Two-phase pulse train with 90° phase differential: 1 Mpps
			Open collector	Sign + pulse train, CW + CCW pulse train: 200 kpps Two-phase pulse train with 90° phase differential: 200 kpps
	Reference Pulse Input Multiplication Switching		1 to 100 times	
	Clear Signal		Position error clear For line driver, open collector	
Torque Control	Input Signals	Reference Voltage	· Max. input voltage: ±12 V (forward torque reference with positive reference) · Factory setting: 3 VDC at rated torque (Input gain setting can be changed.)	
		Input Impedance	Approx. 14 kΩ	
		Circuit Time Constant	16 μs	

Power Supply Capacities and Power Losses

The following table shows SERVOPACK's power supply capacities and power losses at the rated output.

Main Circuit Power Supply Voltage	Applicable Servomotor Max. Capacity kW	Combination of SERVOPACK and Converter		Power Supply Capacity for Each SERVOPACK-Converter Set kVA	Output Current Arms	Main Circuit Power Loss W	Regenerative Resistor Power Loss W	Control Circuit Power Loss W	Total Power Loss W
		SERVOPACK Model SGD V-	Converter Model SGD V-COA						
Three-phase 200 V	22	121H	2BAA	38	116	1200	(480) *1	120	1320
	30	161H	3GAA	52	160	1540	(960) *2	120	1660
	37	201H	3GAA	64	200	1540	(960) *3	120	1660
Three-phase 400 V	30	750J	3ZDA	52	76	1020	(720) *4	96	1116
	37	101J	5EDA	64	98	1240	(960) *5	96	1336
	55	131J	5EDA	95	130	1590	(1440) *6	96	1686

*1 : For the optional JUSP-RA08-E regenerative resistor.

*2 : For the optional JUSP-RA09-E regenerative resistor.

*3 : For the optional JUSP-RA11-E regenerative resistor.

*4 : For the optional JUSP-RA13-E regenerative resistor.

*5 : For the optional JUSP-RA14-E regenerative resistor.

*6 : For the optional JUSP-RA16-E regenerative resistor.

Ratings

Three-phase 200 V

SERVOPACK Model: SGD V-□□□□		121H	161H	201H
Applicable Servomotor Max.Capacity kW		22	30	37
Continuous Output Current Arms		116	160	200
Max. Output Current Arms		240	340	460
Input Power	Main Circuit P/N	270 to 310 VDC		
	Control Circuit	24 VDC ± 15%		

Three-phase 400 V

SERVOPACK Model: SGD V-□□□□		750J	101J	131J
Applicable Servomotor Max.Capacity kW		30	37	55
Continuous Output Current Arms		75	98	130
Max. Output Current Arms		170	230	340
Input Power	Main Circuit P/N	520 to 650 VDC		
	Control Circuit	24 VDC ± 15%		

Note: Refer to page 5 for combinations with converters.

● SERVOPACK Overload Characteristics

The overload detection level is set under hot start conditions at a servomotor ambient temperature of 40°C.

Motors with Rated Speed of 1,500 min⁻¹

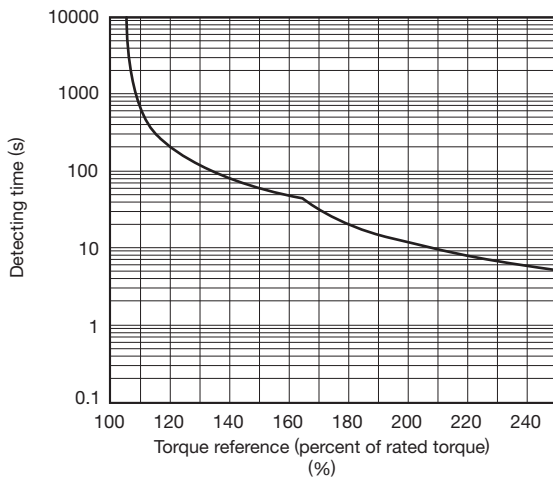

Motors with Rated Speed of 800 min⁻¹

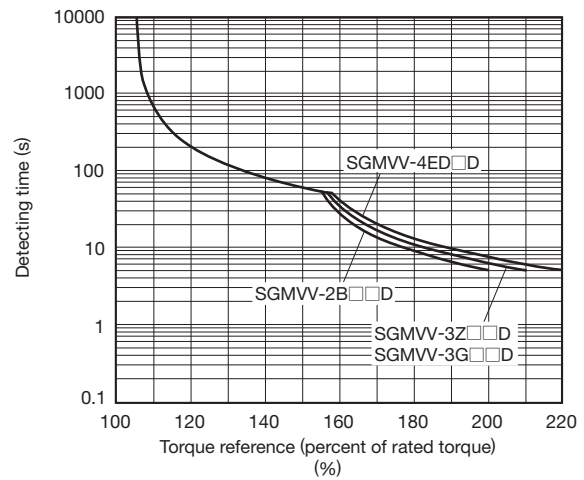

Note: Overload characteristics shown above do not guarantee continuous duty of 100% or more output. Use a servomotor with effective torque within the continuous duty zone of *Torque-Motor Speed Characteristics*.

Specifications

● Basic Specifications

Items		Specifications		
Drive Method		Sine-wave current drive with PWM control of IGBT		
Feedback		Encoder: 20-bit (incremental, absolute)		
Operating Conditions	Surrounding Air Temperature	0°C to +55°C		
	Storage Temperature	-20°C to +85°C		
	Ambient Humidity	90%RH or less	With no freezing or condensation	
	Storage Humidity	90%RH or less		
	Vibration Resistance	4.9 m/s ²		
	Shock Resistance	19.6 m/s ²		
	Protection Class	IP10	An environment that satisfies the following conditions. <ul style="list-style-type: none"> Free of corrosive or flammable gases Free of exposure to water, oil, or chemicals Free of dust, salts, or iron dust 	
	Pollution Degree	2		
	Altitude	1000 m or less		
Others	Free of static electricity, strong electromagnetic fields, magnetic fields or exposure to radioactivity			
Overvoltage Category		III		
Harmonized Standards (Application pending)		UL508C EN50178, EN55011 group 1 class A, EN61000-6-2, EN61800-3, EN61800-5-1, EN954-1, IEC61508-1 to 4		
Mounting		Standard: Base-mounted Optional: Duct-ventilated		
Performance	Speed Control Range		1:5000 (The lower limit of the speed control range must be lower than the point at which the rated torque does not cause the servomotor to stop.)	
	Speed Regulation*1	Load Regulation	0% to 100% load: ±0.01% max. (at rated speed)	
		Voltage Regulation	Rated voltage: ±10% : 0% (at rated speed)	
		Temperature Regulation	25±25°C : ±0.1% max. (at rated speed)	
	Torque Control Tolerance (Repeatability)		±1%	
Soft Start Time Setting		0 to 10 s (can be set individually for acceleration and deceleration.)		
I/O Signals	Encoder Output Pulses		Phase A, phase B, phase C: line driver output The number of dividing pulse: Any setting ratio is available.	
	Sequence Input	Input Signals which can be allocated	Number of Channels	7 channels
			Function	<ul style="list-style-type: none"> Homing deceleration switch signal (/DEC) Forward external torque limit (/P-CL), reverse external torque limit (/N-CL) reverse run prohibited (/N-OT) DB answer (/DBANS) External latch signals (/EXT 1 to 3) Signal allocations can be performed, and positive and negative logic can be changed.
	Sequence Output	Output Signals which can be allocated	Fixed Output	Servo alarm (ALM)
Number of Channels			3 channels	
Function	<ul style="list-style-type: none"> Positioning completion (/COIN) Speed limit detection (/VLT) Speed coincidence detection (/V-CMP) Brake (/BK) Warning (/WARN) Rotation detection (/TGON) Near (/NEAR) Servo ready (/S-RDY) Torque limit detection (/CLT) Signal allocations can be performed, and positive and negative logic can be changed.			
Communications	RS-422A Communications (CN3)	Interface	Digital operator (JUSP-OP05A-1-E), personal computer (can be connected with SigmaWin+)	
		1:N Communications	N = Up to 15 stations possible at RS-422A	
		Axis Address Setting	Set by parameters	
	USB Communications (CN7)	Interface	Personal computer (can be connected with SigmaWin+.)	
Communications Standard		Complies with standard USB1.1. (12 Mbps)		
LED Display		Panel display (seven-segment), CHARGE, POWER, and COM indicators, one 7-segment LED		
MECHATROLINK-II Communications Setting Switches		Rotary Switch (S2)	Position: 16 positions	
		DIP Switch (S3)	Number of pins: Four pins	

Specifications

● Basic Specifications (Cont'd)

Items	Specifications	
Analog Monitor (CN5)	Number of points: 2 Output voltage: ± 10 VDC (linearity effective range ± 8 V) Resolution: 16 bits Accuracy: ± 20 mV (Typ) Max. output current: ± 10 mA Settling time ($\pm 1\%$): 1.2 ms (Typ)	
Dynamic Brake (DB)	Included An external Dynamic Brake Unit is required. For information on the recommended Dynamic Brake Unit, refer to <i>Dynamic Brake Unit</i> on page 81.	
Regenerative Processing	Included An external regenerative resistor is required. For information on the recommended regenerative resistor, refer to <i>Regenerative Resistor</i> on page 79.	
Overtravelling (OT) Prevention	Dynamic brake stop, deceleration to a stop, or free run to a stop at P-OT or N-OT	
Protective Functions	Overcurrent, overvoltage, insufficient voltage, overload, regeneration error, etc.	
Utility Functions	Gain adjustment, alarm history, JOG operation, origin search, etc.	
Safety Functions	Input	/HWBB1, /HWBB2: Baseblock signal for power module
	Output	EDM1: Monitoring status of internal safety circuit (fixed output)
	Standards*2 (Application pending)	EN954 Category 3, IEC61508 SIL2
Option Module*3	Fully-closed module, safety module	

*1 : Speed regulation by load regulation is defined as follows:

$$\text{Speed regulation} = \frac{\text{No-load motor speed} - \text{Total load motor speed}}{\text{Rated motor speed}} \times 100\%$$

*2 : Implement risk assessment and confirm that the safety requirements of the machine have been met.

*3 : Refer to page 42 for combinations with modules.

● MECHATROLINK-II Function Specifications

Function	Specifications	
MECHATROLINK-II Communication	Communication Protocol	MECHATROLINK-II
	Baud Rate	10 Mbps, 4 Mbps Can be selected by the DIP switch (S3).
	Transmission Cycle	250 μ s, 0.5 ms to 4.0 ms (Multiples of 0.5 ms)
	Number of Transmission Bytes	17 bytes per station or 32 bytes per station Can be selected by the DIP switch (S3).
	Station Address	41H to 5FH (Max. number of stations: 30) Can be selected by the combination of the rotary switch (S2) and the DIP switch (S3).
Reference Method	Control Method	Position, speed, or torque control with MECHATROLINK-II communication
	Reference Input	MECHATROLINK-I, MECHATROLINK-II commands (sequence, motion, data setting/reference, monitoring, or adjustment)

Power Supply Capacities and Power Losses

The following table shows SERVOPACK's power supply capacities and power losses at the rated output.

Main Circuit Power Supply Voltage	Applicable Servomotor Max. Capacity kW	Combination of SERVOPACK and Converter		Power Supply Capacity for Each SERVOPACK-Converter Set kVA	Output Current Arms	Main Circuit Power Loss W	Regenerative Resistor Power Loss W	Control Circuit Power Loss W	Total Power Loss W
		SERVOPACK Model SGD V-	Converter Model SGD V-COA						
Three-phase 200 V	22	121H	2BAA	38	116	1200	(480) *1	120	1320
	30	161H	3GAA	52	160	1540	(960) *2	120	1660
	37	201H	3GAA	64	200	1540	(960) *3	120	1660
Three-phase 400 V	30	750J	3ZDA	52	76	1020	(720) *4	96	1116
	37	101J	5EDA	64	98	1240	(960) *5	96	1336
	55	131J	5EDA	95	130	1590	(1440) *6	96	1686

*1 : For the optional JUSP-RA08-E regenerative resistor.

*2 : For the optional JUSP-RA09-E regenerative resistor.

*3 : For the optional JUSP-RA11-E regenerative resistor.

*4 : For the optional JUSP-RA13-E regenerative resistor.

*5 : For the optional JUSP-RA14-E regenerative resistor.

*6 : For the optional JUSP-RA16-E regenerative resistor.

Ratings

Three-phase 200 V

SERVOPACK Model: SGD□-□□□□		121H	161H	201H
Applicable Servomotor Max.Capacity kW		22	30	37
Continuous Output Current Arms		116	160	200
Max. Output Current Arms		240	340	460
Input Power	Main Circuit P/N	270 to 310 VDC		
	Control Circuit	24 VDC ± 15%		

Three-phase 400 V

SERVOPACK Model: SGD□-□□□□		750J	101J	131J
Applicable Servomotor Max.Capacity kW		30	37	55
Continuous Output Current Arms		75	98	130
Max. Output Current Arms		170	230	340
Input Power	Main Circuit P/N	520 to 650 VDC		
	Control Circuit	24 VDC ± 15%		

Note: Refer to page 5 for combinations with converters.

●SERVOPACK Overload Characteristics

The overload detection level is set under hot start conditions at a servomotor ambient temperature of 40°C.

Motors with Rated Speed of 1,500 min⁻¹

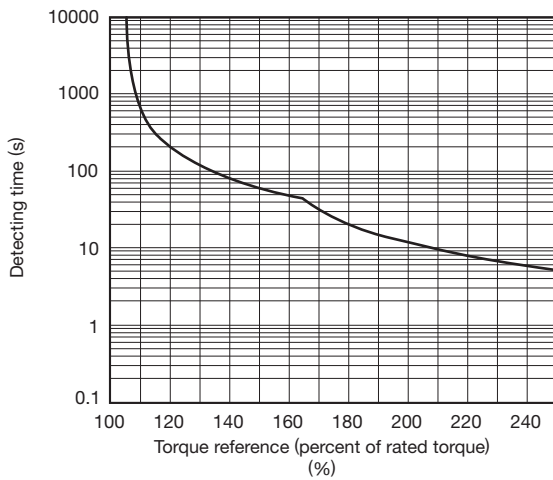

Motors with Rated Speed of 800 min⁻¹

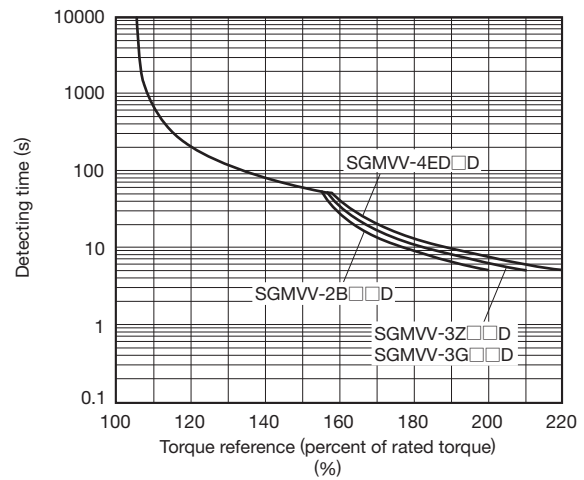

Note: Overload characteristics shown above do not guarantee continuous duty of 100% or more output.
Use a servomotor with effective torque within the continuous duty zone of *Torque-Motor Speed Characteristics*.

Specifications

● Basic Specifications

Items		Specifications		
Drive Method		Sine-wave current drive with PWM control of IGBT		
Feedback		Encoder: 20-bit (incremental, absolute)		
Operating Conditions	Surrounding Air Temperature	0°C to +55°C		
	Storage Temperature	-20°C to +85°C		
	Ambient Humidity	90%RH or less	With no freezing or condensation	
	Storage Humidity	90%RH or less		
	Vibration Resistance	4.9 m/s ²		
	Shock Resistance	19.6 m/s ²		
	Protection Class	IP10	An environment that satisfies the following conditions. · Free of corrosive or flammable gases · Free of exposure to water, oil, or chemicals · Free of dust, salts, or iron dust	
	Pollution Degree	2		
	Altitude	1000 m or less		
Others	Free of static electricity, strong electromagnetic fields, magnetic fields or exposure to radioactivity			
Overvoltage Category		III		
Harmonized Standards (Application pending)		UL508C EN50178, EN55011 group 1 class A, EN61000-6-2, EN61800-3, EN61800-5-1, EN954-1, IEC61508-1 to 4		
Mounting		Standard: Base-mounted Optional: Duct-ventilated		
Performance	Speed Control Range	1:5000 (The lower limit of the speed control range must be lower than the point at which the rated torque does not cause the servomotor to stop.)		
	Speed Regulation*1	Load Regulation	0% to 100% load: ±0.01% max. (at rated speed)	
		Voltage Regulation	Rated voltage: ±10% : 0% (at rated speed)	
		Temperature Regulation	25±25°C : ±0.1% max. (at rated speed)	
	Torque Control Tolerance (Repeatability)	±1%		
Soft Start Time Setting	0 to 10 s (can be set individually for acceleration and deceleration.)			
I/O Signals	Encoder Output Pulses		Phase A, phase B, phase C: line driver output The number of dividing pulse: Any setting ratio is available.	
	Sequence Input	Input Signals which can be allocated	Number of Channels 7 channels	
		Function	· Homing deceleration switch signal (/DEC) · Forward run prohibited (P-OT), reverse run prohibited (N-OT) · External latch signals (/EXT 1 to 3) Signal allocations can be performed, and positive and negative logic can be changed.	
	Sequence Output	Fixed Output	Servo alarm (ALM)	
Output Signals which can be allocated		Number of Channels 3 channels		
Function	· Positioning completion (/COIN) · Speed coincidence detection (/V-CMP) · Rotation detection (/TGON) · Servo ready (/S-RDY) · Torque limit detection (/CLT) Signal allocations can be performed, and positive and negative logic can be changed.	· Speed limit detection (/VLT) · Brake (/BK) · Warning (/WARN) · Near (/NEAR)		
Communications	RS-422A Communications (CN3)	Interface	Digital operator (JUSP-OP05A-1-E), personal computer (can be connected with SigmaWin+)	
		1:N Communications	N = Up to 15 stations possible at RS-422A	
		Axis Address Setting	Set by parameters	
	USB Communications (CN7)	Interface	Personal computer (can be connected with SigmaWin+.)	
Communications Standard		Complies with standard USB1.1. (12 Mbps)		
LED Display		Panel display (seven-segment), CHARGE, POWER, L1, L2, and CN indicators, one 7-segment LED		
MECHATROLINK-III Communications Setting Switches		Rotary Switches (S1 and S2)	Positions: 16 positions × 2 switches	
		DIP Switch (S3)	Number of pins: Four pins	

Specifications

● Basic Specifications (Cont'd)

Items		Specifications
Analog Monitor (CN5)		Number of points: 2 Output voltage: ±10 VDC (linearity effective range ±8 V) Resolution: 16 bits Accuracy: ±20 mV (Typ) Max. output current: ±10 mA Settling time (±1%): 1.2 ms (Typ)
Dynamic Brake (DB)		Included An external Dynamic Brake Unit is required. For information on the recommended Dynamic Brake Unit, refer to <i>Dynamic Brake Unit</i> on page 81.
Regenerative Processing		Included An external regenerative resistor is required. For information on the recommended regenerative resistor, refer to <i>Regenerative Resistor</i> on page 79.
Overtravelling (OT) Prevention		Dynamic brake stop, deceleration to a stop, or free run to a stop at P-OT or N-OT
Protective Functions		Overcurrent, overvoltage, insufficient voltage, overload, regeneration error, etc.
Utility Functions		Gain adjustment, alarm history, JOG operation, origin search, etc.
Safety Functions	Input	/HWBB1, /HWBB2: Baseblock signal for power module
	Output	EDM1: Monitoring status of internal safety circuit (fixed output)
	Standards*2 (Application pending)	EN954 Category 3, IEC61508 SIL2
Option Module*3		Fully-closed module, safety module

*1 : Speed regulation by load regulation is defined as follows:

$$\text{Speed regulation} = \frac{\text{No-load motor speed} - \text{Total load motor speed}}{\text{Rated motor speed}} \times 100\%$$

*2 : Implement risk assessment and confirm that the safety requirements of the machine have been met.

*3 : Refer to page 42 for combinations with modules.

● MECHATROLINK-III Function Specifications

Items		Specifications
MECHATROLINK-III Communication	Communications Protocol	MECHATROLINK-III
	Baud Rate	100 Mbps
	Transmission Cycle	125 μs, 250 μs, 500 μs, 750 μs, and 1 ms to 4 ms (increments of 0.5 ms)
	Number of Transmission Bytes	16, 32, or 48 bytes per station Use the DIP switch S3 to select the number of words.
	Station Address	03H to EFH (max. number of stations: 62) Use the rotary switches S1 and S2 to set the station address.
Reference Method	Control Method	Position, speed, or torque control with MECHATROLINK-III communication
	Reference Input	MECHATROLINK commands (sequence, motion, data setting/reference, monitoring, or adjustment)
	Profile	MECHATROLINK-III standard servo profile MECHATROLINK-II compatible profile

Power Supply Capacities and Power Losses

The following table shows SERVOPACK's power supply capacities and power losses at the rated output.

Main Circuit Power Supply Voltage	Applicable Servomotor Max. Capacity kW	Combination of SERVOPACK and Converter		Power Supply Capacity for Each SERVOPACK-Converter Set kVA	Output Current Arms	Main Circuit Power Loss W	Regenerative Resistor Power Loss W	Control Circuit Power Loss W	Total Power Loss W
		SERVOPACK Model SGD V-	Converter Model SGD V-COA						
Three-phase 200 V	22	121H	2BAA	38	116	1200	(480) *1	120	1320
	30	161H	3GAA	52	160	1540	(960) *2	120	1660
	37	201H	3GAA	64	200	1540	(960) *3	120	1660
Three-phase 400 V	30	750J	3ZDA	52	76	1020	(720) *4	96	1116
	37	101J	5EDA	64	98	1240	(960) *5	96	1336
	55	131J	5EDA	95	130	1590	(1440) *6	96	1686

*1 : For the optional JUSP-RA08-E regenerative resistor.

*2 : For the optional JUSP-RA09-E regenerative resistor.

*3 : For the optional JUSP-RA11-E regenerative resistor.

*4 : For the optional JUSP-RA13-E regenerative resistor.

*5 : For the optional JUSP-RA14-E regenerative resistor.

*6 : For the optional JUSP-RA16-E regenerative resistor.

Ratings

Three-phase 200 V

SERVOPACK Model: SGD V-□□□□		121H	161H	201H
Applicable Servomotor Max.Capacity kW		22	30	37
Continuous Output Current Arms		116	160	200
Max. Output Current Arms		240	340	460
Input Power	Main Circuit P/N	270 to 310 VDC		
	Control Circuit	24 VDC ± 15%		

Three-phase 400 V

SERVOPACK Model: SGD V-□□□□		750J	101J	131J
Applicable Servomotor Max.Capacity kW		30	37	55
Continuous Output Current Arms		75	98	130
Max. Output Current Arms		170	230	340
Input Power	Main Circuit P/N	520 to 650 VDC		
	Control Circuit	24 VDC ± 15%		

Note: Refer to page 5 for combinations with converters.

●SERVOPACK Overload Characteristics

The overload detection level is set under hot start conditions at a servomotor ambient temperature of 40°C.

Motors with Rated Speed of 1,500 min⁻¹

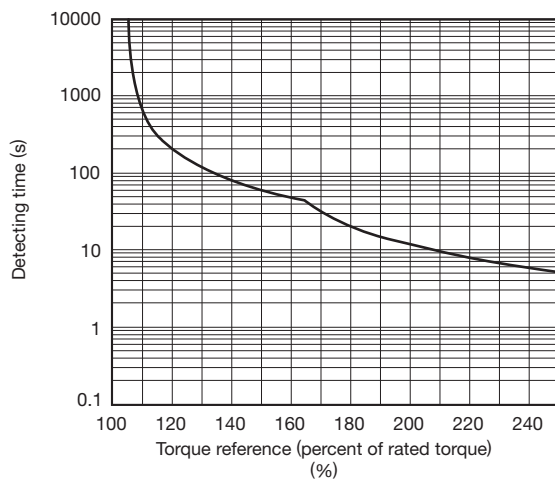

Motors with Rated Speed of 800 min⁻¹

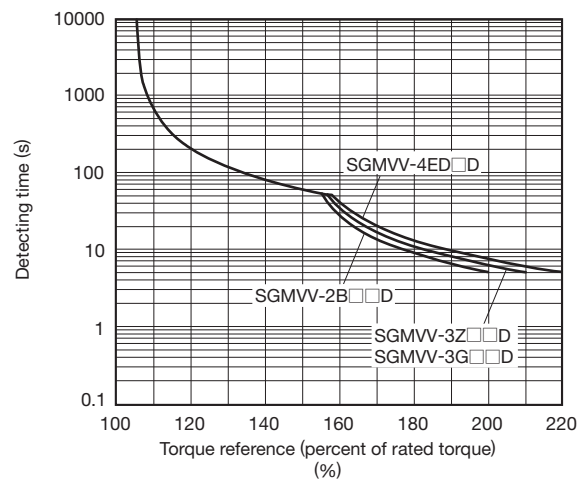

Note: Overload characteristics shown above do not guarantee continuous duty of 100% or more output.
Use a servomotor with effective torque within the continuous duty zone of *Torque-Motor Speed Characteristics*.

Specifications

● Basic Specifications

Items		Specifications		
Drive Method		Sine-wave current drive with PWM control of IGBT		
Feedback		Encoder: 20-bit (incremental, absolute)		
Operating Conditions	Surrounding Air Temperature	0°C to +55°C		
	Storage Temperature	-20°C to +85°C		
	Ambient Humidity	90% RH or less	With no freezing or condensation	
	Storage Humidity	90% RH or less		
	Vibration Resistance	4.9 m/s ²		
	Shock Resistance	19.6 m/s ²		
	Protection Class	IP10	An environment that satisfies the following conditions. · Free of corrosive or flammable gases · Free of exposure to water, oil, or chemicals · Free of dust, salts, or iron dust	
	Pollution Degree	2		
	Altitude	1000 m or less		
Others	Free of static electricity, strong electromagnetic fields, magnetic fields or exposure to radioactivity			
Overvoltage Category		III		
Harmonized Standards (Application pending)		UL508C EN 50178, EN 55011 group 1 class A, EN 61000-6-2, EN 1800-3, EN 61800-5-1, EN 954-1, IEC 61508-1 to 4		
Mounting		Standard: Base-mounted Optional: Duct-ventilated		
Performance	Speed Control Range	1:5000 (The lower limit of the speed control range must be lower than the point at which the rated torque does not cause the servomotor to stop.)		
	Speed Regulation*1	Load Regulation	0% to 100% load: ±0.01% max. (at rated speed)	
		Voltage Regulation	Rated voltage ±10%: 0% (at rated speed)	
		Temperature Regulation	25±25°C: ±0.1% max. (at rated speed)	
Torque Control Tolerance (Repeatability)		±1%		
I/O Signals	Encoder Output Pulse		Phase A, B, C: line driver Encoder output pulse: any setting ratio	
	Sequence Input	Input Signals which can be allocated	Number of Channels	7 ch
			Functions	· Forward run prohibited (P-OT), reverse run prohibited (N-OT) · General-purpose signals (/SI0 to /SI6) · Forward external torque limit (/P-CL), reverse external torque limit (/N-CL) · DB answer (/DBANS) Signal allocations can be performed, and positive and negative logic can be changed.
	Sequence Output	Output Signals which can be allocated	Fixed Output	Servo alarm (ALM) output
			Number of Channels	3 ch
	Functions	· Positioning completion (/COIN) · Speed coincidence detection (/V-CMP) · Rotation detection (/TGON) · Servo ready (/S-RDY) · Torque limit detection (/CLT) · Speed limit detection (/VLT) · Brake (/BK) · Warning (/WARN) · Near (/NEAR) Signal allocations can be performed, and positive and negative logic can be changed.		
Communications	RS-422A Communications (CN3)	Interface	Digital operator (Model: JUSP-OP05A-1-E), personal computer (can be connected with SigmaWin+)	
		1:N Communications	N = Up to 15 stations possible at RS-422A	
	Axis Address Setting	Set by parameter		
USB Communications (CN7)	Communications Standard	Interface	Personal computer (can be connected with SigmaWin+)	
		Complies with standard USB1.1. (12 Mbps)		
LED Display		CHARGE, and POWER indicators, one 7-segment LED		
Option Module Setting Switches		Rotary Switch (S2)	Position: 16 positions	
		DIP Switch (S3)	Number of pins: Four pins	

Specifications

● Basic Specifications (Cont'd)

Items		Specifications
Analog Monitor (CN5)		Number of points: 2 Output voltage: ±10VDC (linearity effective range ±8 V) Resolution: 16 bits Accuracy: ±20 mV (Typ) Max. output current: ±10 mA Settling time (±1%): 1.2 ms (Typ)
Dynamic Brake (DB)		Included An external dynamic brake unit is required. For information on the recommended Dynamic Brake Unit, refer to <i>Dynamic Brake Unit</i> on page 81.
Regenerative Processing		Included An external regenerative resistor unit is required. For information on the recommended regenerative resistor, refer to <i>Regenerative Resistor</i> on page 79.
Overtravel (OT) Prevention		Dynamic brake stop, deceleration to a stop, or free run to a stop at P-OT or N-OT
Protective Function		Overcurrent, overvoltage, insufficient voltage, overload, regeneration error, etc.
Utility Function		Gain adjustment, alarm history, JOG operation, origin search, etc.
Safety Function	Input	/HWBB1, /HWBB2: Baseblock signal for power module
	Output	EDM1: Monitoring status of internal safety circuit (fixed output)
	Standards* ² (Application pending)	EN 954 Category 3, IEC 61508 SIL2
Optional Module* ³		Fully-closed module, safety module, command option module

*1 : Speed regulation by load regulation is defined as follows:

$$\text{Speed regulation} = \frac{\text{No-load motor speed} - \text{Total load motor speed}}{\text{Rated motor speed}} \times 100\%$$

*2 : Implement risk assessment and confirm that the safety requirements of the machine have been met.

*3 : Refer to page 42 for combinations with modules.

Power Supply Capacities and Power Losses

The following table shows SERVOPACK's power supply capacities and power losses at the rated output.

Main Circuit Power Supply Voltage	Applicable Servomotor Max. Capacity kW	Combination of SERVOPACK and Converter		Power Supply Capacity for Each SERVOPACK-Converter Set kVA	Output Current Arms	Main Circuit Power Loss W	Regenerative Resistor Power Loss W	Control Circuit Power Loss W	Total Power Loss W
		SERVOPACK Model SGDV-	Converter Model SGDV-COA						
Three-phase 200 V	22	121H	2BAA	38	116	1200	(480) *1	120	1320
	30	161H	3GAA	52	160	1540	(960) *2	120	1660
	37	201H	3GAA	64	200	1540	(960) *3	120	1660
Three-phase 400 V	30	750J	3ZDA	52	76	1020	(720) *4	96	1116
	37	101J	5EDA	64	98	1240	(960) *5	96	1336
	55	131J	5EDA	95	130	1590	(1440) *6	96	1686

*1 : For the optional JUSP-RA08-E regenerative resistor.

*2 : For the optional JUSP-RA09-E regenerative resistor.

*3 : For the optional JUSP-RA11-E regenerative resistor.

*4 : For the optional JUSP-RA13-E regenerative resistor.

*5 : For the optional JUSP-RA14-E regenerative resistor.

*6 : For the optional JUSP-RA16-E regenerative resistor.

SERVOPACKs Same for All Models

External Dimensions Units: mm

All drawings on the following pages show the exterior of the analog voltage/pulse train reference SERVOPACK as examples. The external appearance and connectors depend on the SERVOPACK model.

See page 41 for combinations of SERVOPACKs and Converters.

Connector

Port	Model	Pin	Manufacturer
CN1	10250-52A2PL	50	3M Japan Ltd.
CN2	53984-0671	6	Molex Japan LLC
CN3	HDR-EC14LFDTN-SLE-PLUS	14	Honda Tsushin Kogyo Co., Ltd.
CN5*1	-	4	-
CN6A, CN6B*2	1903815-1	8	Tyco Electronics Japan G.K.
CN6A, CN6B*3	1981386-1	8	Tyco Electronics Japan G.K.
CN7	MNC23-5K5H00	5	ADVANCED-CONNECTEK INC.
CN8	1981080-1	8	Tyco Electronics Japan G.K.
CN103, CN104*1	-	3	-
CN115*1	-	3	-
CN901*1	-	9	-

*1 : Connect the special cables.

*2 : For MECHATROLINK-II Communications Reference SERVOPACKs

*3 : For MECHATROLINK-III Communications Reference SERVOPACKs

Note: The connectors above or their equivalents are used for SERVOPACKs.

● Base-Mounted Model

(1) Three-phase 200 VAC, 22 kW and 30 kW (Model: SGDV-121H, -161H)

Three-phase 400 VAC, 30 kW and 37 kW (Model: SGDV-750J, -101J)

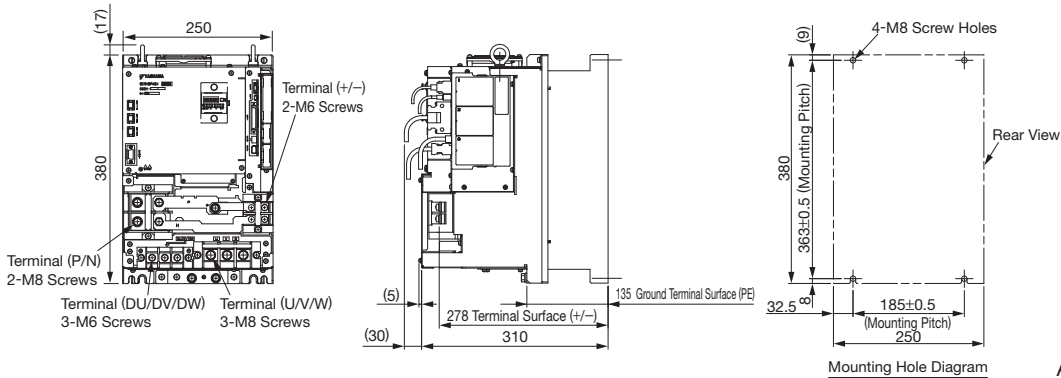

Approx. Mass: 22.5 kg

(2) Three-phase 200 VAC, 37 kW (Model: SGDV-201H)

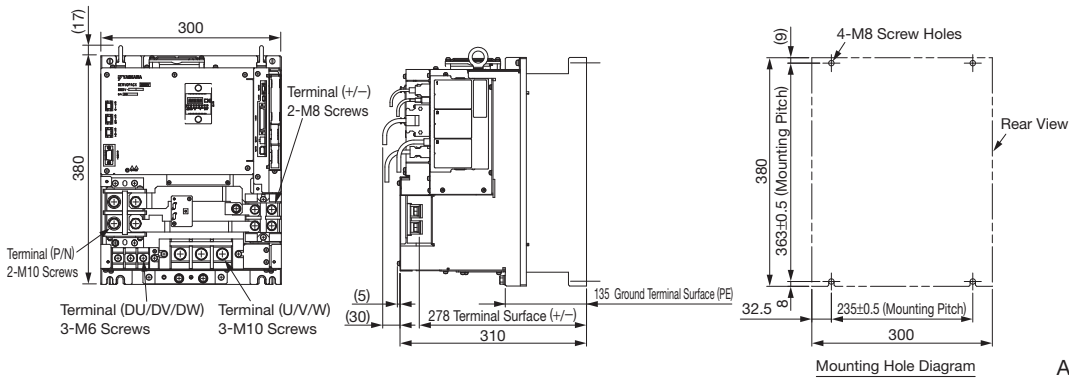

Approx. Mass: 29.3 kg

(3) Three-phase 400 VAC, 55 kW (Model: SGDV-131J)

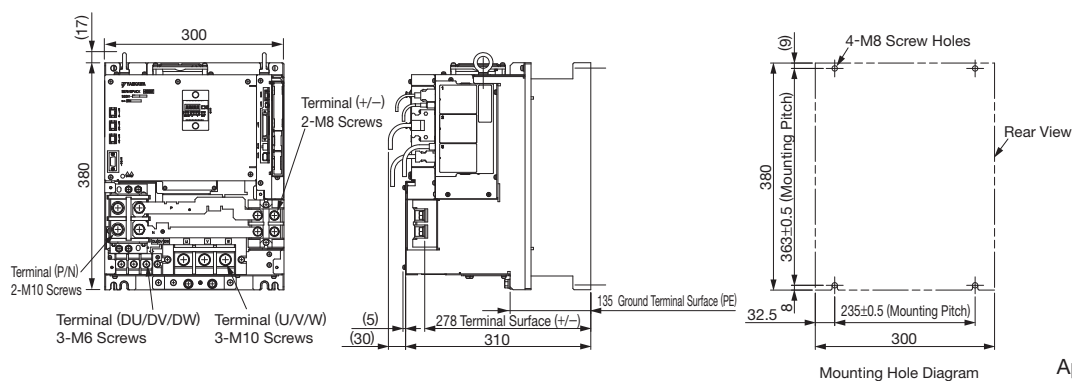

Approx. Mass: 25.7 kg

External Dimensions Units: mm

● Duct-ventilated Model

(1) Three-phase 200 VAC, 22 kW and 30 kW (Model: SGDV-121H, -161H)

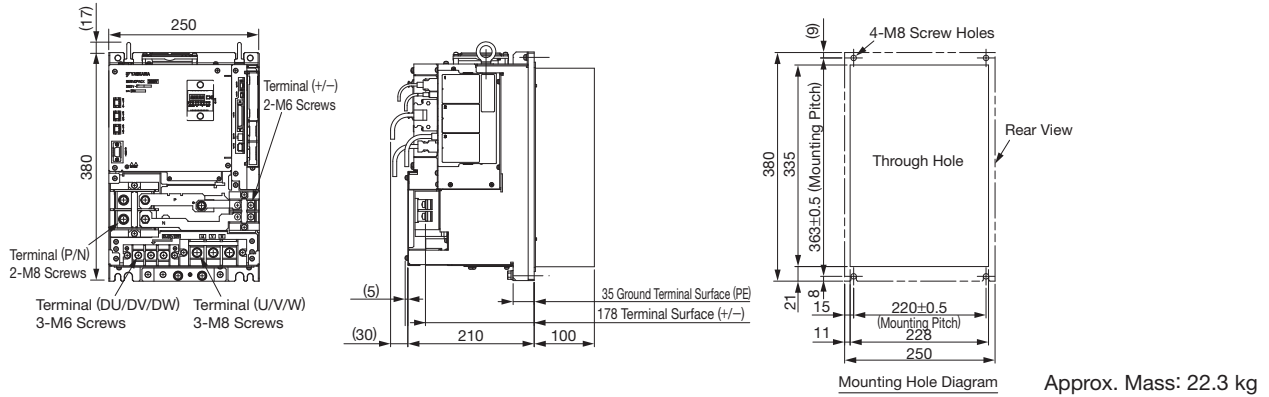

(2) Three-phase 200 VAC, 37 kW (Model: SGDV-201H)

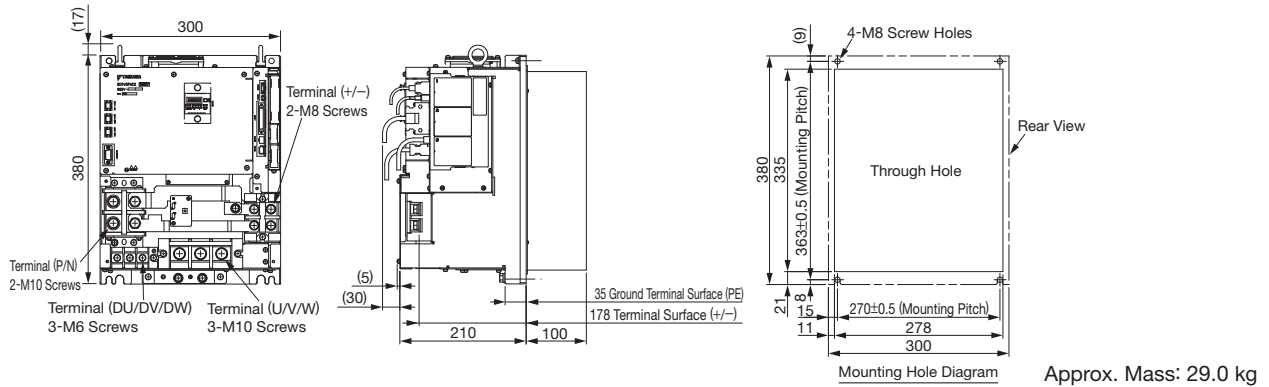

(3) Three-phase 400 VAC, 30 kW and 37 kW (Model: SGDV-750J, -101J)

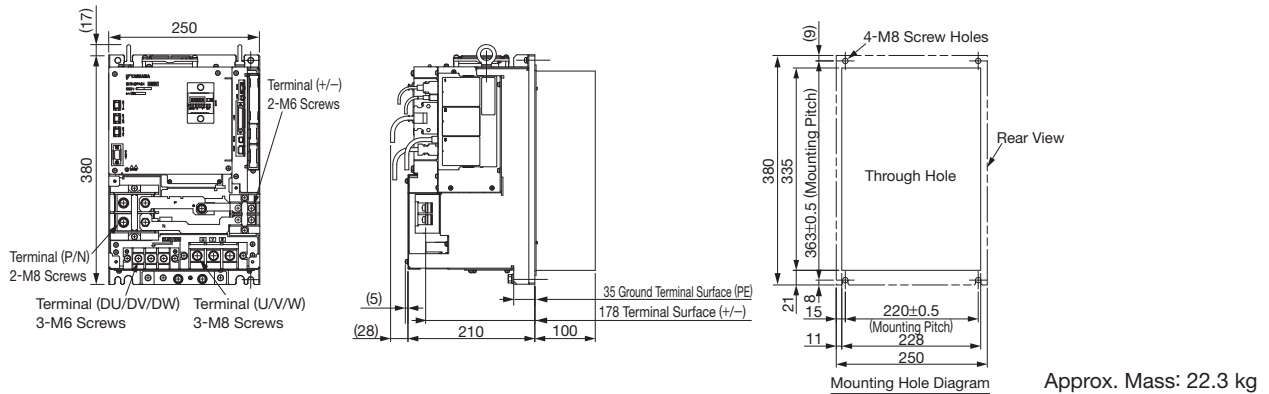

(4) Three-phase 400 VAC, 55 kW (Model: SGDV-131J)

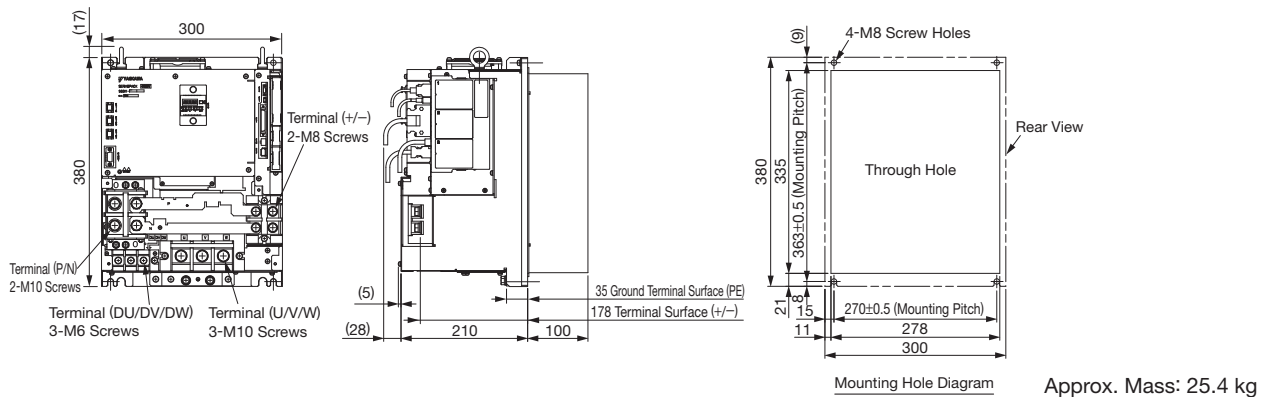

Converters

Ratings and Specifications

Main Circuit Power Supply Voltage		Three-phase 200 VAC		Three-phase 400 VAC	
Converter Model: SGD V-COA□□□□		2BAA	3GAA	3ZDA	5EDA
Input Power	Main Circuit	Three-phase 200 to 230 VAC +10% to -15% 50/60 Hz		Three-phase 380 to 480 VAC +10% to -15% 50/60 Hz	
	Control Circuit	Single-phase 200 to 230 VAC +10% to -15% 50/60 Hz		24 VDC ±15%	
Output Power	Main Circuit P/N	270 to 310 VDC		520 to 650 VDC	
	Control Circuit	24 VDC ±15%		24 VDC ±15%	
Regenerative Processing		An external regenerative resistor is required. For information on the recommended regenerative resistor, refer to <i>Regenerative Resistor</i> on page 79.			
Rectification Method		Three-phase full-wave rectification			
Operating Conditions	Surrounding Air Temperature	0°C to +55°C			
	Storage Temperature	-20°C to +85°C			
	Operating/Storage Humidity	90%RH or less (no condensation)			
	Vibration/Shock Resistance	4.9 m/s ² / 19.6 m/s ²			
Altitude		1000 m or less			
Mounting		Standard: Base-mounted Optional: Duct-ventilated			
I/O Signals (SERVOPACK Interface)		SERVOPACK control I/O signals			
Display		CHARGE indicator			
Protective Functions		Protection for lost power phase, main circuit voltage error, overvoltage, insufficient voltage, blown fuse, heat sink overheat, stopped fan, etc.			
Utility Functions		Rapid discharge function			

Note: Refer to page 5 for combinations with SERVOPACKs.

External Dimensions Units: mm

Connector

Port	Model	Pin	Manufacturer
CN101	231-202/026-000	2	WAGO Company of Japan, Ltd
CN103, CN104*	-	3	-
CN901*	-	20	-

* : Connect the special cables.

● Base-Mounted Model

(1) Three-phase 200 VAC (Model: SGDV-COA2BAA)

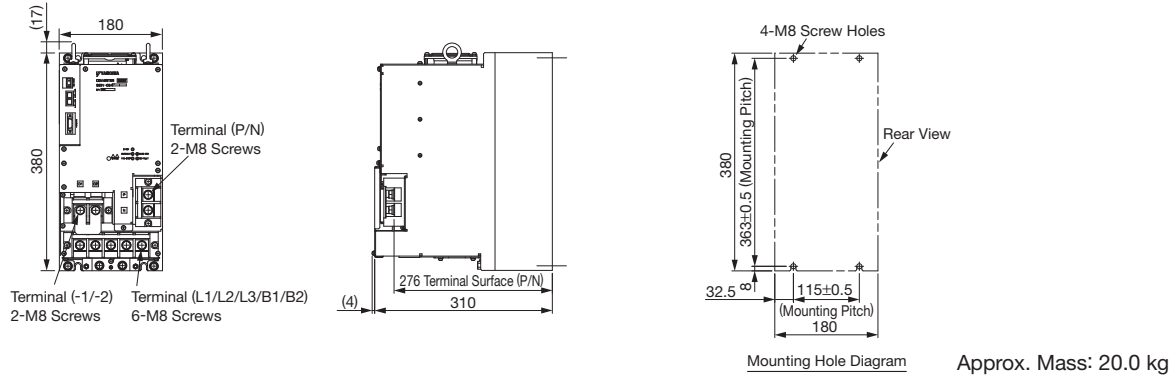

(2) Three-phase 200 VAC (Model: SGDV-COA3GAA)

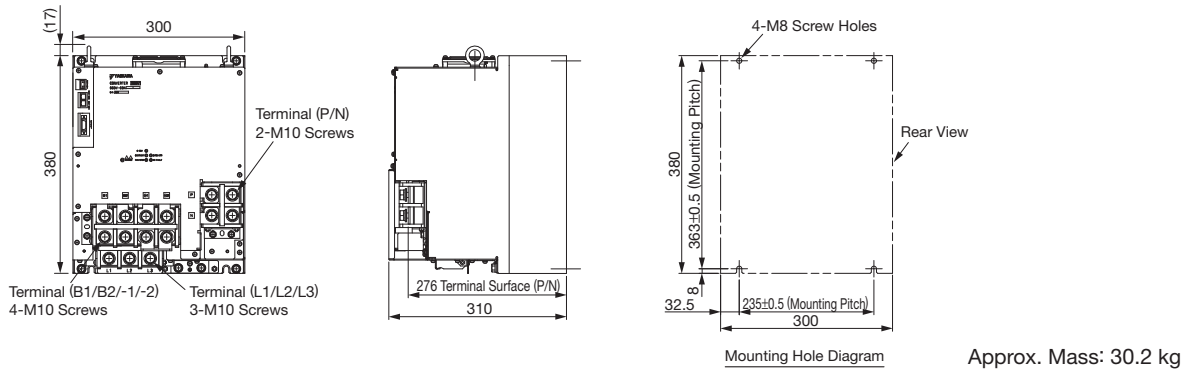

(3) Three-phase 400 VAC (Model: SGDV-COA3ZDA)

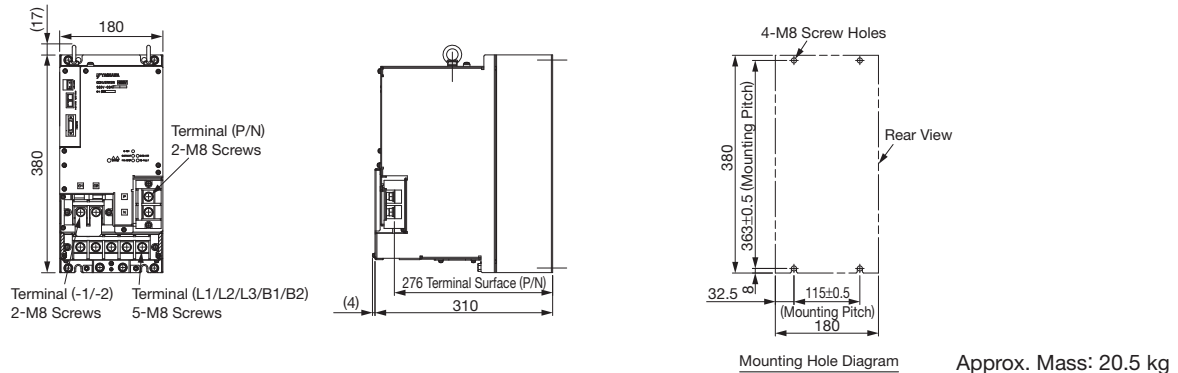

(4) Three-phase 400 VAC (Model: SGDV-COA5EDA)

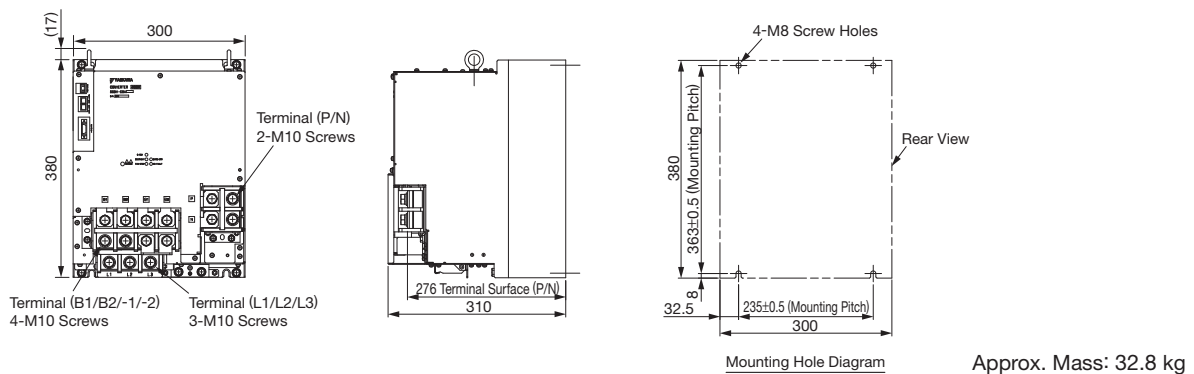

External Dimensions Units: mm

● Duct-ventilated Model

(1) Three-phase 200 VAC (Model: SGDV-COA2BAA)

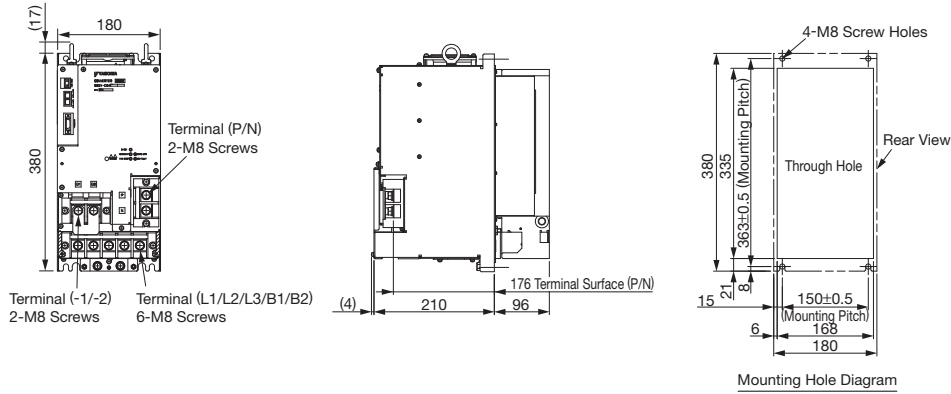

Approx. Mass: 17.2 kg

(2) Three-phase 200 VAC (Model: SGDV-COA3GAA)

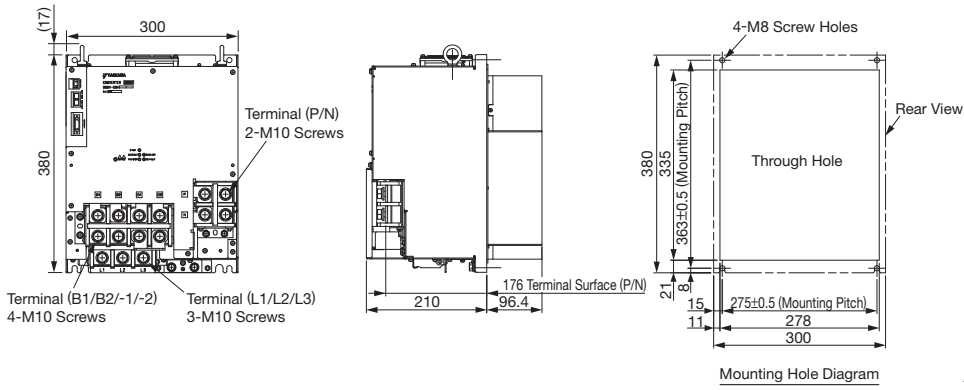

Approx. Mass: 26.4 kg

(3) Three-phase 400 VAC (Model: SGDV-COA3ZDA)

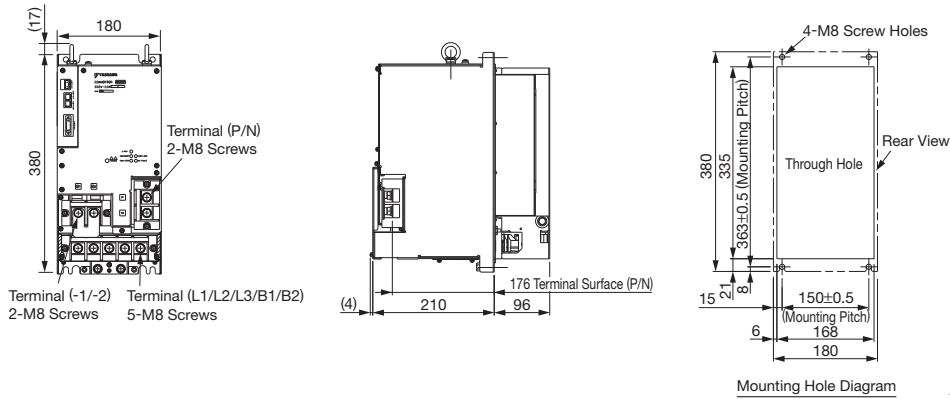

Approx. Mass: 17.7 kg

(4) Three-phase 400 VAC (Model: SGDV-COA5EDA)

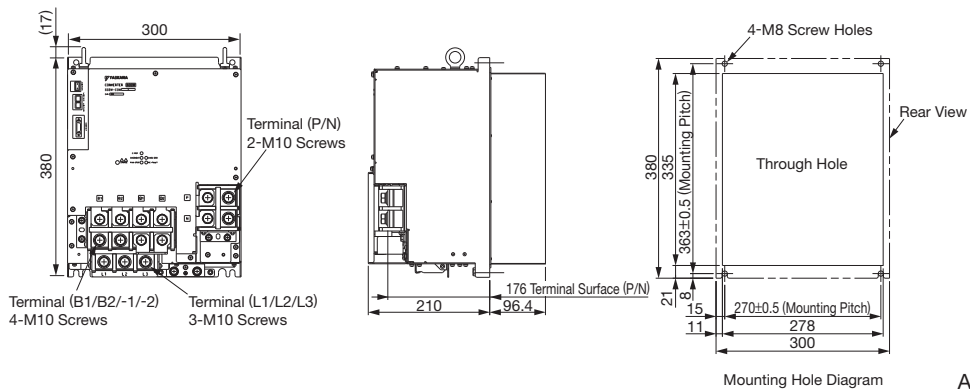

Approx. Mass: 29.0 kg

External Dimensions **Combinations of SERVOPACKs and Converters** Units: mm

Note: The following figures show the SERVOPACKs and converters for 200-VAC models. The dimensions of the 400-VAC models are the same.

(1) Three-phase 200 VAC, 22 kW (22-kW converter and SERVOPACK)
Three-phase 400 VAC, 30 kW (30-kW converter and SERVOPACK)

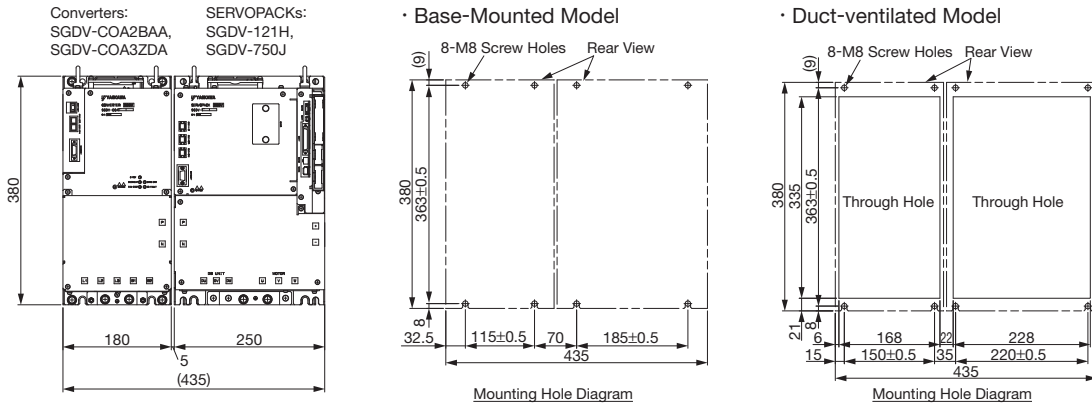

(2) Three-phase 200 VAC, 30 kW (37-kW converter and 30-kW SERVOPACK)
Three-phase 400 VAC, 37 kW (55-kW converter and 37-kW SERVOPACK)

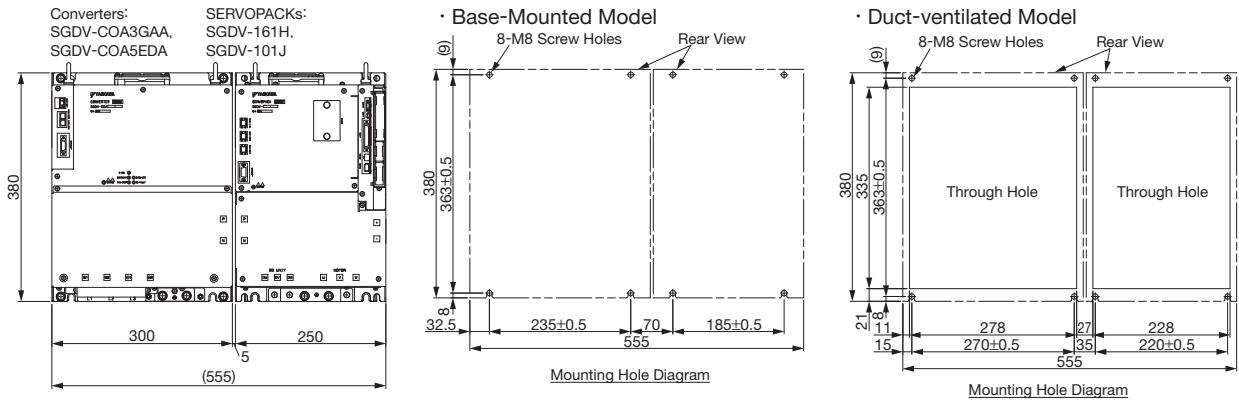

(3) Three-phase 200 VAC, 37 kW (37-kW converter and SERVOPACK)
Three-phase 400 VAC, 55 kW (55-kW converter and SERVOPACK)

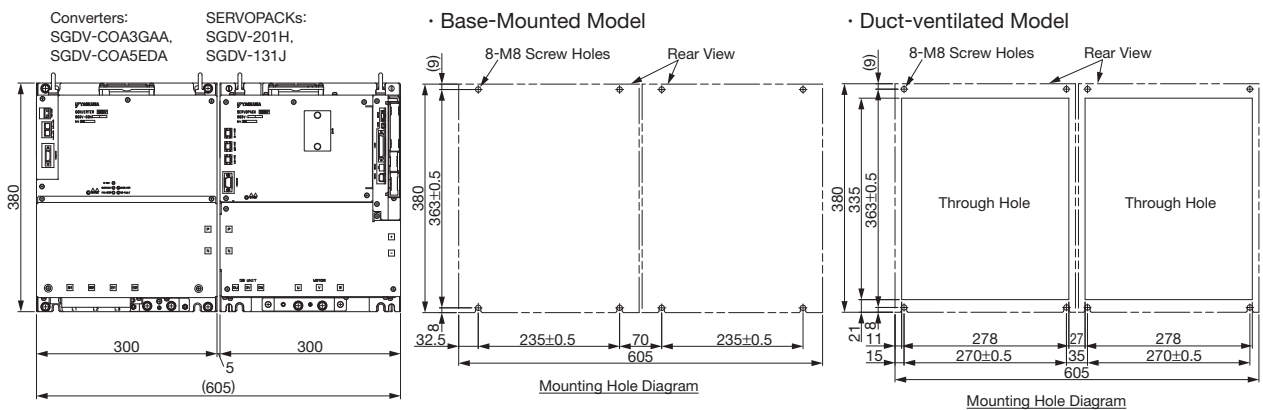

Option Modules

Combination of SERVOPACKs and Option Modules

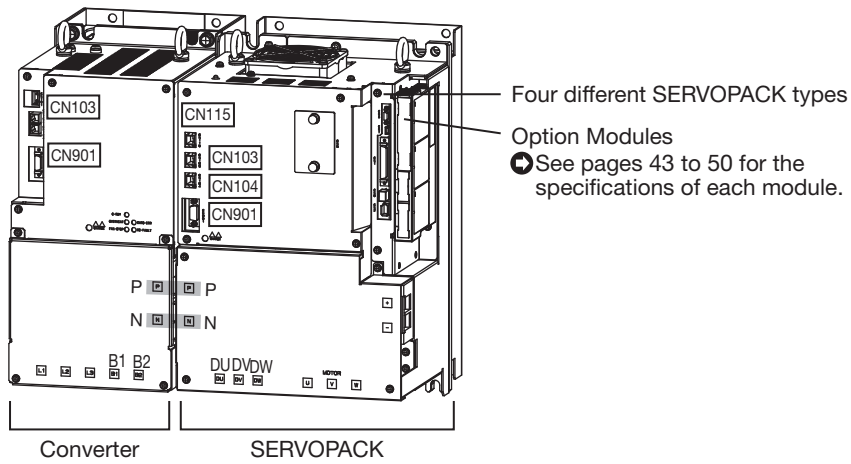

✓ : Possible – : Not Possible

SERVOPACK (Model)	Option Module		
	Safety Module (SGDV-OSA01A)	Fully-closed Module (SGDV-OFA01A)	
Analog Voltage/Pulse Train Reference (SGDV-□□□□01A)	✓	✓	
MECHATROLINK-II Communications Reference (SGDV-□□□□11A)	✓	✓	
MECHATROLINK-III Communications Reference (SGDV-□□□□21A)	✓	✓	
Command Option Attachable Type (SGDV-□□□□E1A)	Command Option Modules		
	INDEXER (SGDV-OCA03A)	–	✓
	DeviceNet*1 (SGDV-OCA04A)	✓	✓
	DeviceNet*2 (SGDV-OCA05A)	✓	✓

*1 : Driven by SERVOPACK control power supply

*2 : Driven by external power supply

- For SERVOPACKs in the large-capacity Σ -V series, an option module case kit is not required.
- Dimensions of the SERVOPACK are the same for SERVOPACKs with and without option modules.

Safety Module : Model SGDV-OSA01A

Specifications

Items		Specifications
Placement		Attached to the SERVOPACK
Power Specification	Power Supply Method	Supplied from the control power supply of the SGDV SERVOPACK.
Operating Conditions	Surrounding Air/Storage Temperature	0°C to +55°C/ -20°C to +85°C
	Ambient/Storage Humidity	90% RH or less (with no condensation)
	Vibration/Shock Resistance	4.9 m/s ² / 19.6 m/s ²
	Protection Class/ Pollution Degree	Protection class: IP10, Pollution degree: 2 An environment that satisfies the following conditions. <ul style="list-style-type: none"> • Free of corrosive or explosive gases • Free of exposure to water, oil or chemicals • Free of dust, salts or iron dust
	Altitude	1000 m or less
Others		Free of static electricity, strong electromagnetic fields, magnetic fields or exposure to radioactivity
Others		Active Mode Function
Response Time		Max. 200 ms

● Compliance with North American Safety Standards, European Directives, and Safety Standards (SERVOPACK + Safety Module)

Items		Specifications
North American Safety Standards		UL508C (E147823)
European Directives	Machinery Directive (2006/42/EC)	EN ISO 13849-1: 2008
	EMC Directive (2004/108/EC)	EN 55011 group 1, class A EN 61000-6-2 EN 61800-3
	Low Voltage Directive (2006/95/EC)	EN 50178 EN 61800-5-1
Safety Standards	Safety of Machinery	EN ISO 13849-1, IEC 60204-1
	Functional Safety	IEC 61508-1 to -4, IEC 62061, IEC 61800-5-2
	EMC Directive	IEC 61326-3-1
Safety Functions	Number of Functions: 2	
	Safety Function A	Inputs: 2 Channels, Function: Safety Request Input Signal (SRI-A1, SRI-A2) Output: 1 Channel, Function: External Device Monitor Output Signal (EDM-A)
	Safety Function B	Inputs: 2 Channels, Function: Safety Request Input Signal (SRI-B1, SRI-B2) Output: 1 Channel, Function: External Device Monitor Output Signal (EDM-B)
	Safety Functions (IEC61800-5-2) Function names of Safety Module	
Stopping Methods	Safe Torque Off (STO)	Safe BaseBlock Function (SBB function)
	Safe Stop 1 (SS1)	Safe BaseBlock with Delay Function (SBB-D function)
	Safe Stop 2 (SS2)	Safe Position Monitor with Delay Function (SPM-D function)
	Safety-Limited Speed (SLS)	Safely Limited Speed with Delay Function (SLS-D function)
Safe Performance		
Safety Integrity Level		SIL2, SILCL2
Probability of Dangerous Failure per Hour		PFH = 7.0×10 ⁻⁹ [1/h] (SSB)
Performance Level		PLd (Category 2)
Mean Time to Dangerous Failure of Each Channel		MTTFd: High
Average Diagnostic Coverage		DCave: Medium
Proof Test Interval		10 years

➡ See the *Selecting Cables* for cables.

Fully-closed Module : Model SGDV-OFA01A

System Configuration of Fully-closed Module

● System Configuration

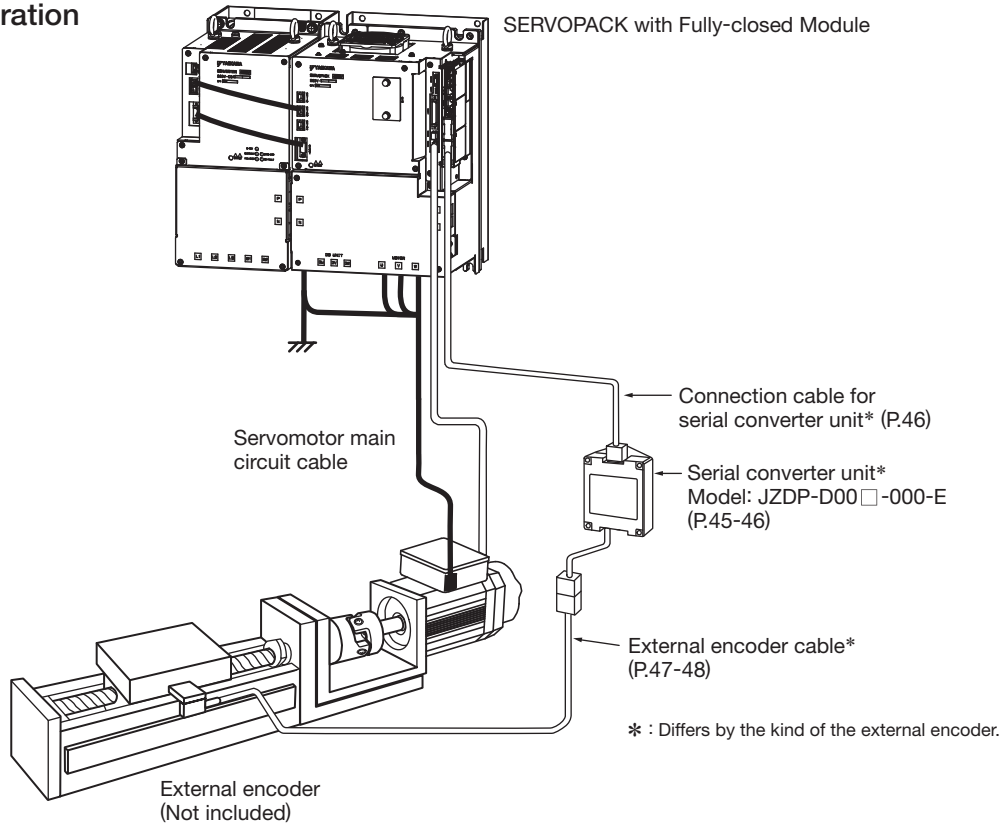

● External Encoder Sine Wave Pitch and Number of Divisions

Type of External Encoder	Manufacturer	External Encoder Model	Sine Wave Pitch [μm]	Models for Serial Converter Unit or Models for Head with Interpolator	Number of Divisions	Resolution
Incremental	HEIDENHAIN	LIDA48□	20	JZDP-D003-□□□-E*1	256	0.078 μm
		LIF48□	4	JZDP-D003-□□□-E*1	256	0.016 μm
	Renishaw plc	RGH22B	20	JZDP-D005-□□□-E*1	256	0.078 μm
	Magnescale Co., Ltd.	SR75-□□□□LF*4	80	-	8192	0.0098 μm
		SR75-□□□□MF	80	-	1024	0.078 μm
		SR85-□□□□LF*4	80	-	8192	0.0098 μm
		SR85-□□□□MF	80	-	1024	0.078 μm
	SL700*4, SL710*4, SL720*4, SL730*4	800	PL101-RY*2	8192	0.0977 μm	
Absolute	Mitutoyo Corporation	ST781A/ST781AL	256	-	512	0.5 μm
		ST782A/ST782AL	256	-	512	0.5 μm
		ST783/ST783AL	51.2	-	512	0.1 μm
		ST784/ST784AL	51.2	-	512	0.1 μm
		ST788A/ST788AL	51.2	-	512	0.1 μm
		ST789A/ST789AL*5	25.6	-	512	0.05 μm
	Magnescale Co., Ltd.	SR77-□□□□LF*4	80	-	8192	0.0098 μm
		SR77-□□□□MF	80	-	1024	0.078 μm
		SR87-□□□□LF*4	80	-	8192	0.0098 μm
		SR87-□□□□MF	80	-	1024	0.078 μm
		RU77-4096ADF*3	-	-	256	20 bits
	RU77-4096AFFT01*3	-	-	1024	22 bits	
	HEIDENHAIN	LIC4100 Series+EIB3391Y	-	-	4096	0.005 μm

*1 : Models for serial converter units.

*2 : Models for heads with interpolators.

*3 : Models for rotational external encoders.

*4 : When using the encoder pulse output with these external encoders, the setting range of Pn281 is restricted.

*5 : For details on this external encoder, contact Mitutoyo.

Note: Refer to the manuals for the external encoder and serial converter unit for details on the sine wave pitch and the number of divisions of the external encoder.

Serial Converter Units

● Model Designations

JZDP - D00□ - 000 - E

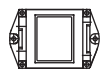
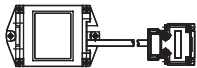
Serial Converter Unit Model			
Code	Appearance	Applicable External Encoder	Hall Sensor
D003		Manufactured by HEIDENHAIN Corporation	None
D005		Manufactured by Renishaw plc.	None

Note: Using the serial converter unit JZDP-A□□□ with SGDV SERVOPACK will void our guarantee.

● Characteristics and Specifications

Items	JZDP-D00□-000-E	
Electrical Characteristics	Power Supply Voltage	+5.0 V±5%, ripple content 5% max.
	Current Consumption*1	120 mA typ. 350 mA max.
	Signal Resolution	Input two-phase sine wave: 1/256 pitch
	Max. Response Frequency	250 kHz
	Analog Input Signals*2 (cos, sin, Ref)	Differential input amplitude: 0.4 to 1.2 V Input signal level: 1.5 to 3.5 V
	Output Signal*3	Position data, alarms
	Output Method	Serial data communications
Mechanical Characteristics	Output Circuit	Balanced type transceiver (SN75LBC176 or the equivalent), internal terminating resistor: 120 Ω
	Approx. Mass	150 g
	Vibration Resistance	98 m/s ² max. (10 to 2500 Hz) in three directions
Environmental Conditions	Impact Resistance	980 m/s ² , (11 ms) two times in three directions
	Surrounding Air Temperature	0°C to +55°C
	Storage Temperature	-20°C to +80°C
	Humidity	20% to 90%RH (no condensation)

- *1 : The current consumption of the linear scale and hall sensor is not included in this value. The current consumption of linear scale and hall sensor must be taken into consideration for the current capacity of host controller that supplies the power. The current consumption of hall sensor: Approx. 40 mA.
- *2 : Input a value within the specified range. Otherwise, incorrect position information is output, and the device may be damaged.
- *3 : The transmission is enabled 100 to 300 ms after the power turns on.

● Analog Signal Input Timing

The following figure shows the input timing of the analog signals. When the cos and sin signals are shifted 180 degrees, the differential signals are the /cos and /sin signals.

The specifications of the cos, /cos, sin, and /sin signals are identical except for the phase.

Ref and /Ref signals are input to the converter. Input the signals by taking into account hysteresis of the receiving circuit so that the signals will satisfy the specifications shown in the figure on the right. When they are crossed, the output data will be counted up.

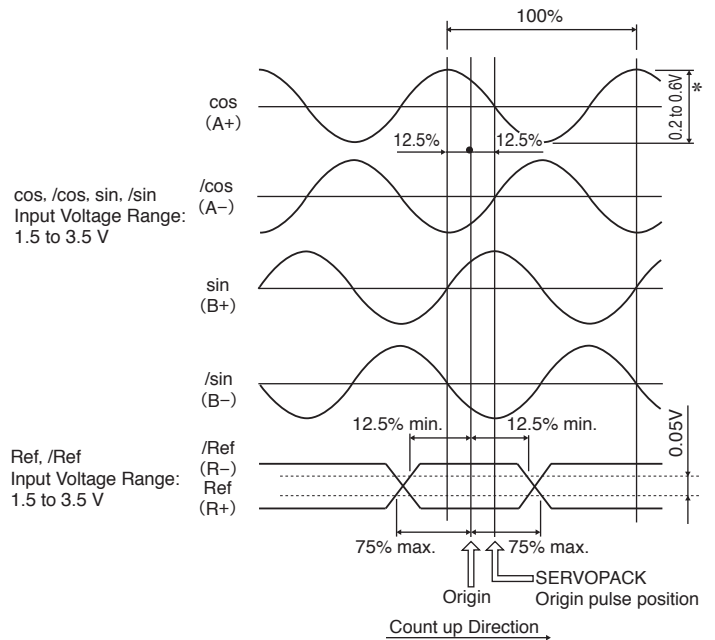

*: If the analog signal amplitude declines to about 0.35 V because of differential amplitude, the serial converter outputs an alarm.

IMPORTANT

■ Precautions

- 1 Never perform insulation resistance and withstand voltage tests.
- 2 When analog signals are input to the serial converter unit, noise influence on the analog signals affects the unit's ability to output correct position information. The analog cable must be as short as possible and shielded.
- 3 Do not connect or disconnect the unit while power is being supplied, or the unit may be damaged.
- 4 When using multiple axes, use a shield cable for each axis. Do not use a shield cable for multiple axes.
- 5 When using the serial converter unit with linear encoders other than recommended encoders, be sure to thoroughly evaluate them before use.

Fully-closed Module : Model SGDV-OFA01A

Serial Converter Units

External Dimensions (Units: mm)

(1) Model: JZDP-D003-000-E

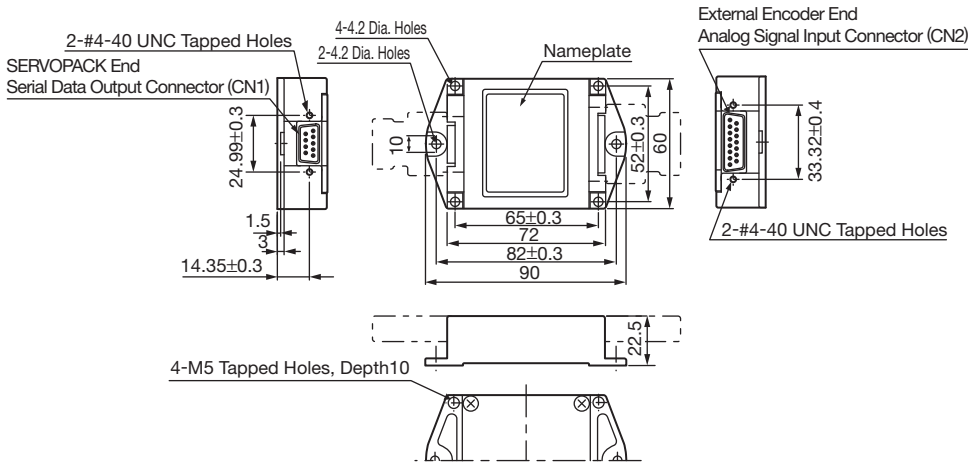

(2) Model: JZDP-D005-000-E

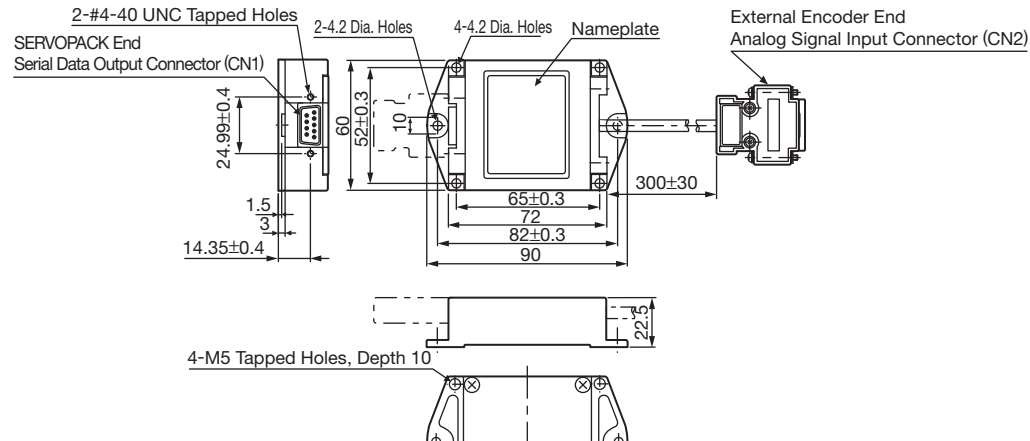

Connection Cables

Recommended Cables

Name	Application	Model	Length
Cable for Connecting Serial Converter Unit	Between the CN31 connector for SERVOPACK with the Fully-closed Module and the serial converter unit.	JZSP-CLP70-03-E	3 m
		JZSP-CLP70-05-E	5 m
		JZSP-CLP70-10-E	10 m
		JZSP-CLP70-15-E	15 m
		JZSP-CLP70-20-E	20 m

External Dimensions (Units: mm)

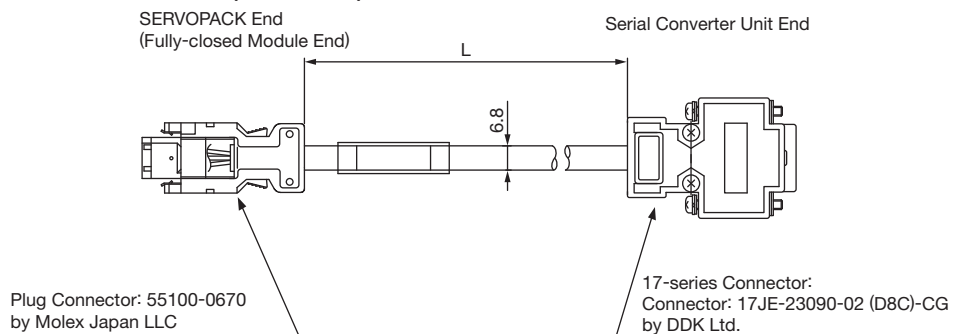

Serial Converter Units

● Connection Examples

(1) Connection Example with External Encoder by HEIDENHAIN Corporation

· Model: JZDP-D003-000-E

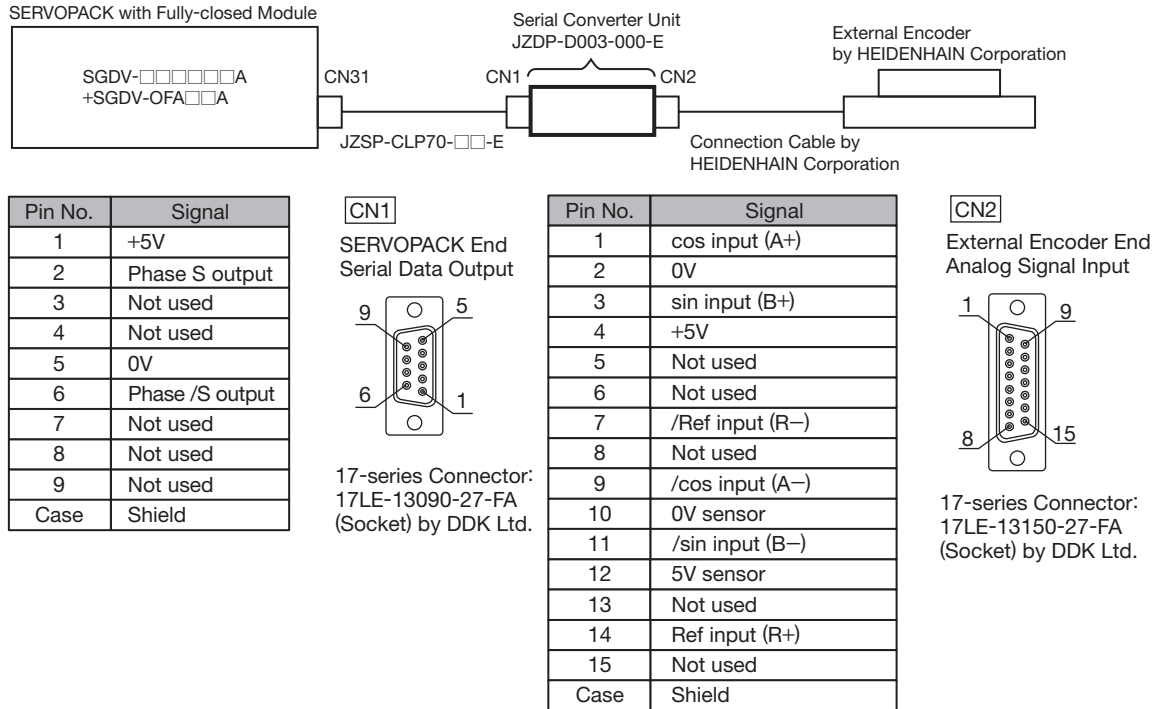

Notes: 1 Do not use the unused pins.

2 The external encoder (analog 1 Vp-p output, D-sub 15-pin) by HEIDENHAIN Corporation can be directly connected.

(2) Connection Example with External Encoder by Renishaw plc.

· Model: JZDP-D005-000-E

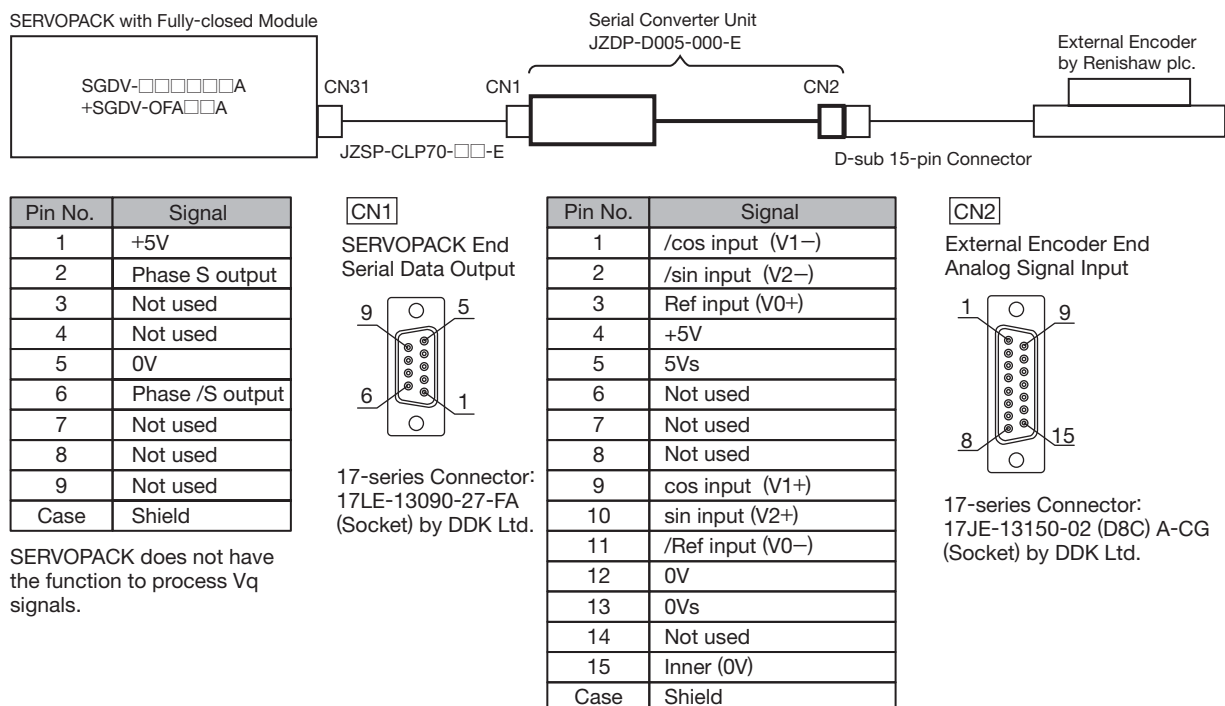

Notes: 1 Do not use the unused pins.

2 The external encoder (analog 1 Vp-p output, D-sub 15-pin) by Renishaw plc. can be directly connected. However, the BID and DIR signals are not connected.

3 Use the external encoder-end connector to change the home position specifications of the external encoder.

Fully-closed Module : Model SGDV-OFA01A

External Encoder Applicable for Yaskawa's Serial Interface

● Connection Examples

(1) Connection Example with External Encoder by Mitutoyo Corporation (Model: ABS ST78□A□)

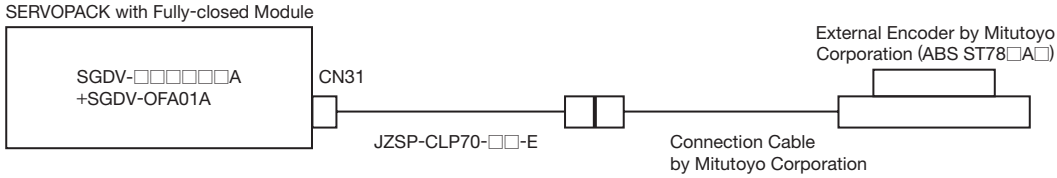

(2) Connection Example with External Encoders by Magnescale Co., Ltd. (Model: SR□5, SR□7*1, RU77*2)

- *1 : External absolute encoder
- *2 : External single-turn absolute encoder

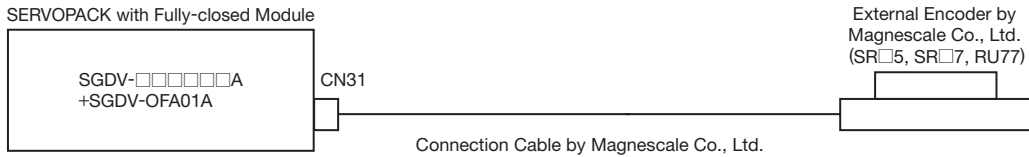

• Cables

To connect a SERVOPACK and a linear scale, use a cable (Model no.: CH33-xx□□G) for SR□5 or SR□7 linear scales by Magnescale Co., Ltd. This cable has connectors designed for use with Yaskawa products.
 To connect a SERVOPACK and a rotary scale, use an extension cable for RU77 linear scales in the CE28 series by Magnescale Co., Ltd.

(3) Connection Example with External Encoders by Magnescale Co., Ltd. (Model: SL7□0)

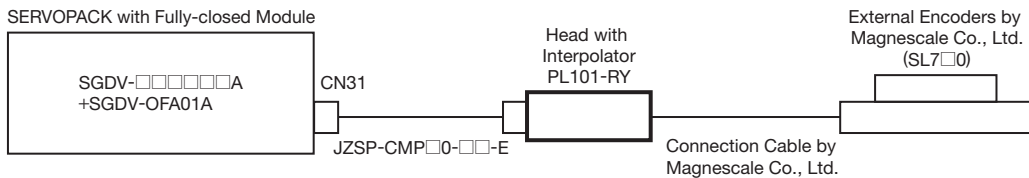

• Cables

Name	Length (L)	Order No.		Specifications
		Standard Type	Flexible Type	
Cable with Connectors (For Incremental and Absolute Encoder)	3 m	JZSP-CMP00-03-E	JZSP-CMP10-03-E	
	5 m	JZSP-CMP00-05-E	JZSP-CMP10-05-E	
	10 m	JZSP-CMP00-10-E	JZSP-CMP10-10-E	
	15 m	JZSP-CMP00-15-E	JZSP-CMP10-15-E	
	20 m	JZSP-CMP00-20-E	JZSP-CMP10-20-E	

(4) Connection Example with External Encoders by HEIDENHAIN Corporation (LIC4100 Series+EIB3391)

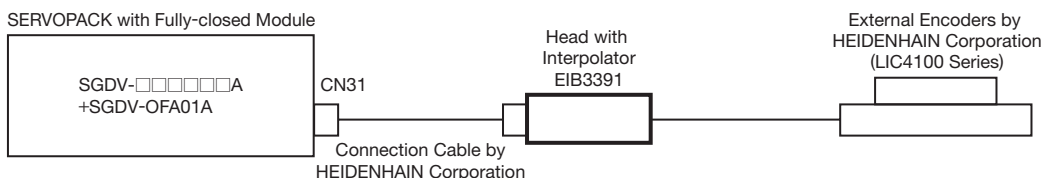

Command Option Modules INDEXER : Model SGDV-OCA03A

Specifications

Items		Specifications			
Placement		Attached to the SERVOPACK			
Power Specifications	Power Supply Method	Supplied from the control power supply of the SGDV SERVOPACK.			
Operating Conditions	Surrounding Air/Storage Temperature	0°C to +55°C/ -20°C to +85°C			
	Ambient/Storage Humidity	90% RH or less (with no condensation)			
	Vibration/Shock Resistance	4.9 m/s ² / 19.6 m/s ²			
	Protection Class/Pollution Degree	Protection class: IP10, Pollution degree: 2 An environment that satisfies the following conditions. <ul style="list-style-type: none"> • Free of corrosive or explosive gases • Free of exposure to water, oil or chemicals • Free of dust, salts or iron dust 			
	Altitude	1000 m or less			
Others		Free of static electricity, strong electromagnetic fields, magnetic fields or exposure to radioactivity			
Control Method	Program Table Method	Program table positioning in which steps are executed sequentially by commands given through contact input or serial communications Positioning in which station numbers are specified by commands given through contact input or serial communications			
		Max. Number of Steps	256		
		Max. Number of Tables	256		
	Max. Number of Stations	256			
Serial Communications Method		Serial command by 1-channel ASCII code Communications specifications: RS-422/485 (50 m max.) Connection topology: Multi-drop connection (16 axes max.) Baud rate: 9600, 19200, 38400 bps			
Other Functions		Registration (positioning by external signal), homing			
Display	LED	Red, Green (Status display)			
I/O Signal	Sequence Input Signals	Mode selection (/MODE0/1)			
		<table border="1"> <thead> <tr> <th>Mode 0</th> <th>Mode 1</th> </tr> </thead> <tbody> <tr> <td> <ul style="list-style-type: none"> • Starts or interrupts program table operation (/START-STOP) • Resets program table operation (/PGMRES) • Program table selection 0 (/SEL0) to to • Program table selection 7 (/SEL7) </td> <td> <ul style="list-style-type: none"> • Starts homing (/HOME) • Starts forward JOG operation (/JOGP) • Starts reverse JOG operation (/JOGN) • JOG speed table selection 0 (/JOG0) to to • JOG speed table selection 3 (/JOG3) </td> </tr> </tbody> </table>	Mode 0	Mode 1	<ul style="list-style-type: none"> • Starts or interrupts program table operation (/START-STOP) • Resets program table operation (/PGMRES) • Program table selection 0 (/SEL0) to to • Program table selection 7 (/SEL7)
	Mode 0	Mode 1			
<ul style="list-style-type: none"> • Starts or interrupts program table operation (/START-STOP) • Resets program table operation (/PGMRES) • Program table selection 0 (/SEL0) to to • Program table selection 7 (/SEL7) 	<ul style="list-style-type: none"> • Starts homing (/HOME) • Starts forward JOG operation (/JOGP) • Starts reverse JOG operation (/JOGN) • JOG speed table selection 0 (/JOG0) to to • JOG speed table selection 3 (/JOG3) 				
Sequence Output Signals	<ul style="list-style-type: none"> • Positioning completed (/INPOSITION) • Programmable output 0 to 7 (/POUT0 to /POUT7) 				

● Program Table Functions

	Function	Setting Range	Setting Unit	Description
PGMSTEP	Program step	—	—	Program step number (0 to 255)
POS	Target position	-99,999,999 to +99,999,99	Reference unit	Specifies the target position. Absolute position (A), relative distance (I), infinite length (INFINITE), Stop (STOP), no motion command (-)
SPD	Positioning speed	1 to 99,999,999	×1000 reference units/min	Specifies the positioning speed.
RDST	External positioning distance	0 to 99,999,999	Reference unit	Specifies registration distance. For no registration, set "-".
RSPD	External positioning speed	1 to 99,999,999	×1000 reference units/min	Specifies registration speed.
ACC	Acceleration	1 to 99,999,999	×1000 reference units/min/ms	Specifies acceleration for positioning or registration. To continue with the acceleration specified in the previously executed program step, set ":".
DEC	Deceleration	1 to 99,999,999	×1000 reference units/min/ms	Specifies deceleration for positioning or registration. To continue with the deceleration specified in the previously executed program step, set ":".
POUT	Programmable output signals	—	—	Specifies the operation of programmable output signals /POUT0 to /POUT7. Active (A), inactive (N), ZONE signal (Z), maintain previous condition (:)
EVENT	Pass condition	0 to 99,999 (Waiting time settings)	ms	Sets waiting time (Tn) and any one of the following in tandem: Positioning completion signal (I), position reference distribution completed signal (D), positioning near signal (N), or selection signal (SELn)
LOOP	Number of executions	1 to 99,999	—	Specifies the number of executions from positioning start to pass condition (EVENT).
NEXT	Program step to be executed next	0 to 255	—	Specifies the program step (PGMSTEP) to be executed next. To end program table operation, set "END".

➤ See the *Selecting Cables* for cables.

Command Option Modules DeviceNet : Model SGDV-OCA04A, OCA05A

Specifications

Items		Specifications	
		SGDV-OCA04A DeviceNet Module (Driven by SERVOPACK control power supply)	SGDV-OCA05A DeviceNet Module (Driven by external power supply)
Power Supply Method	Control Section	Supplied from the control power supply of a command option-attachable SERVOPACK.	Supplied from the DeviceNet cable.
	DeviceNet Communications Section	Supplied from the DeviceNet cable.	
Current Consumption	Control Section	Included in the current consumption of the command option-attachable SERVOPACK.	100 mA max for 24-VDC power supply 200 mA max for 11-VDC power supply
	DeviceNet Communications Section	25 mA max.	
Operating Conditions	Surrounding Air/Storage Temperature	0°C to +55°C/ -20°C to +85°C	
	Ambient Operating and Storage Humidity	90% RH max. (with no condensation)	
	Vibration and Shock Resistance	Vibration: 4.9 m/s ² , Shock: 19.6 m/s ²	
	Protection Class and Pollution Degree	Protection class: IP10, Pollution degree: 2 However, the following conditions must be met. <ul style="list-style-type: none"> • There must be no corrosive or explosive gases. • There must be no exposure to water, oil or chemicals. • There must be no excessive dust, salts or iron dust in the environment. 	
	Altitude	1,000 m max.	
	Others	Free of static electricity, strong electromagnetic fields, magnetic fields, or exposure to radioactivity.	
Command Method	Operation Specifications	Positioning via DeviceNet communications	
	Reference input	DeviceNet communications Commands: Movement references (positioning or speed) and homing	
Position Control Functions	Acceleration/Deceleration Method	Linear, asymmetrical, exponential, and S-curve acceleration/deceleration	
	Operating Methods	Simple positioning, homing, continuous speed operation, and switching to positioning	
	Fully-closed Control	Supported.	
Input Signals	Always Assigned to CN1	Counterclockwise overtravel prohibition (CCW-OT), clockwise overtravel prohibition (CW-OT), home signal input (/HOME), and external stop input (EXSTOP)	
Output Signals	Always Assigned to CN1	Brake (/BK), servo alarm (ALM), warning (/WARN), and servo ready (/S-RDY)	
Built-in Functions	Position data latching	Position data can be latched on phase C, the home signal, or the external signal.	
	LED Indicators	<ul style="list-style-type: none"> · MS: Module status · NS: Network status 	
DeviceNet Communications	Communications Method	DeviceNet I/O communications and explicit messages	
	Topology	Multidrop or T-branching*	
	Baud Rate	125 kbps, 250 kbps, or 500 kbps	
	Cables	Special cables (OMRON DCA1-5CN02F1 cable with connectors or the equivalent.)	
	Max. Number of Nodes	64 nodes (including the master, maximum number of slaves: 63)	
	Node Address Settings	0 to 63 (Set on NA x10 and x1 rotary switches.)	
	Connectors for Communications	Micro-style connector (shielded)	
Max. Network Length	125 kbps: 500 m; 250 kbps: 250 m; 500 kbps: 100 m		

* : Externally connected terminating resistance is required.

Selecting Cables

System Configuration

A system configuration for a three-phase main circuit power supply voltage of 400 VAC is shown in the following figure.

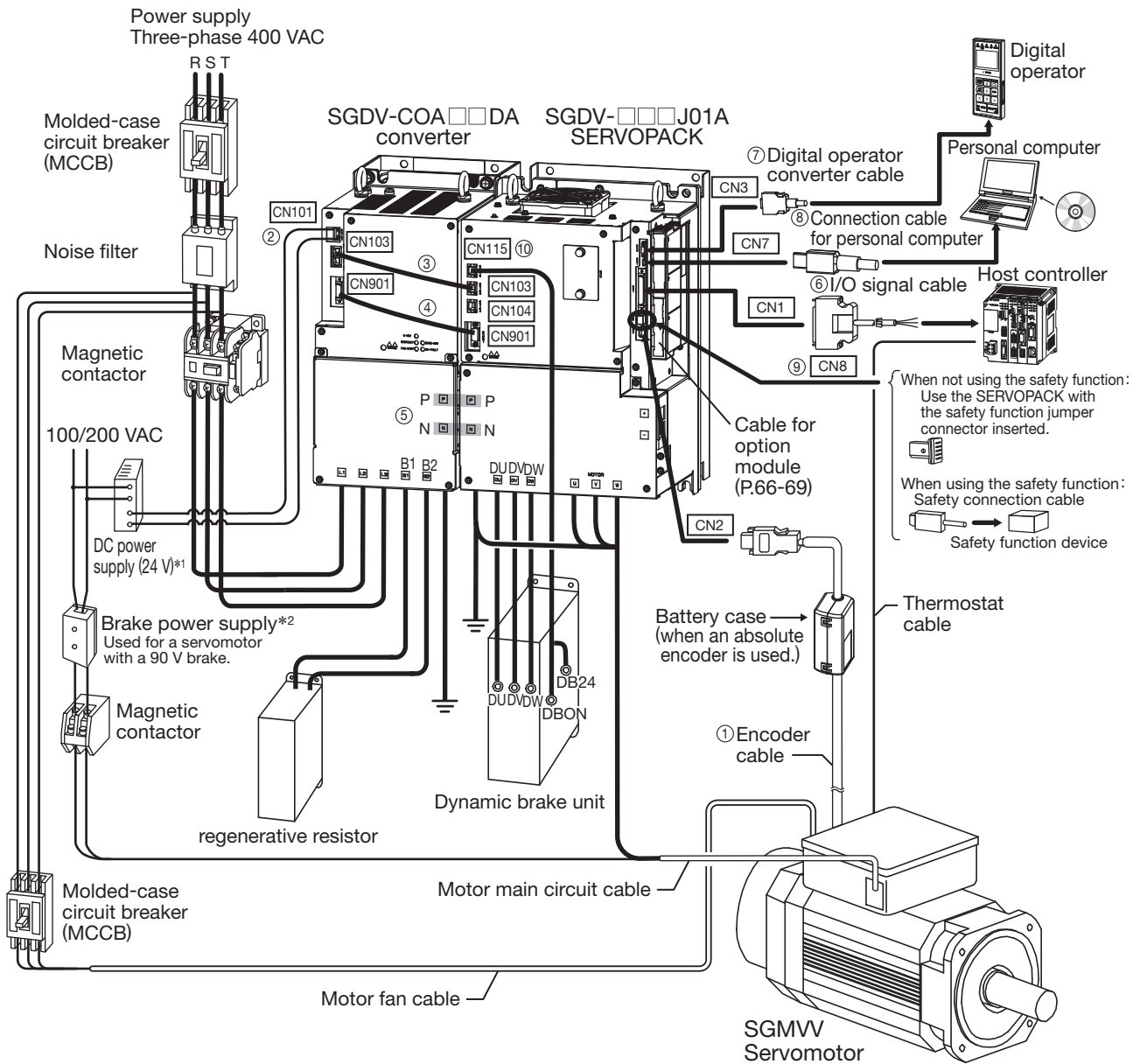

*1 : You must provide the 24-VDC power supply. Use a 24-VDC power supply with double insulation or reinforced insulation.

*2 : Use a 24-VDC power supply (not included).

If using a 90-VDC power supply for a brake, however, use one of the following power supplies.

•For 200-V input voltage: LPSE-2H01-E

•For 100-V input voltage: LPDE-1H01-E

For details, contact your Yaskawa representative or a Yaskawa sales department.

Note: Yaskawa does not provide the following cables.

- Motor main circuit cable (between SERVOPACK and servomotor)
- Motor fan cable (between power supply and servomotor)
- Regenerative resistor cable (between converter and regenerative resistor)
- Dynamic brake unit cable (between DU, DV, and DW terminals on SERVOPACK and DU, DV, and DW terminals on dynamic brake unit)

● When Using MECHATROLINK-II Communications References

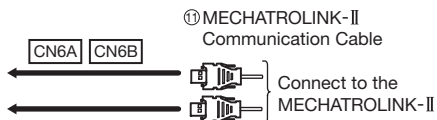

● When Using MECHATROLINK-III Communications References

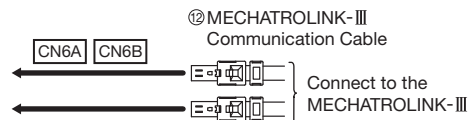

Selecting Cables

● Motor Main Circuit Cable

Yaskawa does not provide the cables. Check the terminal screw sizes on the motor's terminal box and *SERVOPACK Main Circuit Wire* and obtain suitable materials.

Servomotor Model SGMVV-	2B□□B 3Z□□B 3G□□B	2B□□D	4ED□B 5ED□B	3Z□□D 3G□□D 4ED□D																														
Part locations inside terminal box on model without brake (Units: mm)	<table border="1"> <thead> <tr> <th>Symbol</th> <th>Terminal</th> <th>Terminal Screw</th> </tr> </thead> <tbody> <tr> <td>U,V,W</td> <td>Motor</td> <td>M10</td> </tr> <tr> <td>⊕</td> <td>Ground</td> <td>M10</td> </tr> <tr> <td>1,1b</td> <td>Thermostat</td> <td>M4</td> </tr> </tbody> </table>	Symbol	Terminal	Terminal Screw	U,V,W	Motor	M10	⊕	Ground	M10	1,1b	Thermostat	M4		<table border="1"> <thead> <tr> <th>Symbol</th> <th>Terminal</th> <th>Terminal Screw</th> </tr> </thead> <tbody> <tr> <td>U,V,W</td> <td>Motor</td> <td>M10</td> </tr> <tr> <td>⊕</td> <td>Ground</td> <td>M10</td> </tr> <tr> <td>1,1b</td> <td>Thermostat</td> <td>M4</td> </tr> </tbody> </table>	Symbol	Terminal	Terminal Screw	U,V,W	Motor	M10	⊕	Ground	M10	1,1b	Thermostat	M4							
Symbol	Terminal	Terminal Screw																																
U,V,W	Motor	M10																																
⊕	Ground	M10																																
1,1b	Thermostat	M4																																
Symbol	Terminal	Terminal Screw																																
U,V,W	Motor	M10																																
⊕	Ground	M10																																
1,1b	Thermostat	M4																																
Part locations inside terminal box on model with brake (Units: mm)	<table border="1"> <thead> <tr> <th>Symbol</th> <th>Terminal</th> <th>Terminal Screw</th> </tr> </thead> <tbody> <tr> <td>U,V,W</td> <td>Motor</td> <td>M10</td> </tr> <tr> <td>⊕</td> <td>Ground</td> <td>M10</td> </tr> <tr> <td>1,1b</td> <td>Thermostat</td> <td>M4</td> </tr> <tr> <td>A,B</td> <td>Brake</td> <td>M4</td> </tr> </tbody> </table>	Symbol	Terminal	Terminal Screw	U,V,W	Motor	M10	⊕	Ground	M10	1,1b	Thermostat	M4	A,B	Brake	M4		<table border="1"> <thead> <tr> <th>Symbol</th> <th>Terminal</th> <th>Terminal Screw</th> </tr> </thead> <tbody> <tr> <td>U,V,W</td> <td>Motor</td> <td>M10</td> </tr> <tr> <td>⊕</td> <td>Ground</td> <td>M10</td> </tr> <tr> <td>1,1b</td> <td>Thermostat</td> <td>M4</td> </tr> <tr> <td>A,B</td> <td>Brake</td> <td>M4</td> </tr> </tbody> </table>	Symbol	Terminal	Terminal Screw	U,V,W	Motor	M10	⊕	Ground	M10	1,1b	Thermostat	M4	A,B	Brake	M4	
Symbol	Terminal	Terminal Screw																																
U,V,W	Motor	M10																																
⊕	Ground	M10																																
1,1b	Thermostat	M4																																
A,B	Brake	M4																																
Symbol	Terminal	Terminal Screw																																
U,V,W	Motor	M10																																
⊕	Ground	M10																																
1,1b	Thermostat	M4																																
A,B	Brake	M4																																

● Motor Fan Cable

Yaskawa does not specify the cables. Use appropriate cables for the connectors. The connectors specified by Yaskawa are required. Note that the connectors vary depending on the operation environment of servomotors. Two types of connectors are available.

Notes: 1 To conform with CE Marking, plugs and cable clamps with CE Marking are required.
2 For the specifications of the cooling fan, refer to page 9.

· Standard connectors

Servomotor-end Connector (Receptacle)	Cable-end Connectors (Not provided by Yaskawa)		
	Straight Plug	L-shaped Plug	Cable Clamp
CE05-2A18-10PD-D (MS3102A18-10P)	MS3106B18-10S	MS3108B18-10S	MS3057-10A







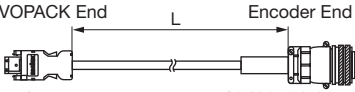
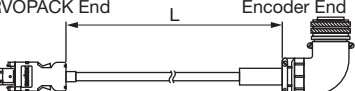
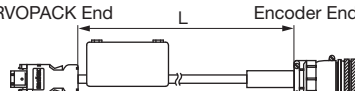

Notes: 1 Servomotor-end connectors (receptacles) are RoHS-compliant. Contact the respective connector manufacturers for RoHS-compliant cable-end connectors (not provided by Yaskawa).
2 Servomotor-end connectors (receptacles) can be used with MS plugs. For the model number of the MS receptacle, refer to the receptacle number in parentheses and select the appropriate plug.

· Protective Structure IP67 and European Safety Standards Compliant Connectors

Servomotor-end Connector (Receptacle)	Cable-end Connectors (Not provided by Yaskawa)				
	Straight Plug	L-shaped Plug	Cable Clamp	Applicable Cable Diameter (For Reference)	Manufacturer
CE05-2A18-10PD-D	CE05-6A18-10SD-D-BSS	CE05-8A18-10SD-D-BAS	CE3057-10A-1-D	10.5 dia. to 14.1 dia.	DDK Ltd.
			CE3057-10A-2-D	8.5 dia. to 11.0 dia.	
			CE3057-10A-3-D	6.5 dia. to 8.7 dia.	

Selecting Cables

●Encoder Cables (Max. length: 20 m)

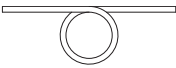
No.	Name	Length	Type		Specifications	Details	
			Standard Type	Flexible Type*			
①	Encoder Cables with Connectors (For Incremental Encoder, Straight Plug)	3 m	JZSP-CMP01-03-E	JZSP-CMP11-03-E	 <p>SERVOPACK End L Encoder End</p> <p>Connector (Crimped) (Molex Japan LLC)</p> <p>MS3106B20-29S (DDK Ltd.) Cable clamp model: MS3057-12A</p>	(1)	
		5 m	JZSP-CMP01-05-E	JZSP-CMP11-05-E			
		10 m	JZSP-CMP01-10-E	JZSP-CMP11-10-E			
		15 m	JZSP-CMP01-15-E	JZSP-CMP11-15-E			
		20 m	JZSP-CMP01-20-E	JZSP-CMP11-20-E			
	Encoder Cables with Connectors (For Incremental Encoder, L-shaped Plug)	3 m	JZSP-CMP02-03-E	JZSP-CMP12-03-E	 <p>SERVOPACK End L Encoder End</p> <p>Connector (Crimped) (Molex Japan LLC)</p> <p>MS3108B20-29S (DDK Ltd.) Cable clamp model: MS3057-12A</p>	(1)	
		5 m	JZSP-CMP02-05-E	JZSP-CMP12-05-E			
		10 m	JZSP-CMP02-10-E	JZSP-CMP12-10-E			
		15 m	JZSP-CMP02-15-E	JZSP-CMP12-15-E			
		20 m	JZSP-CMP02-20-E	JZSP-CMP12-20-E			
	Encoder Cables with Connectors (For Absolute Encoder, with a Battery Case, Straight Plug)	3 m	JZSP-CSP06-03-E	JZSP-CSP26-03-E	 <p>SERVOPACK End L Encoder End</p> <p>Connector (Crimped) (Molex Japan LLC)</p> <p>Battery Case (Battery Attached)</p> <p>MS3106B20-29S (DDK Ltd.) Cable clamp model: MS3057-12A</p>	(2)	
		5 m	JZSP-CSP06-05-E	JZSP-CSP26-05-E			
		10 m	JZSP-CSP06-10-E	JZSP-CSP26-10-E			
		15 m	JZSP-CSP06-15-E	JZSP-CSP26-15-E			
		20 m	JZSP-CSP06-20-E	JZSP-CSP26-20-E			
	Encoder Cables with Connectors (For Absolute Encoder, with a Battery Case, L-shaped Plug)	3 m	JZSP-CSP07-03-E	JZSP-CSP27-03-E	 <p>SERVOPACK End L Encoder End</p> <p>Connector (Crimped) (Molex Japan LLC)</p> <p>Battery Case (Battery Attached)</p> <p>MS3108B20-29S (DDK Ltd.) Cable clamp model: MS3057-12A</p>	(2)	
		5 m	JZSP-CSP07-05-E	JZSP-CSP27-05-E			
		10 m	JZSP-CSP07-10-E	JZSP-CSP27-10-E			
		15 m	JZSP-CSP07-15-E	JZSP-CSP27-15-E			
		20 m	JZSP-CSP07-20-E	JZSP-CSP27-20-E			
	SERVOPACK-end Connector Kit		JZSP-CMP9-1-E		 <p>Soldered</p> <p>(Molex Japan LLC)</p>	(3)	
Standard Encoder-end Connectors (Servomotor Connector: MS3102A20-29P)			MS3106B20-29S		Straight Plug		
			MS3108B20-29S		L-shaped Plug		
			MS3057-12A		Cable Clamp		
Encoder-end Connectors for Protective Structure IP67 (Servomotor Connector: 97F3102E20-29P)			JA06A-20-29S-J1-EB		Straight Plug		-
			JA08A-20-29S-J1-EB		L-shaped Plug		
			JL04-2022CKE (09) Diameter: 6.5 dia. to 9.5 dia.		Cable Clamp		
			JL04-2022CKE (12) Diameter: 9.5 dia. to 13 dia.				
Cables	5 m	JZSP-CMP09-05-E	JZSP-CSP39-05-E			(4)	
	10 m	JZSP-CMP09-10-E	JZSP-CSP39-10-E				
	15 m	JZSP-CMP09-15-E	JZSP-CSP39-15-E				
	20 m	JZSP-CMP09-20-E	JZSP-CSP39-20-E				

* : Use flexible cables for movable sections such as robot arms.

Selecting Cables

● Extension Encoder Cables (For extending from 30 m to 50 m)

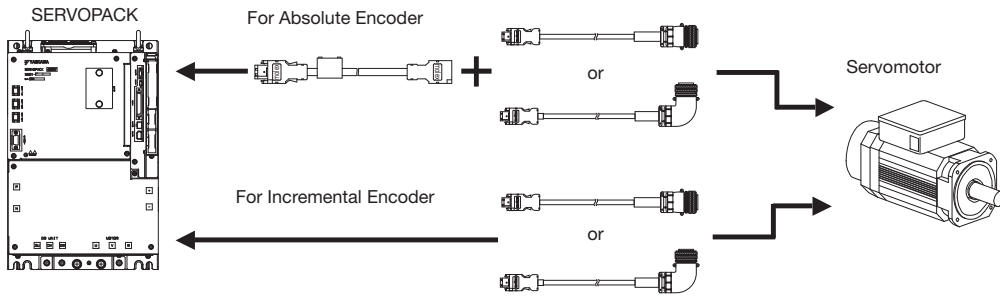



No.	Name	Length	Type	Specifications	Details	
①	Encoder Cables with Connectors (For Incremental and Absolute Encoder, Straight Plug)	30 m	JZSP-UCMP01-30-E	 SERVOPACK End L Encoder End Connector (Crimped) (Molex Japan LLC) MS3106B20-29S (DDK Ltd.) Cable clamp model: MS3057-12A	(5)	
		40 m	JZSP-UCMP01-40-E			
		50 m	JZSP-UCMP01-50-E			
	Encoder Cable with Connectors (For Incremental and Absolute Encoder, L-shaped Plug)	30 m	JZSP-UCMP02-30-E	 SERVOPACK End L Encoder End Connector (Crimped) (Molex Japan LLC) MS3108B20-29S (DDK Ltd.) Cable clamp model: MS3057-12A	(5)	
		40 m	JZSP-UCMP02-40-E			
		50 m	JZSP-UCMP02-50-E			
	Encoder Cable with a Battery Case (Required when an absolute encoder is used.)*	0.3 m	JZSP-CSP12-E	 SERVOPACK End 0.3 m Encoder End Connector (Crimped) (Molex Japan LLC) Battery Case (Battery Attached) Socket Contact (Soldered) (Molex Japan LLC)	(6)	
	Standard Encoder-end Connectors (Servomotor Connector: MS3102A20-29P)		MS3106B20-29S	Straight Plug		-
			MS3108B20-29S	L-shaped Plug		
			MS3057-12A	Cable Clamp		
Encoder-end Connectors for Protective Structure IP67 and European Safety Standards Compliant (Servomotor Connector: 97F3102E20-29P)		JA06A-20-29S-J1-EB	Straight Plug		-	
		JA08A-20-29S-J1-EB	L-shaped Plug			
		JL04-2022CKE (09) Diameter: 6.5 dia. to 9.5 dia. JL04-2022CKE (12) Diameter: 9.5 dia. to 13 dia. JL04-2022CKE (14) Diameter: 12.9 dia. to 15.9 dia.	Cable Clamp			
Extension Cables	30 m	JZSP-CMP19-30-E			(7)	
	40 m	JZSP-CMP19-40-E				
	50 m	JZSP-CMP19-50-E				

* : Not required when connecting a battery to the host controller.



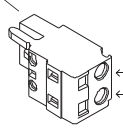

Selecting Cables

●Connectors for Control Power Cables

No.	Name	Length	Type	Specifications	Details												
②	CN101 Connector	—	Contact the WAGO Company of Japan., Ltd. Model: 231-202/026-000	<p>To Converter</p>  <table border="1"> <thead> <tr> <th rowspan="2">Connector Pin No.</th> <th colspan="2">SERVOPACK</th> </tr> </thead> <tbody> <tr> <td>2</td> <td>400V SGDV-COA□□DA</td> <td>200V SGDV-COA□□AA</td> </tr> <tr> <td>1</td> <td>+24V</td> <td>200VAC</td> </tr> <tr> <td></td> <td>0V</td> <td></td> </tr> </tbody> </table> <p>Note: For 400-V SERVOPACKs, be sure to connect with correct polarities.</p>	Connector Pin No.	SERVOPACK		2	400V SGDV-COA□□DA	200V SGDV-COA□□AA	1	+24V	200VAC		0V		—
	Connector Pin No.	SERVOPACK															
2		400V SGDV-COA□□DA	200V SGDV-COA□□AA														
1	+24V	200VAC															
	0V																
	Push Button	—	Contact the WAGO Company of Japan., Ltd. Model: 231-131		—												

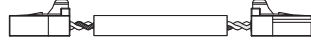





Note: The converter includes the connectors and the push buttons.

●Connection Cables between SERVOPACK and Converter (Same for All Models)

No.	Name	Length	Type	Specifications	Details
③	CN103 CN104 Control Power Cable between SERVOPACK and Converter (24 V)	0.4 m	JZSP-CVG00-A4-E		(8)
④	CN901 I/O Signal Cable between SERVOPACK and Converter	0.4 m	JZSP-CVI02-A4-E		(9)
⑤	Busbars Note: The busbars are included with the converter. The busbars connect the P and N terminals between the SERVOPACK and converter.	—	JZSP-CVB02-02-E	<ul style="list-style-type: none"> · For SGDV-COA2BAA · For SGDV-COA3ZDA  <p>Sold in set of two.</p>	—
		—	JZSP-CVB02-01-E	<ul style="list-style-type: none"> · For SGDV-COA3GAA · For SGDV-COA5EDA  <p>Sold in set of two.</p>	

Selecting Cables

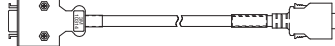
● Analog Voltage/Pulse Train Reference SERVOPACKS

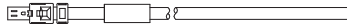
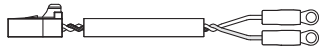
No.	Name	Length	Type	Specifications	Details	
⑥	CN1 I/O Signal Cables	Connector Kit		JZSP-CSI9-1-E	Soldered 	(10)
		Connector Terminal Converter Units	0.5 m	JUSP-TA50PG-E	Terminal Block and Connection Cable 	(11)
			1 m	JUSP-TA50PG-1-E		
			2 m	JUSP-TA50PG-2-E		
		Cables with Loose Wires at One End	1 m	JZSP-CSI01-1-E	Cable with Loose Wires at Peripheral Devices 	(12)
			2 m	JZSP-CSI01-2-E		
3 m	JZSP-CSI01-3-E					
⑦	CN3	Digital Operator		JUSP-OP05A-1-E	With Connection Cable (1 m) 	(13)
		Digital Operator Converter Cable*1	0.3 m	JZSP-CVS05-A3-E	Cable with Connectors at Both Ends 	(14)
⑧	CN7 Connection Cables for Personal Computer*2	2.5 m	JZSP-CVS06-02-E	Cable with Connectors at Both Ends 	(16)	
—	CN5 Cable for Analog Monitor	1 m	JZSP-CA01-E	SERVOPACK End 	(17)	
⑨	CN8 Cables for Safety Function Device	Cables with Connector*3	1 m	JZSP-CVH03-01-E	SERVOPACK End 	(18)
		3 m	JZSP-CVH03-03-E			
		Connector Kit*4		Contact Tyco Electronics Japan G.K. Product name: INDUSTRIAL MINI I/O D-SHAPE TYPE1 PLUG CONNECTOR KIT Model: 2013595-1		
⑩	CN115 Dynamic Brake Unit Connection Cables	1.5 m	JZSP-CVD00-1A5-E	SERVOPACK End 	(19)	
		3 m	JZSP-CVD00-03-E			

*1 : A converter cable is required to use Σ -III series digital operators (model: JUSP-OP05A) for Σ -V series SERVOPACKs.

*2 : For connection to a personal computer, use a cable specified by Yaskawa. If not, operation cannot be guaranteed.









*3 : When using the safety function, connect this cable to the safety devices.

Even when not using the safety function, use SERVOPACKs with the Safe Jumper Connector (model: JZSP-CVH05-E) connected.

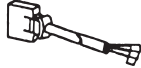
*4 : Use the connector kit when you make cables yourself.

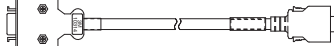
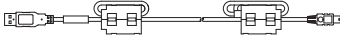
Selecting Cables

●MECHATROLINK-II Communications Reference SERVOPACKs

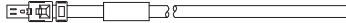
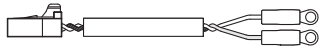
No.	Name	Length	Type	Specifications	Details	
⑥	I/O Signal Cables CN1	Connector Kit		JZSP-CSI9-1-E	Soldered 	(10)
		Connector Terminal Converter Units	0.5 m	JZSP-TA50PG-E	Terminal Block and Connection Cable 	(11)
			1 m	JZSP-TA50PG-1-E		
			2 m	JZSP-TA50PG-2-E		
		Cables with Loose wire at One End	1 m	JZSP-CSI01-1-E	Cable with Loose Wires at Peripheral Devices 	(12)
			2 m	JZSP-CSI01-2-E		
3 m	JZSP-CSI01-3-E					
⑦	Digital Operator CN3	Digital Operator		JZSP-OP05A-1-E	With Connection Cable (1 m) 	(13)
		Digital Operator Converter Cable*1	0.3 m	JZSP-CVS05-A3-E	Cable with Connectors at Both Ends 	(14)
⑧	Connection Cables for Personal Computer*2 CN7	2.5 m	JZSP-CVS06-02-E	Cable with Connectors at Both Ends 	(16)	
⑪	MECHATROLINK-II Communication Cables*3 CN6A CN6B	Cables with Connectors at Both Ends	0.5 m to 50 m	JEPMC-W6002-□□-E		(20)
		Cables with Connectors at Both Ends (with Ferrite Core)	0.5 m to 50 m	JEPMC-W6003-□□-E		(21)
		Terminator		JEPMC-W6022-E		(22)
—	Cable for Analog Monitor CN5	1 m	JZSP-CA01-E	SERVOPACK End 	(17)	
⑨	Cable for Safety Function Device CN8	Cables with Connector*4	1 m	JZSP-CVH03-01-E	SERVOPACK End 	(18)
		3 m	JZSP-CVH03-03-E			
		Connector kit*5	Contact Tyco Electronics Japan G.K. Product name: INDUSTRIAL MINI I/O D-SHAPE TYPE1 PLUG CONNECTOR KIT Model: 2013595-1			
⑩	Dynamic Brake Unit Connection Cables CN115	1.5 m	JZSP-CVD00-1A5-E	SERVOPACK End 	(19)	
		3 m	JZSP-CVD00-03-E			

*1 : A converter cable is required to use Σ -III series digital operators (model: JZSP-OP05A) for Σ -V series SERVOPACKs.

*2 : For connection to a personal computer, use a cable specified by Yaskawa. If not, operation cannot be guaranteed.

*3 : Use a MECHATROLINK-II communications cable specified by Yaskawa. When using other cables, noise resistance may be reduced, and operation cannot be guaranteed.









*4 : When using the safety function, connect this cable to the safety devices.

Even when not using the safety function, use SERVOPACKs with the Safe Jumper Connector (model: JZSP-CVH05-E) connected.

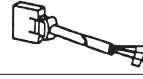
*5 : Use the connector kit when you make cables yourself.

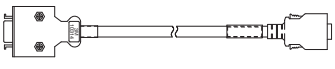
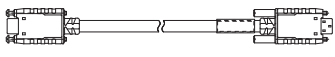
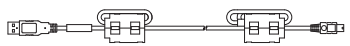
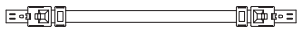
Selecting Cables

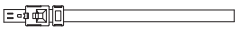
●MECHATROLINK-III Communications Reference SERVOPACKS

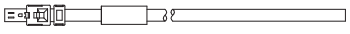
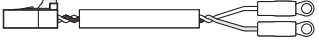
No.	Name	Length	Type	Specifications	Details	
⑥	<div style="border: 1px solid black; padding: 2px;">CN1</div> I/O Signal Cables	Connector Kit		JZSP-CSI9-1-E	Soldered 	(10)
		Connector Terminal Converter Units	0.5 m	JUSP-TA50PG-E	Terminal Block and Connection Cable 	(11)
			1 m	JUSP-TA50PG-1-E		
			2 m	JUSP-TA50PG-2-E		
		Cables with Loose wire at One End	1 m	JZSP-CSI01-1-E	Cable with Loose Wires at Peripheral Devices 	(12)
			2 m	JZSP-CSI01-2-E		
3 m	JZSP-CSI01-3-E					
⑦	<div style="border: 1px solid black; padding: 2px;">CN3</div>	Digital Operator		JUSP-OP05A-1-E	With Connection Cable (1 m) 	(13)
		Digital Operator Converter Cables	0.3 m	JZSP-CVS05-A3-E*1	Cable with Connectors at Both Ends 	(14)
				JZSP-CVS07-A3-E*2	With Lock Screws 	(15)
⑧	<div style="border: 1px solid black; padding: 2px;">CN7</div> Connection Cables for Personal Computer*3	2.5 m	JZSP-CVS06-02-E	Cable with Connectors at Both Ends 	(16)	
⑫	<div style="border: 1px solid black; padding: 2px;">CN6A</div> <div style="border: 1px solid black; padding: 2px;">CN6B</div> MECHATROLINK-III Communication Cables*4	Cables with Connectors at Both Ends	0.2 m to 50 m	JEPMC-W6012-□□-E		(23)
		Cables with Connectors at Both Ends (With Ferrite Core)	10 m to 50 m	JEPMC-W6013-□□-E		(24)
		Cables with Loose Wire at One End	0.5 m to 50 m	JEPMC-W6014-□□-E		(25)
—	<div style="border: 1px solid black; padding: 2px;">CN5</div> Cable for Analog Monitor	1 m	JZSP-CA01-E	SERVOPACK End 	(17)	
⑨	<div style="border: 1px solid black; padding: 2px;">CN8</div> Cables for Safety Function Device	Cables with Connector*5	1 m	JZSP-CVH03-01-E	SERVOPACK End 	(18)
			3 m	JZSP-CVH03-03-E		
		Connector kit*6		Contact Tyco Electronics Japan G.K. Product name: INDUSTRIAL MINI I/O D-SHAPE TYPE1 PLUG CONNECTOR KIT Model: 2013595-1		
⑩	<div style="border: 1px solid black; padding: 2px;">CN115</div> Dynamic Brake Unit Connection Cables	1.5 m	JZSP-CVD00-1A5-E	SERVOPACK End 	(19)	
		3 m	JZSP-CVD00-03-E			

*1 : A converter cable is required to use Σ -III series digital operators (model: JUSP-OP05A) for Σ -V series SERVOPACKS.

*2 : A converter cable is required when connecting the digital operator cable while using MECHATROLINK-III Communications SERVOPACK.

*3 : For connection to a personal computer, use a cable specified by Yaskawa. If not, operation cannot be guaranteed.

*4 : Use a MECHATROLINK-III communications cable specified by Yaskawa. When using other cables, noise resistance may be reduced, and operation cannot be guaranteed.

*5 : When using the safety function, connect this cable to the safety devices.

Even when not using the safety function, use SERVOPACKS with the Safe Jumper Connector (model: JZSP-CVH05-E) connected.

*6 : Use the connector kit when you make cables yourself.

Details of Cables

(1) Wiring Specifications for Encoder Cable with Connectors (For incremental encoder)

SERVOPACK End		Encoder (Servomotor) End			
Pin No.	Signal	Pin No.	Wire Color		
			Standard Type	Flexible Type	
5	PS	C	Light blue	Red/light blue	
6	/PS	D	Light blue/white	Black/light blue	
2	PG 0V	G	Black	Green	
1	PG 5V	H	Red	Orange	
4	BAT (-)	S	Orange/white	Black/pink	
3	BAT (+)	T	Orange	Red/pink	
Shell	FG	J	FG	FG	

Note: The signals BAT (+) and BAT (-) are used when using an absolute encoder.

(2) Wiring Specifications for Encoder Cable with Connectors (For absolute encoder, with a battery case)

SERVOPACK End		Encoder (Servomotor) End			
Pin No.	Signal	Pin No.	Wire Color		
			Standard Type	Flexible Type	
5	PS	C	Light blue	Red/pink	
6	/PS	D	Light blue/white	Black/pink	
2	PG 0V	G	Black	Green	
1	PG 5V	H	Red	Orange	
4	BAT (-)	S	Orange/white	Black/light blue	
3	BAT (+)	T	Orange	Red/light blue	
Shell	FG	J	FG	FG	

Battery Case	
Pin No.	Signal
2	BAT (-)
1	BAT (+)

(3) SERVOPACK-end Connector Kit Specifications

Type	JZSP-CMP9-1-E
Manufacturer	Molex Japan LLC
Connector Model (For standard)	55100-0670 (soldered)
External Dimensions (Units: mm)	

(4) Cable Specifications

Items	Standard Type	Flexible Type
Type*	JZSP-CMP09-□□-E	JZSP-CSP39-□□-E
Cable Length	20 m max.	
Specifications	UL20276 (Rating temperature: 80°C) AWG22×2C+AWG24×2P AWG22 (0.33 mm ²) Outer diameter of insulating sheath: 1.15 dia. AWG24 (0.20 mm ²) Outer diameter of insulating sheath: 1.09 dia.	UL20276 (Rating temperature: 80°C) AWG22×2C+AWG24×2P AWG22 (0.33 mm ²) Outer diameter of insulating sheath: 1.35 dia. AWG24 (0.20 mm ²) Outer diameter of insulating sheath: 1.21 dia.
Finished Dimensions	6.5 dia.	6.8 dia.
Internal Configuration and Lead Color		
Yaskawa Standards Specifications (Standard Length)	Cable length: 5 m, 10 m, 15 m, 20 m	

*: Specify the cable length in □□.
Example: JZSP-CMP09-05-E (5 m)

(5) Wiring Specifications for Encoder Cable with Connectors (For incremental and absolute encoder)

SERVOPACK End		Encoder (Servomotor) End			
Pin No.	Signal	Pin No.	Wire Color		
			Standard Type	Flexible Type	
5	PS	C	Light blue	Red/light blue	
6	/PS	D	Light blue/white	Black/light blue	
2	PG 0V	G	Black	Green	
1	PG 5V	H	Red	Orange	
4	BAT (-)	S	Orange/white	Black/pink	
3	BAT (+)	T	Orange	Red/pink	
Shell	FG	J	FG	FG	

Note: The signals BAT (+) and BAT (-) are used when using an absolute encoder.

(6) Wiring Specifications for Encoder Cable with a Battery Case (For absolute encoder)

SERVOPACK End		Encoder (Servomotor) End	
Pin No.	Signal	Pin No.	Wire Color
6	/PS	6	Light blue/white
5	PS	5	Light blue
4	BAT (-)	4	Orange/white
3	BAT (+)	3	Orange
2	PG 0V	2	Black
1	PG 5V	1	Red
Shell	FG	Shell	FG

Battery Case	
Pin No.	Signal
2	BAT (-)
1	BAT (+)

(7) Cable Specifications

Type*	JZSP-CMP19-□□-E
Cable Length	50 m max.
Specifications	UL20276 (Rating temperature: 80°C) AWG16×2C+AWG26×2P AWG16 (1.31 mm ²) Outer diameter of insulating sheath: 2.0 dia. AWG26 (0.13 mm ²) Outer diameter of insulating sheath: 0.91 dia.
Finished Dimensions	6.8 dia.
Internal Configuration and Lead Colors	
Yaskawa Standard Specifications (Standard Length)	Cable length: 30 m, 40 m, 50 m

*: Specify the cable length in □□.
Example: JZSP-CMP19-30-E (30 m)

(8) Control Power Cable between SERVOPACK and Converter (24 V) for CN103/CN104 (Model: JZSP-CVG00-A4-E)

External Dimensions (Units: mm)

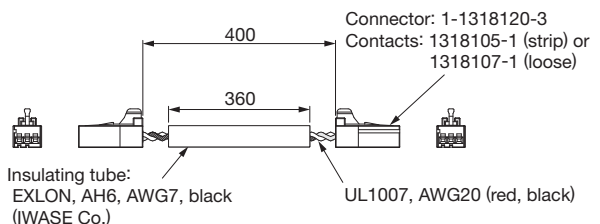

Converter End		SERVOPACK End	
Pin No.	Signal	Pin No.	Wire Color
1	P24	1	Red
2	-	2	-
3	N24	3	Black

Details of Cables

(9) I/O Signal Cable between SERVOPACK and Converter for CN901 (Model: JZSP-CVI02-A4-E)

External Dimensions (Units: mm)

Connector (9-pin) for converter: HDEB-9P (05)* (soldered) or CDE-9P (05)* (crimped)
 Contacts: CD-PC-121* (loose) or CD-PC-221* (lead)
 Shell: HDE-CTH (4-40) (10)*
 *: Manufactured by Hirose Electric Co., Ltd.

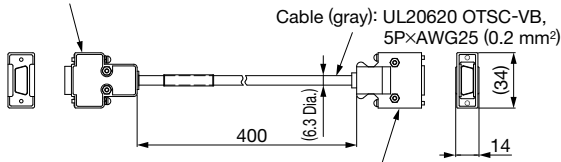

Connector (20-pin) for SERVOPACK: 10120-3000PE (3M Japan Ltd.)
 Shell: 10320-52AO-008

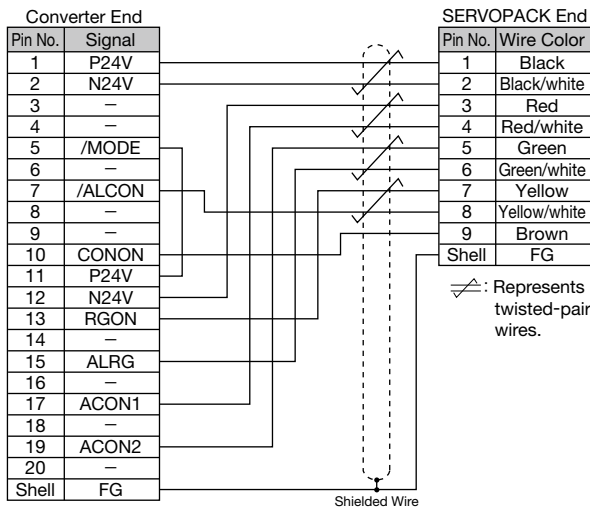

(10) Connector Kit for CN1

Use the following connector and cable to assemble the cable.
 The CN1 connector kit includes one case and one connector.

Connector Kit Model	Case		Connector	
	Model	Qty	Model	Qty
JZSP-CSI9-1-E	10350-52Z0-008*	1 set	10150-3000PE* (Soldered)	1

* : Manufactured by 3M Japan Ltd.

Cable Size

Item	Specifications
Cable	Use twisted-pair or twisted-pair shielded wire.
Applicable Wires	AWG24, 26, 28, 30
Cable Finished Diameter	16 dia. max.

External Dimensions of Case (Units: mm)

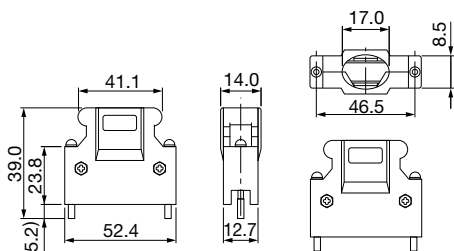

External Dimensions of Connector (Units: mm)

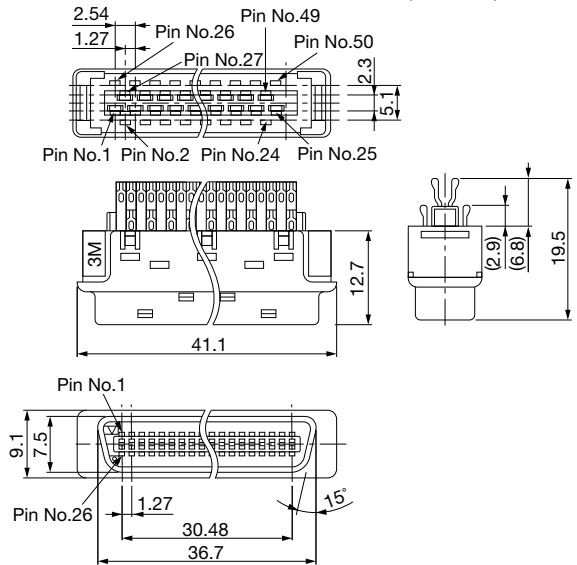

(11) Connector Terminal Converter Unit for CN1

Configurations

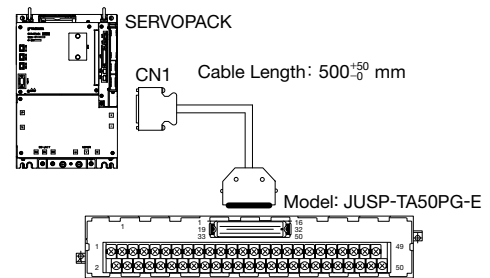

External Dimensions of Terminal Block (Units: mm)

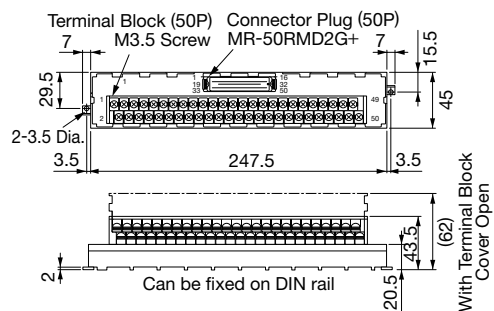

External Dimensions of Cable (Units: mm)

SERVOPACK End Connector (50P): 10150-6000EL (3M Japan Ltd.)
 Shell: 10350-52Z0-008 (3M Japan Ltd.)

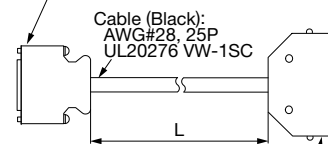

Terminal Converter Unit-end Connector (50P): MRP-50F01 (Honda Tsushin Kogyo Co., Ltd.)
 Case: MR-50L+ (Honda Tsushin Kogyo Co., Ltd.)

Note: The pin numbers in the SERVOPACK connector and the pin numbers in the terminal block are the same. If assembling cables, refer to ●Cable with Loose Wires at One End for CN1 Connection Diagram of JZSP-CSI01-□-E Cable on the next page.

Model	Cable Length (L)
JZSP-TA50PG-E	0.5 m
JZSP-TA50PG-1-E	1 m
JZSP-TA50PG-2-E	2 m

Details of Cables

(12) Cable with Loose Wires at One End for CN1

External Dimensions (Units: mm)

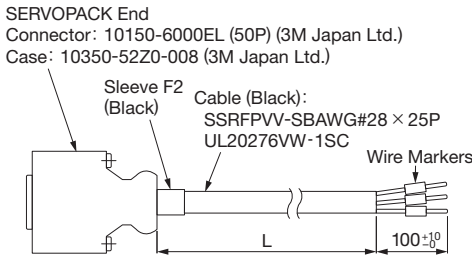

Model	Cable Length (L)
JZSP-CSI01-1-E	1 m
JZSP-CSI01-2-E	2 m
JZSP-CSI01-3-E	3 m

● Cable with Loose Wires at One End for CN1

Connection Diagram of JZSP-CSI01-□-E Cable

SERVOPACK End					Host Controller End	
Pin No.	Signal	Wire Color	Marking Color	Marking Dots		Lead Marker
1	SG	Orange	Red	1		1
3	PL1	Orange	Black	1		3
2	SG	Gray	Red	1		2
4	SEN	Gray	Black	1		4
5	V-REF	White	Red	1		5
6	SG	White	Black	1		6
7	PULS	Yellow	Red	1		7
8	/PULS	Yellow	Black	1		8
9	T-REF	Pink	Red	1		9
10	SG	Pink	Black	1		10
11	SIGN	Orange	Red	2		11
12	/SIGN	Orange	Black	2		12
13	PL2	Gray	Red	2		13
14	/CLR	White	Red	2		14
15	CLR	White	Black	2		15
16	-	Gray	Black	2		16
17	-	Yellow	Red	2		17
18	PL3	Yellow	Black	2		18
19	PCO	Pink	Red	2		19
20	/PCO	Pink	Black	2		20
21	BAT (+)	Orange	Red	3		21
22	BAT (-)	Orange	Black	3		22
23	-	Gray	Red	3		23
24	-	Gray	Black	3		24
25	/V-CMP+	White	Red	3		25
26	/V-CMP-	White	Black	3		26
27	/TGON+	Yellow	Red	3		27
28	/TGON-	Yellow	Black	3		28
29	/S-RDY+	Pink	Red	3		29
30	/S-RDY-	Pink	Black	3		30
31	ALM+	Orange	Red	4		31
32	ALM-	Orange	Black	4		32
33	PAO	Gray	Red	4		33
34	/PAO	Gray	Black	4		34
35	PBO	White	Red	4		35
36	/PBO	White	Black	4		36
37	ALO1	Yellow	Red	4		37
38	ALO2	Yellow	Black	4		38
39	ALO3	Pink	Red	4		39
40	/S-ON	Pink	Black	4		40
41	/P-CON	Orange	Red	5		41
42	P-OT	Orange	Black	5		42
43	N-OT	Gray	Red	5		43
44	/ALM-RST	Gray	Black	5		44
45	/P-CL	White	Red	5		45
46	/N-CL	White	Black	5		46
47	+24V-IN	Yellow	Red	5		47
48	-	Pink	Red	5		48
49	-	Pink	Black	5		49
50	-	Yellow	Black	5		50
Case	Shield					

⚡ : Represents twisted-pair wires.

(13) Digital Operator (Model: JUSP-OP05A-1-E)

(Units: mm)

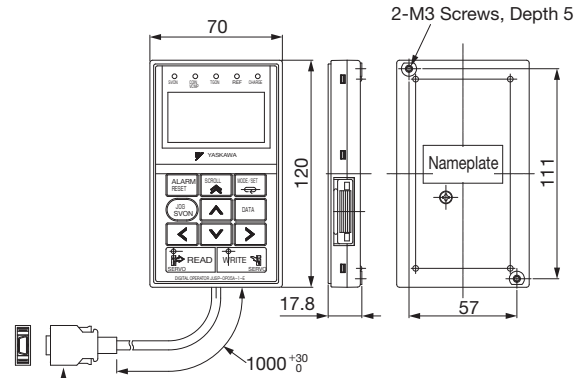

Connector: HDR-E14MAG1+ (Honda Tsushin Kogyo Co., Ltd.)
Case: HDR-E14LPA5 (Honda Tsushin Kogyo Co., Ltd.)

(14) Digital Operator Converter Cable for CN3 (Model: JZSP-CVS05-A3-E)

A converter cable is required to use Σ -III series digital operators (model: JUSP-OP05A) for Σ -V series SERVOPACKS.

External Dimensions (Units: mm)

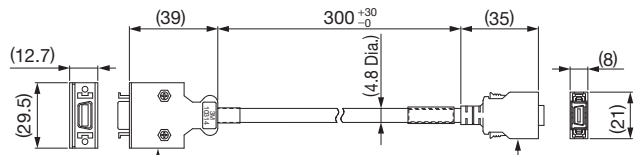

Connector (14-pole):
10214-6202PL
(3M Japan Ltd.)
Cover:
FA458036
(Yasco Components Co., Ltd.)

Connector (14-pole):
HDR-E14MAG1+
(Honda Tsushin Kogyo Co., Ltd.)
Cover:
HDR-E14LPA5
(Honda Tsushin Kogyo Co., Ltd.)

(15) Digital Operator Converter Cable for CN3 (Model: JZSP-CVS07-A3-E)

A converter cable is required when connecting the digital operator cable while using MECHATROLINK-III Communications SERVOPACK.

External Dimensions (Units: mm)

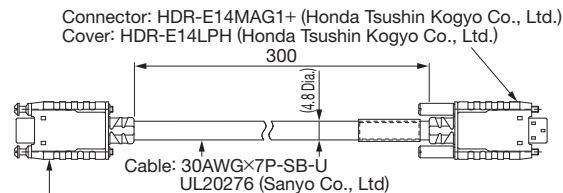

Connector: HDR-E14FAG1+ (Honda Tsushin Kogyo Co., Ltd.)
Cover: HDR-E14LPHD+ (Honda Tsushin Kogyo Co., Ltd.)

Details of Cables

(16) Connection Cable for Personal Computer for CN7 (Model: JZSP-CVS06-02-E)

· External Dimensions (Units: mm)

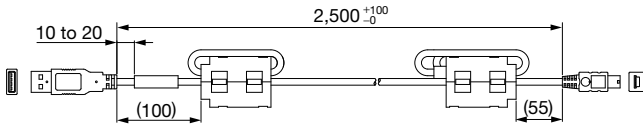

IMPORTANT

For connection to a personal computer, use a cable specified by Yaskawa. If not, operation cannot be guaranteed.

(17) Cable for Analog Monitor for CN5 (Model: JZSP-CA01-E)

· External Dimensions (Units: mm)

Socket: DF11-4DS-2C (Hirose Electric Co., Ltd.)
Contact: DF11-2428SCF (Hirose Electric Co., Ltd.)

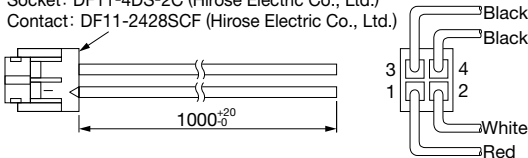

View from Cable End

· Specifications

Pin No.	Cable Color	Signal	Standard Settings
1	Red	Analog Monitor 2	Motor speed: 1V/1000 min ⁻¹
2	White	Analog Monitor 1	Torque reference: 1V/100% rated torque
3, 4	Black (2 cables)	GND (0V)	—

Note: The specifications above are factory settings. Monitor specifications can be changed by changing parameters Pn006 and Pn007.

(18) Cable for Safety Function Device for CN8 (Model: JZSP-CVH03-□□-E)

When using the safety function, connect this cable to the safety devices.

Even when not using the safety function, use SERVOPACKs with the Safe Jumper Connector (model: JZSP-CVH05-E) connected.

· External Dimensions (Units: mm)

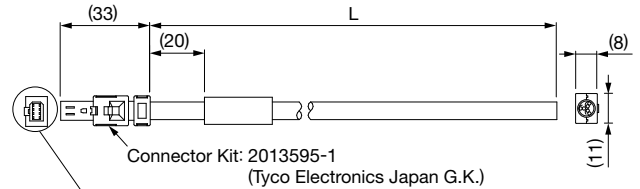

Pin Layout

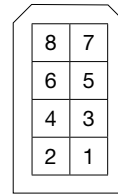

Model	Cable Length (L)
JZSP-CVH03-01-E	1 m
JZSP-CVH03-03-E	3 m

· Specifications

Pin No.	Signal	Lead Color	Marking Color
1	Not used	—	—
2	Not used	—	—
3	/HWBB1-	White	Black
4	/HWBB1+	White	Red
5	/HWBB2-	Gray	Black
6	/HWBB2+	Gray	Red
7	EDM1-	Orange	Black
8	EDM1+	Orange	Red

(19) Dynamic Brake Unit Connection Cable for CN115 (Model: JZSP-CVD00-□□-E)

· External Dimensions (Units: mm)

Connector: 2-1318120-3

Contacts: 1318105-1 (strip) or 1318107-1 (loose)

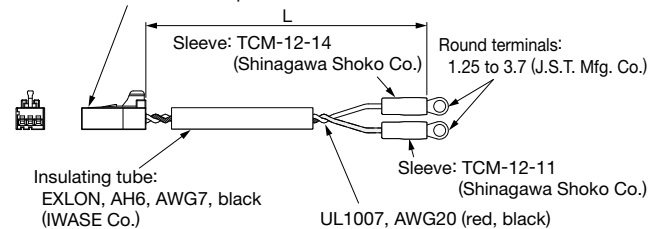

Model	Cable Length (L)
JZSP-CVD00-1A5-E	1.5 m
JZSP-CVD00-03-E	3 m

SERVOPACK End			DB Unit End
Pin No.	Signal	Wire Color	Terminal
1	DB24	Red	DB24
2	—	—	—
3	DBON	Black	DBON

Details of Cables

(20) MECHATROLINK-II Communication Cable for CN6A/CN6B (Model: JEPMC-W6002-□□-E)

· External Dimensions (Units: mm)



Model	Cable Length (L)
JEPMC-W6002-A5-E	0.5 m
JEPMC-W6002-01-E	1 m
JEPMC-W6002-03-E	3 m
JEPMC-W6002-05-E	5 m
JEPMC-W6002-10-E	10 m
JEPMC-W6002-20-E	20 m
JEPMC-W6002-30-E	30 m
JEPMC-W6002-40-E	40 m
JEPMC-W6002-50-E	50 m

(21) MECHATROLINK-II Communication Cable with Ferrite Core for CN6A/CN6B (Model: JEPMC-W6003-□□-E)

· External Dimensions (Units: mm)

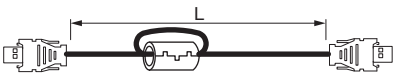

Model	Cable Length (L)
JEPMC-W6003-A5-E	0.5 m
JEPMC-W6003-01-E	1 m
JEPMC-W6003-03-E	3 m
JEPMC-W6003-05-E	5 m
JEPMC-W6003-10-E	10 m
JEPMC-W6003-20-E	20 m
JEPMC-W6003-30-E	30 m
JEPMC-W6003-40-E	40 m
JEPMC-W6003-50-E	50 m

IMPORTANT

Use a MECHATROLINK-II communications cable specified by Yaskawa. When using other cables, noise resistance may be reduced, and operation cannot be guaranteed.

(22) MECHATROLINK-II Communication Terminator for CN6A/CN6B (Model: JEPMC-W6022-E)

· External Dimensions (Units: mm)

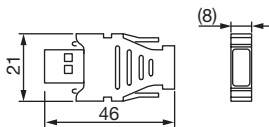

(23) MECHATROLINK-III Communication Cable for CN6A/CN6B (Model: JEPMC-W6012-□□-E)

· External Dimensions (Units: mm)

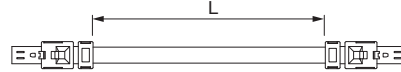

Model	Cable Length (L)
JEPMC-W6012-A2-E	0.2 m
JEPMC-W6012-A5-E	0.5 m
JEPMC-W6012-01-E	1 m
JEPMC-W6012-02-E	2 m
JEPMC-W6012-03-E	3 m
JEPMC-W6012-04-E	4 m
JEPMC-W6012-05-E	5 m
JEPMC-W6012-10-E	10 m
JEPMC-W6012-20-E	20 m
JEPMC-W6012-30-E	30 m
JEPMC-W6012-50-E	50 m

(24) MECHATROLINK-III Communication Cable with Ferrite Core for CN6A/CN6B (Model: JEPMC-W6013-□□-E)

· External Dimensions (Units: mm)

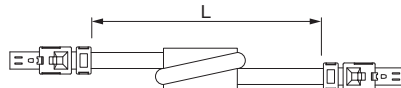

Model	Cable Length (L)
JEPMC-W6013-10-E	10 m
JEPMC-W6013-20-E	20 m
JEPMC-W6013-30-E	30 m
JEPMC-W6013-50-E	50 m

(25) MECHATROLINK-III Communication Cable with Loose Wire at One End for CN6A/CN6B (Model: JEPMC-W6014-□□-E)

· External Dimensions (Units: mm)

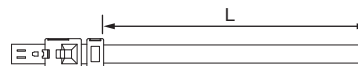

Model	Cable Length (L)
JEPMC-W6014-A5-E	0.5 m
JEPMC-W6014-01-E	1 m
JEPMC-W6014-03-E	3 m
JEPMC-W6014-05-E	5 m
JEPMC-W6014-10-E	10 m
JEPMC-W6014-30-E	30 m
JEPMC-W6014-50-E	50 m

IMPORTANT

Use a MECHATROLINK-III communications cable specified by Yaskawa. When using other cables, noise resistance may be reduced, and operation cannot be guaranteed.

Battery Case

● Battery Case (Model: JUSP-BA01-E)

Use this battery case if your battery case needs replacing due to damage etc.. This battery case cannot be used with an incremental encoder cable.

IMPORTANT

- 1 The battery case (JUSP-BA01-E) is not provided with a battery. A battery must be purchased separately.
- 2 Install the battery case where the ambient temperature is between 0°C to 55°C.

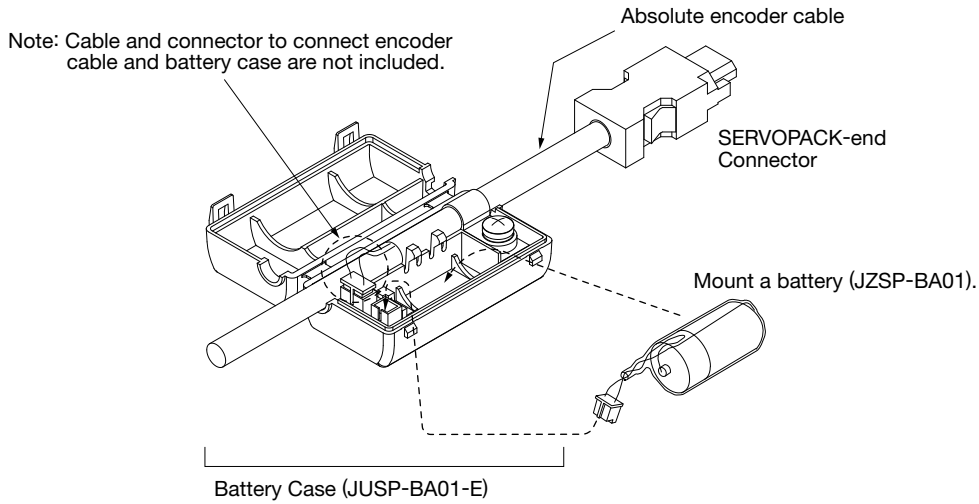

(1) Mounting a Battery in a Battery Case

Prepare a lithium battery (JZSP-BA01) and mount in a battery case.

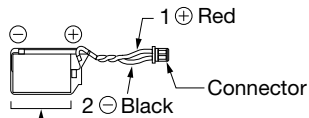

ER3 V Lithium Battery
(3.6 V, 1000 mAh, manufactured by Toshiba Battery Co., Ltd.)

(2) Connecting a Battery to the Host Controller

Use a battery that meets the specifications of the host controller. Use an ER6VC3N (3.6 V, 2000 mAh, manufactured by Toshiba Battery Co., Ltd.) or equivalent battery.

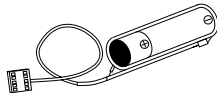

Cable for Safety Module (Option)

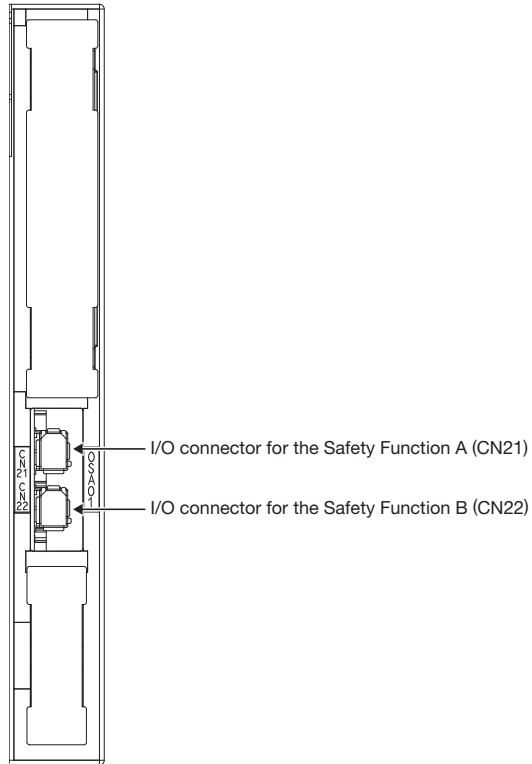

● Cable for Safety Module

Name	Length	Order No.	Specifications	Details
<div style="border: 1px solid black; padding: 2px;">CN21</div> <div style="border: 1px solid black; padding: 2px;">CN22</div> Cable for Safety Function Device	1 m	JZSP-CVH03-01-E		(a)
	3 m	JZSP-CVH03-03-E		
Connector Kit*2	Contact Tyco Electronics Japan G.K. Product name: Industrial Mini I/O D-shape Type1 Plug Connector Kit Model: 2013595-1			

*1 : When using the safety function, connect this cable to the safety devices.
 *2 : Use the connector kit when you make cables yourself.

● Details of Cable

(a) Cable with Connector for CN21 and CN22

· External Dimensions (Units: mm)

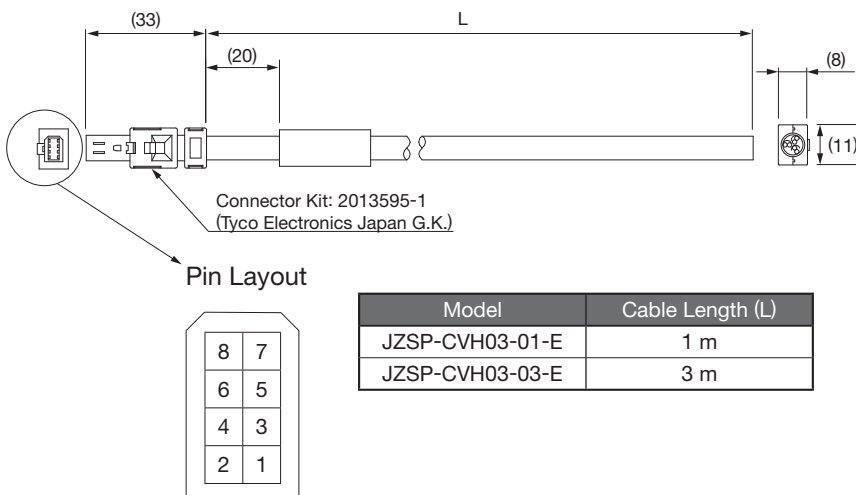

Model	Cable Length (L)
JZSP-CVH03-01-E	1 m
JZSP-CVH03-03-E	3 m

· Specifications

Pin No.	Signal	Lead Color	Marking Color
1	Not used	—	—
2	Not used	—	—
3	/SRI-□1-	White	Black
4	/SRI-□1+	White	Red
5	/SRI-□2-	Gray	Black
6	/SRI-□2+	Gray	Red
7	EDM-□-	Orange	Black
8	EDM-□+	Orange	Red

Note: The signal name varies in accordance with the connector used.
 Connector CN21: □=A
 Connector CN22: □=B

Cable for INDEXER Module (Option)

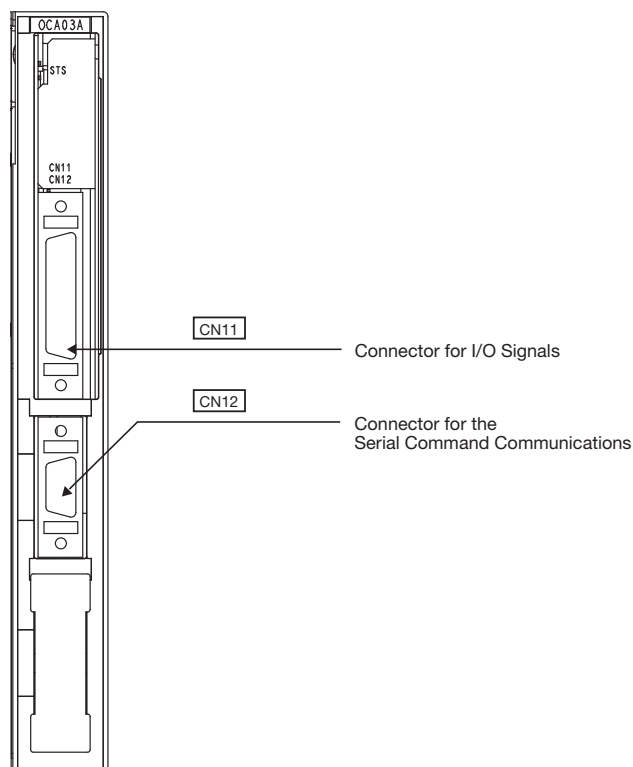

● Cables for INDEXER Module

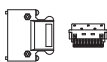
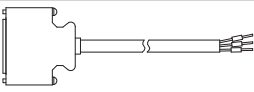
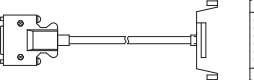
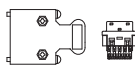
Name		Length	Order No.	Specifications	Details
CN11 Cable for I/O Signals	Connector Kit		DP9420007-E		(a)
	Cable with Loose wire at One End	1 m	JZSP-CVI01-1-E		(b)
		2 m	JZSP-CVI01-2-E		
		3 m	JZSP-CVI01-3-E		
	Cable with Terminal Block at One End	0.5 m	JUSP-TA36V-E		(c)
		1 m	JUSP-TA36V-1-E		
2 m		JUSP-TA36V-2-E			
CN12 Cable for Serial Command Communications	Connector kit*		JZSP-CHI9-1		(d)

* : Use the connector kit when you make cables yourself.

Cable for INDEXER Module (Option)

●Details of Cables

(a) Connector Kit for CN11

Use the following connector and cable to assemble the cable.
The CN11 connector kit includes one case and one connector.

Connector Kit Model	Case		Connector	
	Model	Qty	Model	Qty
DP9420007-E	10336-52A0-008*	1 set	10136-3000PE* (Soldered)	1

* : Manufactured by 3M Japan Ltd.

· Cable Size

Item	Specifications
Cable	Use twisted-pair or twisted-pair shielded wire.
Applicable Wires	AWG24, 26, 28, 30
Cable Finished Diameter	16 dia. max.

· External Dimensions of Case (Units: mm)

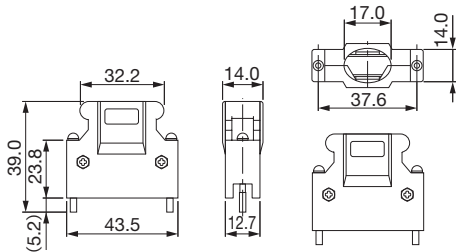

· External Dimensions of Connector (Units: mm)

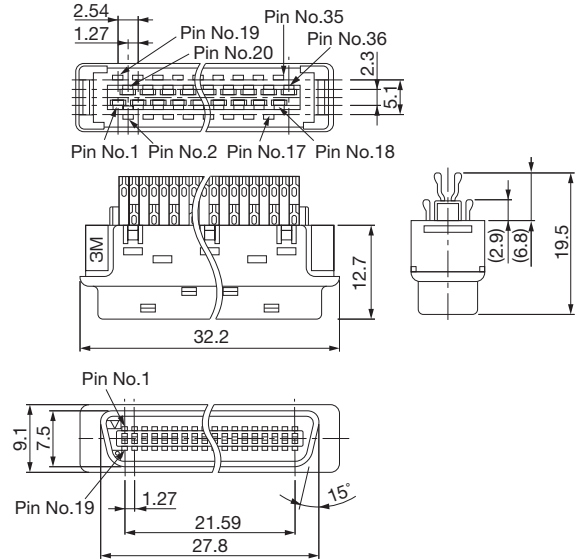

(b) Connector Terminal Converter Unit for CN11

· Dimensions (Units: mm)

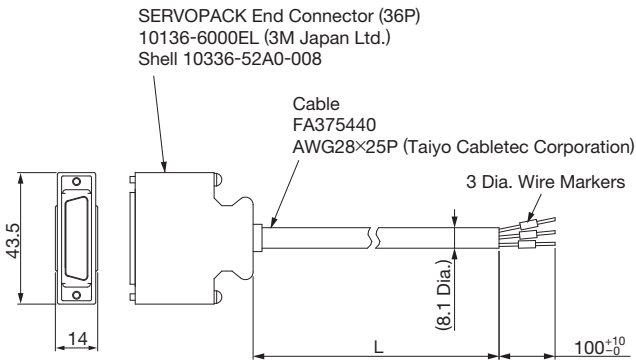

Model	Cable Length (L)
JZSP-CVI01-1-E	1 m
JZSP-CVI01-2-E	2 m
JZSP-CVI01-3-E	3 m

●Cable with Loose Wires at One End for CN11 Connection Diagram of JZSP-CVI01-□-E Cable

Pin No.	SERVOPACK End			Host Controller End	
	Signal	Wire Color	Marking	Lead	Marker
1	COM+	Orange	Red 1	1	1
2	-	-	-	-	-
3	/MODE0/1	Gray	Red 1	3	3
4	-	-	-	-	-
5	STR-STP /HOME	White	Red 1	5	5
6	-	-	-	-	-
7	PGMRES /JOGP	Yellow	Red 1	7	7
8	-	-	-	-	-
9	SEL0 /JOGN	Pink	Red 1	9	9
10	-	-	-	-	-
11	SEL1 /JOG0	Orange	Red 2	11	11
12	-	-	-	-	-
13	SEL2 /JOG1	Gray	Red 2	13	13
14	SEL5	White	Red 2	14	14
15	SEL3 /JOG2	Yellow	Red 2	15	15
16	SEL6	Pink	Red 2	16	16
17	SEL4 /JOG4	Orange	Red 3	17	17
18	SEL7	Gray	Red 3	18	18
19	INPOS+	White	Red 3	19	19
20	INPOS-	White	Black 3	20	20
21	POUT0+	Yellow	Red 3	21	21
22	POUT0-	Yellow	Black 3	22	22
23	POUT1+	Pink	Red 3	23	23
24	POUT1-	Pink	Black 3	24	24
25	POUT2+	Orange	Red 4	25	25
26	POUT2-	Orange	Black 4	26	26
27	POUT3+	Gray	Red 4	27	27
28	POUT3-	Gray	Black 4	28	28
29	POUT4+	White	Red 4	29	29
30	POUT4-	White	Black 4	30	30
31	POUT5+	Yellow	Red 4	31	31
32	POUT5-	Yellow	Black 4	32	32
33	POUT6+	Pink	Red 4	33	33
34	POUT6-	Pink	Black 4	34	34
35	POUT7+	Orange	Red 5 or more	35	35
36	POUT7-	Orange	Black 5 or more	36	36
Case	Shield	-	-	-	-

⚡ Represents twisted-pair wires.

Cable for INDEXER Module (Option)

(c) Cable with Terminal Block at One End (for CN11)

• Configurations

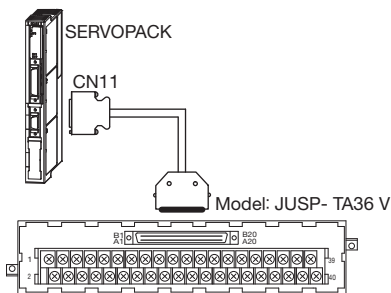

• External Dimensions of Terminal Block (Units: mm)

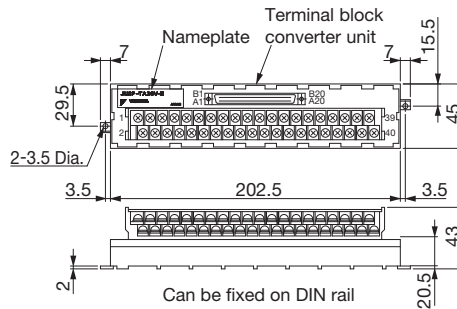

• External Dimensions of Cable (Units: mm)

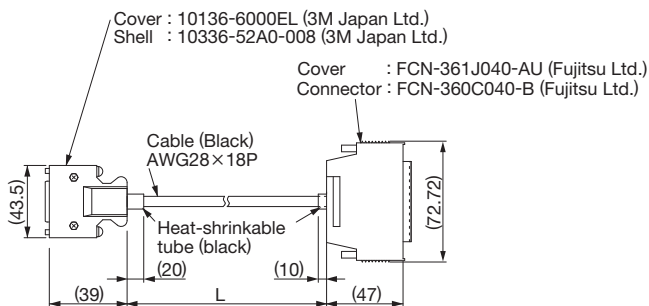

Model	Cable Length (L)	Approx. Mass
JUSP-TA36V-E	0.5 m	100 g
JUSP-TA36V-1-E	1 m	200 g
JUSP-TA36V-2-E	2 m	400 g

Note: The pin number in the SERVOPACK connector and the pin number in the terminal block are the same. Pin numbers 1 to 36 are used in the terminal block. Do not use a pin number of 37 or higher.

If assembling cables, refer to the • Cable with Loose Wires at One End for CN11 Connection Diagram of JZSP-CVI01-□-E Cable on the previous page.

(d) Connector Kit for CN12

Use the following connector and cable to assemble the cable. The CN12 connector kit includes one case and one connector.

Connector Kit Model	Case		Connector	
	Model	Qty	Model	Qty
JZSP-CHI9-1	10314-52A0-008*	1 set	10114-3000PE* (Soldered)	1

* : Manufactured by 3M Japan Ltd.

• Cable Size

Item	Specifications
Cable	Use twisted-pair or twisted-pair shielded wire.
Applicable Wires	AWG24, 26, 28, 30
Cable Finished Diameter	16 dia. max.

• External Dimensions of Case (Units: mm)

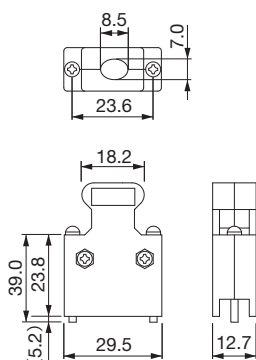

• External Dimensions of Connector (Units: mm)

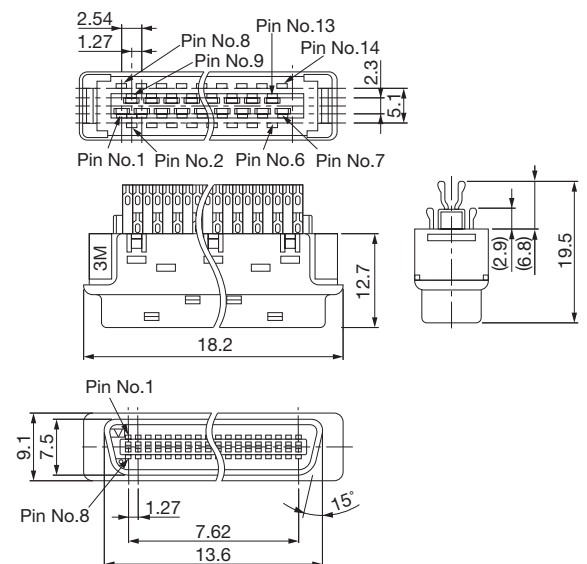

Wiring Main Circuit

Typical Main Circuit Wiring Examples

This section shows examples of the typical wiring for the main circuit.

WARNING

Even after turning OFF the power, high residual voltage may still remain in the SERVOPACK and converter. To prevent electric shock, do not touch the power terminals while charge indicator is still ON. When the voltage is discharged, the charge indicator will turn OFF. Make sure the charge indicator is OFF before starting wiring or inspection.

● Three-phase 200 V

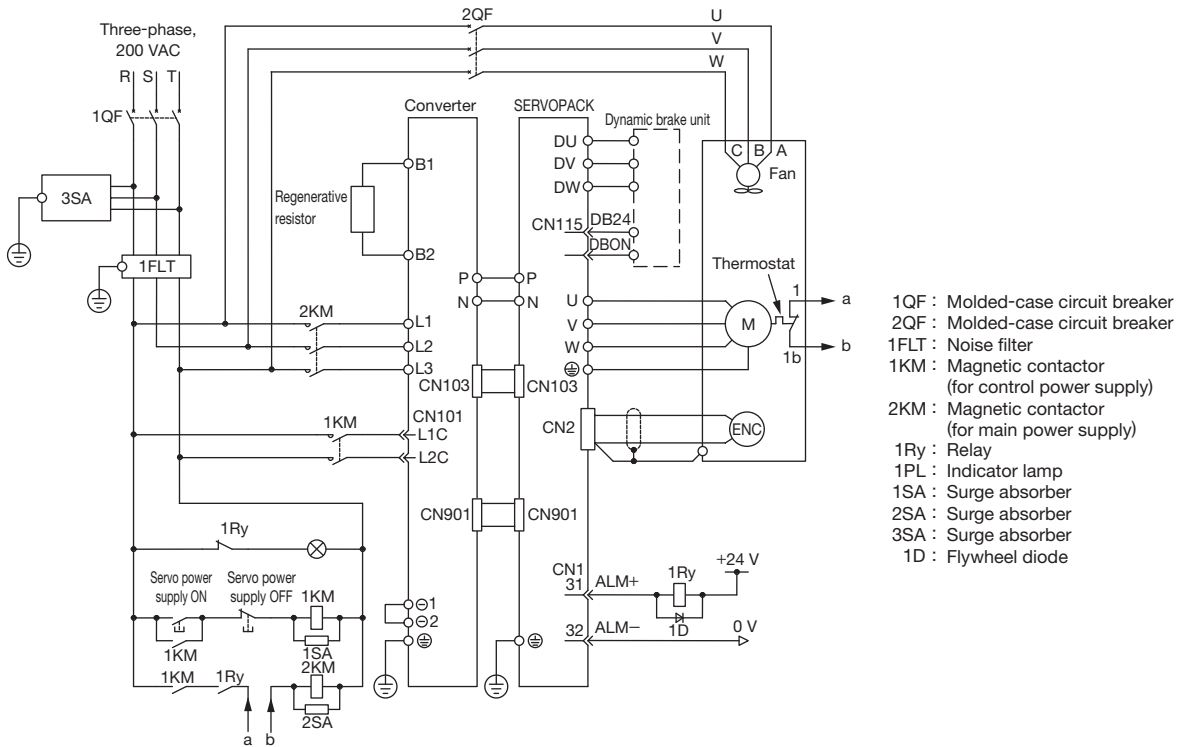

● Three-phase 400 V

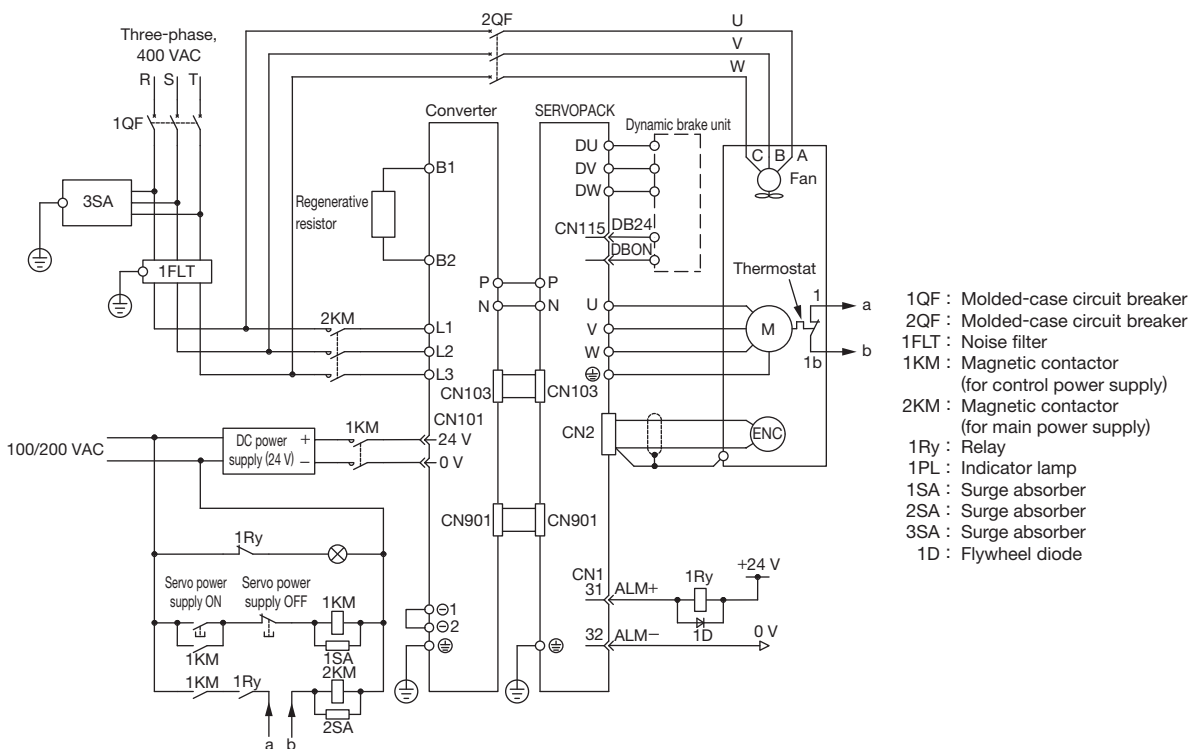

General Precautions for Wiring

IMPORTANT

- Use a molded-case circuit breaker (1QF) or fuse to protect the Main Circuit.
The SERVOPACK and converter connect directly to a commercial power supply; they are not isolated by a transformer or other device. Always use a molded-case circuit breaker (1QF) or fuse to protect the servo system from accidents involving different power system voltages or other accidents.
- Install a ground fault detector.
The SERVOPACK and converter do not have a built-in protective circuit for grounding. To configure a safer system, install a ground fault detector against overloads and short-circuiting, or install a ground fault detector combined with a molded-case circuit breaker.
- Do not turn the power ON and OFF more than necessary.
 - Do not use a SERVOPACK or converter for applications that require the power to turn ON and OFF frequently. Such applications will cause elements in the SERVOPACK or converter to deteriorate.
 - As a guideline, at least one hour should be allowed between the power being turned ON and OFF once actual operation has been started.

To ensure safe, stable application of the servo system, observe the following precautions when wiring.

- Use the specified connection cables. For details, contact your Yaskawa representative and the sales department. Design and arrange the system so that each cable will be as short as possible.
- Use shielded twisted-pair cables or screened unshielded twisted-pair cables for I/O signal cables and encoder cables.
- Use the busbars that are included with the converter and connect the P and N terminals on the SERVOPACK and converter securely.
- The maximum cable length is 3 m for I/O signal cables, 50 m for connection cables for servomotor main circuit, and 50 m for encoder cables, and 10 m for 24-V control power supply cables to 400-V converters.

Observe the following precautions when wiring the ground.

- Ground SERVOPACKs and converters with a 200-V input to 100 Ω or less. Ground SERVOPACKs and converters with a 400-V input to 10 Ω or less.
- Be sure to ground at only one point.
- Ground the servomotor directly if the servomotor is insulated from the machine.

The signal cable conductors are as thin as 0.2 mm² or 0.3 mm². Do not impose excessive bending force or tension.

SERVOPACK Main Circuit Wire

● Three-phase, 200 V

Combination of SERVOPACK and Converter		Terminal Symbols	Screw Size for Terminals	HIV Wire Size in mm ² (AWG)	Crimp Terminal Model (Made by J.S.T. Mfg Co., Ltd.)*
SGDV-121H	SERVOPACK	P, N	M8	Bus bar attached to the converter	—
		U, V, W	M8	60 (2/0)	R60-8
		DU, DV, DW	M6	5.5 (10)	R5.5-6
		⊕	M8	60 (2/0)	R60-8
SGDV-COA2BAA	Converter	P, N	M8	Bus bar attached to the converter	—
		L1, L2, L3	M8	38 (1)	R38-8
		⊖1, ⊖2	M8	38 (1)	R38-8
		CN101 (200 VAC)	— (Connector)	1.25 (16)	—
		B1, B2	M8	8 (8)	R8-8
		⊕	M8	38 (1)	R38-8
SGDV-161H	SERVOPACK	P, N	M8	Bus bar attached to the converter	—
		U, V, W	M8	100 (4/0)	CB100-S8
		DU, DV, DW	M6	5.5 (10)	R5.5-6
		⊕	M8	100 (4/0)	100-8
SGDV-COA3GAA	Converter	P, N	M10	Bus bar attached to the converter	—
		L1, L2, L3	M10	60 (2/0)	R60-10
		⊖1, ⊖2	M10	60 (2/0)	R60-10
		CN101 (200 VAC)	— (Connector)	1.25 (16)	—
		B1, B2	M10	14 (6)	R14-10
		⊕	M8	60 (2/0)	R60-8
SGDV-201H	SERVOPACK	P, N	M10	Bus bar attached to the converter	—
		U, V, W	M10	100 (4/0)	R100-10
		DU, DV, DW	M6	5.5 (10)	R5.5-6
		⊕	M8	100 (4/0)	100-8
SGDV-COA3GAA	Converter	P, N	M10	Bus bar attached to the converter	—
		L1, L2, L3	M10	100 (4/0)	R100-10
		⊖1, ⊖2	M10	100 (4/0)	R100-10
		CN101 (200 VAC)	— (Connector)	1.25 (16)	—
		B1, B2	M10	14 (6)	R14-10
		⊕	M8	100 (4/0)	100-8

* : Use the crimp terminals that are recommended by Yaskawa or an equivalent. The tools required for using crimp terminals are shown on the next page.

● Three-phase, 400 V

Combination of SERVOPACK and Converter		Terminal Symbols	Screw Size for Terminals	HIV Wire Size in mm ² (AWG)	Crimp Terminal Model (Made by J.S.T. Mfg Co., Ltd.)*
SGDV-750J	SERVOPACK	P, N	M8	Bus bar attached to the converter	—
		U, V, W	M8	22 (4)	R22-8
		DU, DV, DW	M6	3.5 (12)	3.5-6
		⊕	M8	22 (4)	R22-8
SGDV-COA3ZDA	Converter	P, N	M8	Bus bar attached to the converter	—
		L1, L2, L3	M8	22 (4)	R22-8
		⊖1, ⊖2	M8	22 (4)	R22-8
		CN101 (24 V, 0 V)	— (Connector)	1.25 (16)	—
		B1, B2	M8	8 (8)	R8-8
		⊕	M8	22 (4)	R22-8
SGDV-101J	SERVOPACK	P, N	M8	Bus bar attached to the converter	—
		U, V, W	M8	38 (1)	R38-8
		DU, DV, DW	M6	3.5 (12)	3.5-6
		⊕	M8	38 (1)	R38-8
SGDV-COA5EDA	Converter	P, N	M10	Bus bar attached to the converter	—
		L1, L2, L3	M10	38 (1)	R38-10
		⊖1, ⊖2	M10	38 (1)	R38-10
		CN101 (24 V, 0 V)	— (Connector)	1.25 (16)	—
		B1, B2	M10	8 (8)	R8-10
		⊕	M8	38 (1)	R38-8
SGDV-131J	SERVOPACK	P, N	M10	Bus bar attached to the converter	—
		U, V, W	M10	60 (2/0)	R60-10
		DU, DV, DW	M6	3.5 (12)	3.5-6
		⊕	M8	60 (2/0)	R60-8
SGDV-COA5EDA	Converter	P, N	M10	Bus bar attached to the converter	—
		L1, L2, L3	M10	60 (2/0)	R60-10
		⊖1, ⊖2	M10	60 (2/0)	R60-10
		CN101 (24 V, 0 V)	— (Connector)	1.25 (16)	—
		B1, B2	M10	14 (6)	R14-10
		⊕	M8	60 (2/0)	R60-8

* : Use the crimp terminals that are recommended by Yaskawa or an equivalent. The tools required for using crimp terminals are shown on the next page.

SERVOPACK Main Circuit Wire

● Tools for Crimp Terminals

Model	Tools by J.S.T. Mfg Co., Ltd.		
	Body	Head	Dies
3.5-6 R5.5-6	YHT-2210	–	–
R8-8	YHT-8S	–	–
R8-10	YPT-150-1	–	TD-221, TD-211
R14-10	YPT-150-1	–	TD-222, TD-211
R22-8			TD-223, TD-212
R38-8			TD-224, TD-212
R38-10			TD-225, TD-213
R60-8			TD-225, TD-213
R60-10	YF-1	YET-150-1	TD-225, TD-213
100-8	YF-1	YET-150-1	TD-228, TD-214
R100-10			
CB100-S8			

● Wire Type

Wire Type		Allowable Conductor Temperature °C
Code	Name	
IV	600 V polyvinyl chloride insulated wire	60
HIV	600 V grade heat-resistant polyvinyl chloride insulated wire	75

The following table shows the wire sizes and allowable currents for three wires. Use wires with specifications equal to or less than those shown in the table.

● 600 V grade heat-resistant polyvinyl chloride insulated wire (HIV)

Nominal Cross Section Area mm ²	AWG Size	Configuration Number of Wires/mm	Conductive Resistance Ω/km	Allowable Current at Surrounding Air Temperature A		
				30°C	40°C	50°C
0.5	(20)	19/0.18	39.5	6.6	5.6	4.5
0.75	(19)	30/0.18	26	8.8	7	5.5
0.9	(18)	37/0.18	24.4	9	7.7	6
1.25	(16)	50/0.18	15.6	12	11	8.5
2	(14)	7/0.6	9.53	23	20	16
3.5	(12)	7/0.8	5.41	33	29	24
5.5	(10)	7/1.0	3.47	43	38	31
8	(8)	7/1.2	2.41	55	49	40
14	(6)	7/1.6	1.35	79	70	57
22	(4)	7/2.0	0.85	91	81	66
38	(1)	7/2.6	0.49	124	110	93
60	(2/0)	19/2.0	0.3	170	150	127
100	(4/0)	19/2.6	0.18	240	212	179

Note: The values in the table are for reference only.

IMPORTANT

- 1 The specified wire sizes are for use when the three lead cables are bundled and when the rated electric current is applied with a surrounding air temperature of 40°C.
- 2 Use a wire with a minimum withstand voltage of 600 V for the main circuit.
- 3 If cables are bundled in PVC or metal ducts, take into account the reduction of the allowable current.
- 4 Use a heat-resistant wire under high surrounding air or panel temperatures, where polyvinyl chloride insulated wires will rapidly deteriorate.

Peripheral Devices

Molded-case Circuit Breaker and Fuse Capacity

● Recommendations

Main Circuit Power Supply	Applicable Servomotor Max. Capacity kW	Combination of SERVOPACK and Converter		Power Supply Capacity for Each SERVOPACK-Converter Set kVA	Current Capacity		Inrush Current		Rated Voltage	
		SERVOPACK Model SGD V-	Converter Model SGD V-COA		Main Circuit Arms	Control Circuit Arms	Main Circuit A0-p	Control Circuit A0-p	Fuse V	Circuit Breaker V
Three-phase 200 V	22	121H	2BAA	38	127	1.2* ¹	163	16	250	240
	30	161H	3GAA	52	174	1.2* ¹	163	16		
	37	201H	3GAA	64	214	1.2* ¹	163	16		
Three-phase 400 V	30	750J	3ZDA	52	87	4* ²	170	—	600	480
	37	101J	5EDA	64	107	4* ²	170	—		
	55	131J	5EDA	95	159	4* ²	170	—		

*1 : Input voltage of 200 VAC

*2 : Input voltage of 24 VDC

Notes: 1 The values in the above table are for a combination of one SERVOPACK and one converter. If using more than one SERVOPACK or more than one converter, find the total value for the combination to be used.

2 The rated input current is the net value for the rated load. When selecting the molded-case circuit breaker and fuse capacity, find the capacity by derating as specified below. Breaking characteristic (25°C): 5 s min. at 300%

3 To comply with the low voltage directive, connect a fuse to the input side. Select the fuse or molded-case circuit breaker for the input side from among models that are compliant with UL standards.

The table above also provides the net values of current capacity and inrush current. Select a fuse and a molded-case circuit breaker which meet the breaking characteristics shown below.

- Main circuit, control circuit: No breaking at three-times the current values of the table for 5 s.

- Inrush current: No breaking at the same current values of the table for 20 ms.

4 In accordance with UL standards, the following restrictions apply.

Noise Filters

● Noise Filter Selection

Main Circuit Power Supply	Combination of SERVOPACK and Converter		Recommended Noise Filter		
	SERVOPACK Model SGD V-	Converter Model SGD V-COA	Model	Specifications	Leakage Current
Three-phase 200 V	121H	2BAA	HF3150C-UQB	Three-phase, 480 VAC, 150 A	10 mA 400 VAC/50 Hz
	161H	3GAA	HF3200C-UQB	Three-phase, 480 VAC, 200 A	
	201H	3GAA	HF3250C-UQB	Three-phase, 480 VAC, 250 A	
Three-phase 400 V	750J	3ZDA	HF3150C-UQB	Three-phase, 480 VAC, 150 A	10 mA 400 VAC/50 Hz
	101J	5EDA	HF3150C-UQB	Three-phase, 480 VAC, 150 A	
	131J	5EDA	HF3200C-UQB	Three-phase, 480 VAC, 200 A	

IMPORTANT Some noise filters have large amounts of leakage current. The grounding measures taken also affect the extent of the leakage current. If necessary, select an appropriate leakage current detector or leakage current breaker taking into account the grounding measures that are used and leakage current from the noise filter. Contact the manufacturer of the noise filter for details.

● External Dimensions (Units: mm) HF Noise Filters (Soshin Electric Co.)

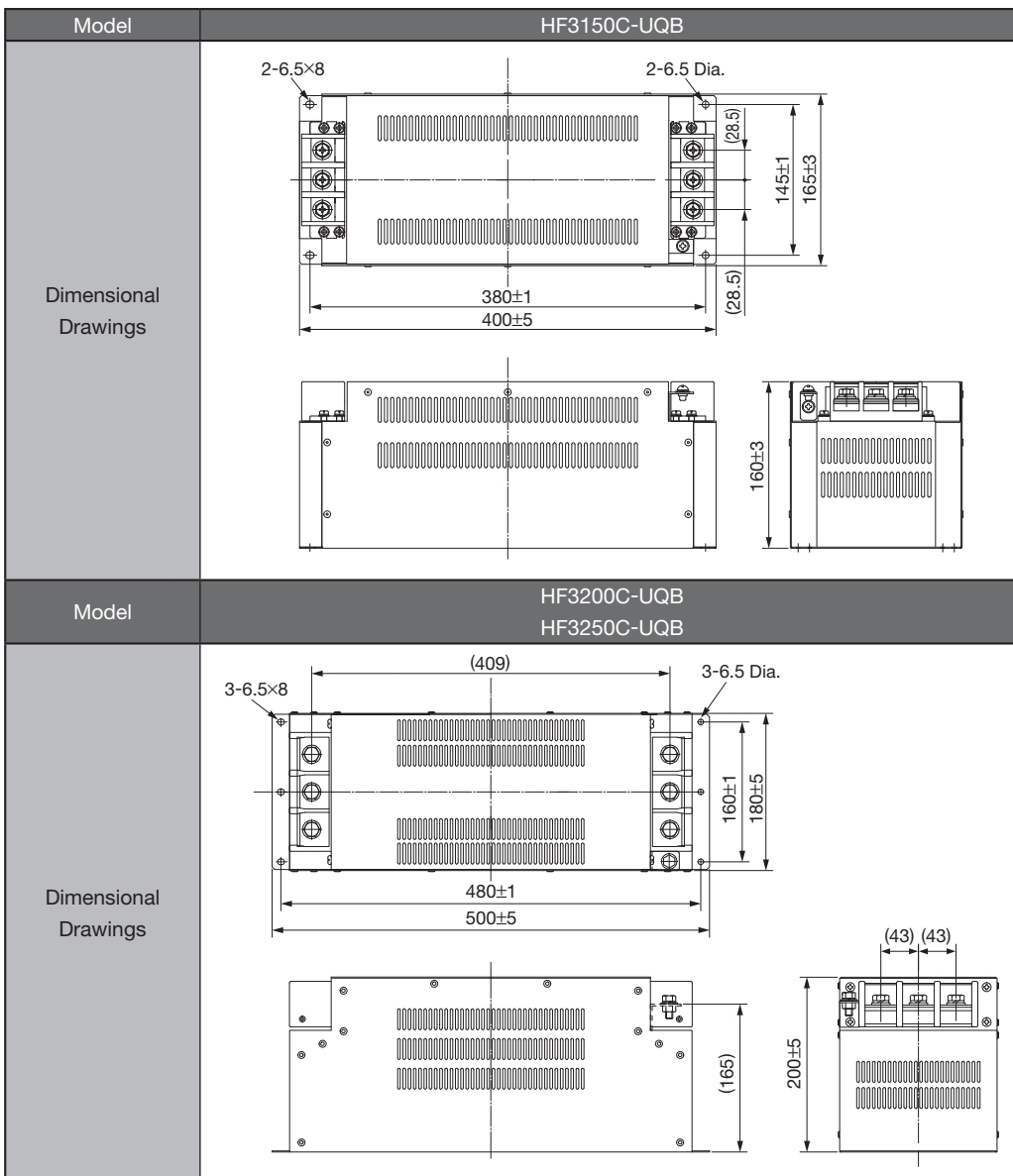

Surge Absorber

●Surge Absorber Selection

The surge absorber (for lightning surge) absorbs lightning surge and prevents faulty operation in or damage to electronic circuits.

Main Circuit Power Supply	SERVOPACK Model	Recommended Surge Absorber
Three-phase 200 V	SGDV-□□□H	LT-C32G801WS
Three-phase 400 V	SGDV-□□□J	LT-C35G102WS

●External Dimensions (Units: mm)

Model: LT-C32G801WS, LT-C35G102WS [by SOSHIN ELECTRIC CO., LTD.]

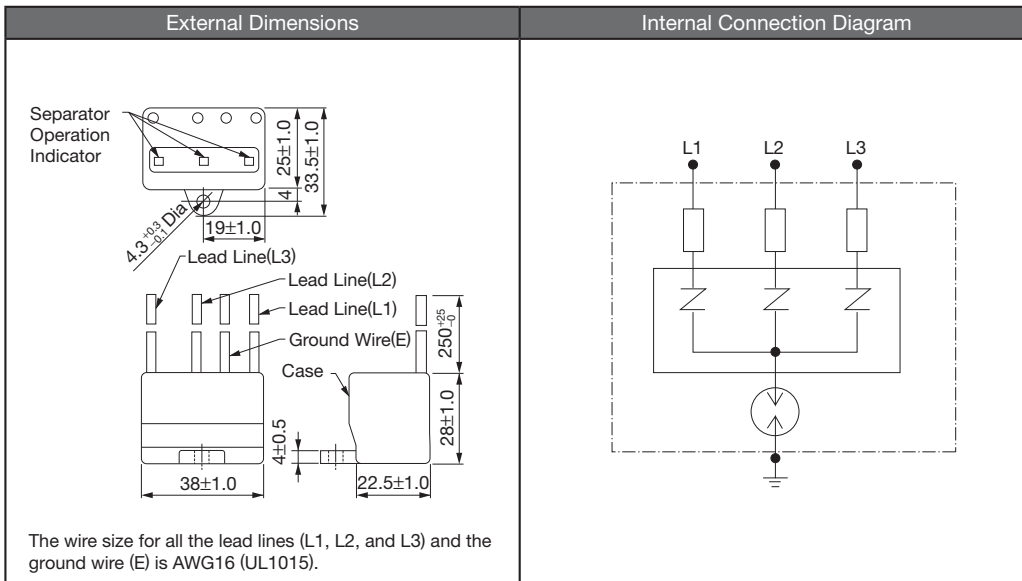

Holding Brake Power Supply Unit

● Holding Brake Power Supply Unit

IMPORTANT

- We recommend opening or closing the circuit for the holding brake's power supply so that switching will occur on the AC side of the holding brake power supply unit. This will reduce brake operation time compared to switching on the DC side.
- When switching on the DC side, install an extra surge absorber (varistor) on the brake side apart from the surge absorber built in the brake circuit to prevent damage to the brake coil from surge voltage.
- Holding brake power supply units for 24 VDC are not provided by Yaskawa. Please obtain these from other manufacturers. Do not connect holding brake power supply units for different output voltages to SERVOPACKs. Overcurrent may result in burning.

● Model

200 V input: LPSE-2H01-E
 100 V input: LPDE-1H01-E

● Specifications

Rated output voltage: 90 VDC
 Maximum output current: DC 1.0 A
 Lead wire length: 500 mm each
 Maximum ambient temperature: 60°C
 Lead wires: Color coded (refer to the table below)

AC input		Brake end
100 V	200 V	
Blue/white	Yellow/white	Red/black

● External Dimensions (Units: mm)

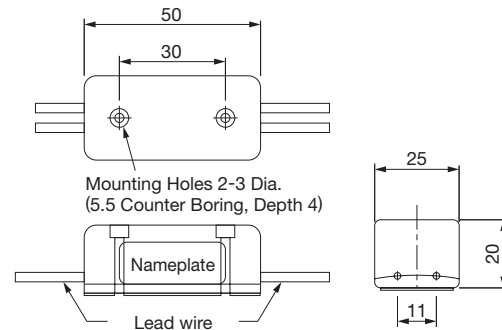

● Internal Circuits

We recommend opening or closing the circuit for the holding brake's power supply so that switching will occur on the AC side of the holding brake power supply unit. This will reduce brake operation time compared to switching on the DC side. When switching on the DC side, install an extra surge absorber (varistor) on the brake side apart from the surge absorber built in the brake circuit to prevent damage to the brake coil from surge voltage. For more information on surge absorbers (varistors) and circuit designs, refer to *Surge Absorbers (Varistors)* on page 78.

<Surge Absorber Selection>

When using the LPSE-2H01-E, select a Z10D471 surge absorber made by SEMITEC Corp.
 When using the LPDE-1H01-E, select a Z10D271 surge absorber made by SEMITEC Corp.

Brake Power Supply for 200 VAC
 Internal Circuit for Model: LPSE-2H01-E

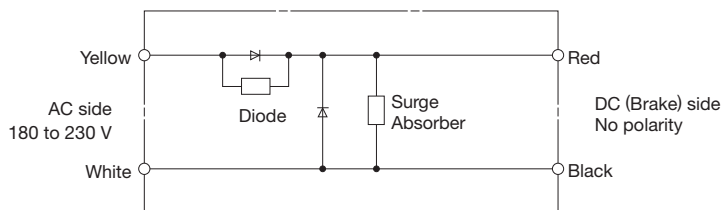

Brake Power Supply for 100 VAC
 Internal Circuit for Model: LPDE-1H01-E

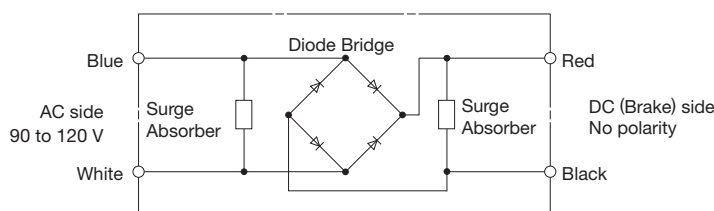

Surge Absorbers for Holding Brakes, Diodes, and Open/Close Relays

●Surge absorbers (Varistors)

Select an appropriate surge absorber for the power voltage and the current of the brake to be used. Refer to the following diagrams for the circuit designs of surge absorbers. Surge absorbers are not included.

Brake Power Supply Voltage	24 VDC			90 VDC			
Surge Absorber Manufacturer	Nippon Chemi-Con	SEMITEC	Nippon Chemi-Con	SEMITEC	Nippon Chemi-Con	SEMITEC	
Brake Rated Current	1 A max.	TNR5V121K	Z5D121	TNR7V271K	Z7D271	TNR7V471K	Z7D471
	2 A max.	TNR7V121K	Z7D121	TNR10V271K	Z10D271	TNR10V471K	Z10D471
	4 A max.	TNR10V121K	Z10D121	—	—	—	—
	8 A max.	TNR14V121K	Z15D121	—	—	—	—
Brake Power Supply	A 24-VDC power supply (not included.)			A 90-VDC power supply (not included) or a LPDE-1H01-E (full-wave rectification)		LPSE-2H01-E (half-wave rectification)	

Note: Surge absorbers do not have any polarity.

The ambient temperature range for surge absorbers is -20°C to 60°C . The element is selected with the condition that it is switched ON and OFF 10 times or less per minute.

The information in the table is just a reference and combinations of these products with brakes do not guarantee the braking characteristics. When selecting surge absorbers for your application, consider the product life and test all operations, including brake timing before use.

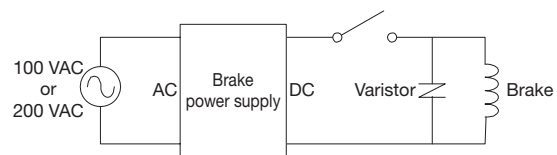
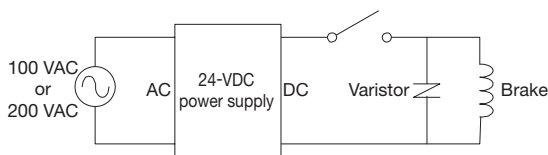

●Diodes

Diodes can be used to suppress back surge that occurs when a relay contact opens. Note that when diodes are used, more time is required to brake than when surge absorbers are used. Select diodes with a rated current greater than that of the brakes and with the recommended withstand voltage shown in the following table. Diodes are not included.

Brake Power Supply Voltage	Withstand Voltage
24 VDC	100 to 200 V
90 VDC (Full-wave rectification)	400 to 600 V
90 VDC (Half-wave rectification)	800 V min.

Note: Diodes have polarities. Refer to the following diagram when connecting diodes.

When selecting diodes for your application, consider the product life and conduct tests such as operation tests before use.

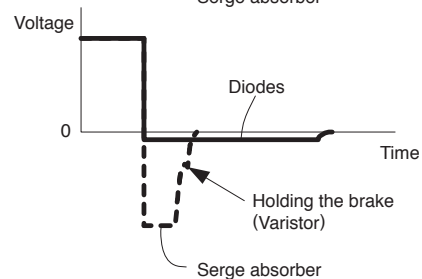
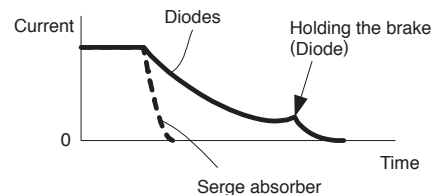
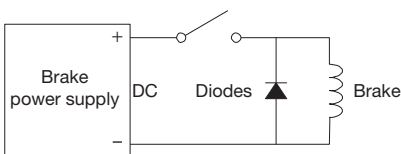

●Open/close relays for brakes

Select an open/close relay that can be used at the voltage and current of the brake used. When using a SSR (solid state relay) which is a semiconductor relay, use diodes to absorb any back surge. Open/close relays are not included.

Regenerative Resistor

● Regenerative Power and Regenerative Resistance

The rotational energy of driven machine such as servomotor is returned to the SERVOPACK. This is called regenerative power. The regenerative power is absorbed by charging the smoothing capacitor, but when the chargeable energy is exceeded, the regenerative power is further consumed by the regenerative resistor.

The servomotor is driven in regeneration state in the following circumstances:

- While decelerating to a stop during acceleration and deceleration operation.
- Continuous operation on the vertical axis.
- During continuous operation with the servomotor rotated from the load side (negative load).

Continuous operation in which the force of the load causes the servomotor to rotate is call negative load operation. Do not perform negative load operation. The following figures show typical examples of negative load operation.

● Lowering Objects with the Motor without a Counterweight

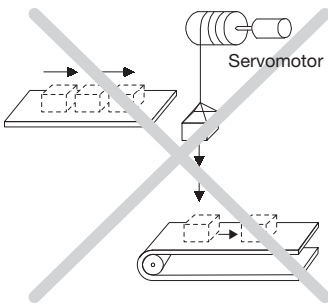

● Feeding Material with the Motor

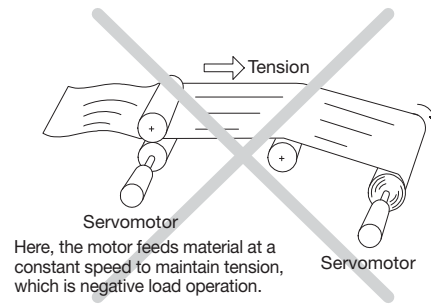

IMPORTANT

- Do not perform negative load operation. During negative load operation, regenerative braking is applied continuously by the SERVOPACK. The regenerative energy of the load may exceed the allowable range and damage the SERVOPACK.
- The regenerative brake capacity of the SGD V SERVOPACKs is rated for short-term operation approximately equivalent to the time it takes to decelerate to a stop.

You must connect a regenerative resistor. Use the SigmaSize+ AC for servo drive capacity selection program to calculate the capacity. If you use a Yaskawa regenerative resistor, refer to (1) Using a Regenerative Resistor from Yaskawa. If you use a regenerative resistor from another company, refer to (2) Using a Regenerative Resistor from Another Company.

● Recommendations

(1) Using a Regenerative Resistor from Yaskawa

The SERVOPACKs and the converters do not have built-in regenerative resistors. If you use a regenerative resistor from Yaskawa, select it according to the combinations specified by Yaskawa in the following table. You must obtain the regenerative resistor separately.

Main Circuit Power Supply Voltage	SERVOPACK Model SGDV-	Converter Model SGDV-COA	Model of Applicable regenerative resistor	Resistance Ω	Capacity W	Specifications
Three-phase 200 V	121 H	2BAA	JUSP-RA08-E	2.4	2400	Four 0.6- Ω (600-W) resistors connected in series
	161 H	3GAA	JUSP-RA09-E	1.8	4800	Two sets of four 0.9- Ω (600-W) resistors connected in series are connected in parallel.
	201H	3GAA	JUSP-RA11-E	1.6	4800	Eight 0.2- Ω (600-W) resistors connected in series
Three-phase 400 V	750J	3ZDA	JUSP-RA13-E	6.7	3600	Three sets of two 10- Ω (600-W) resistors connected in series are connected in parallel.
	101J	5EDA	JUSP-RA14-E	5	4800	Four sets of two 10- Ω (600-W) resistors connected in series are connected in parallel.
	131J	5EDA	JUSP-RA16-E	3.8	7200	Four sets of three 5- Ω (600-W) resistors connected in series are connected in parallel.

Notes: 1 If you use any combination of regenerative resistor, SERVOPACK, and converter that is not specified by Yaskawa, always set the resistive capacity in the Pn600 parameter (Regenerative Resistor Capacity) in the SERVOPACK. If you use a combination that is specified by Yaskawa, leave the setting of the Pn600 parameter in the SERVOPACK at the default setting.

2 For detailed specification on regenerative resistors, contact your Yaskawa representative or a Yaskawa sales department.

3 If there will be continuous operation in regenerative mode, such as for a vertical axis, calculate the required capacity (W) of the regenerative resistor. Refer to *Regenerative Resistor Capacity Selection*.

(2) Using a Regenerative Resistor from Another Company

If you use a regenerative resistor from another company, contact your Yaskawa representative or a Yaskawa sales department.

Main Circuit Power Supply Voltage	SERVOPACK Model SGDV-	Converter Model SGDV-COA	Minimum Allowable Resistance Ω
Three-phase 200 V	121H	2BAA	1.33
	161H	3GAA	1.0
	201H	3GAA	1.0
Three-phase 400 V	750J	3ZDA	2.0
	101J	5EDA	2.0
	131J	5EDA	2.0

Notes: 1 If you use a regenerative resistor from another company, we recommend a regenerative resistor with a thermal switch for safety.

2 If you use a regenerative resistor from another company, always set the resistive capacity in the Pn600 parameter (Regenerative Resistor Capacity) in the SERVOPACK. For details, refer to 3.7.3 *Setting the Regenerative Resistor Capacity* in the User's Manual, Design and Maintenance (manual No.: SIEP S800000 88).

Regenerative Resistor

External Dimensions (Units: mm)

(1) JUSP-RA08-E

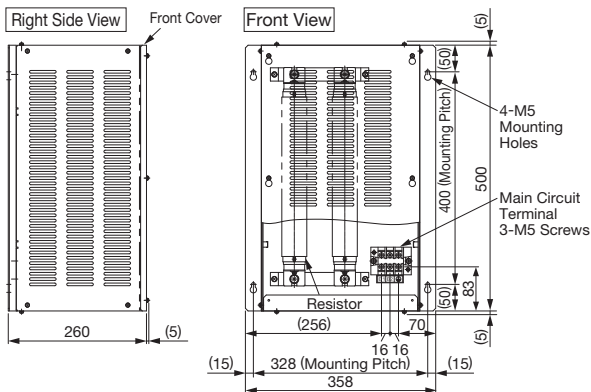

Approx. Mass: 14.0 kg

(2) JUSP-RA09-E

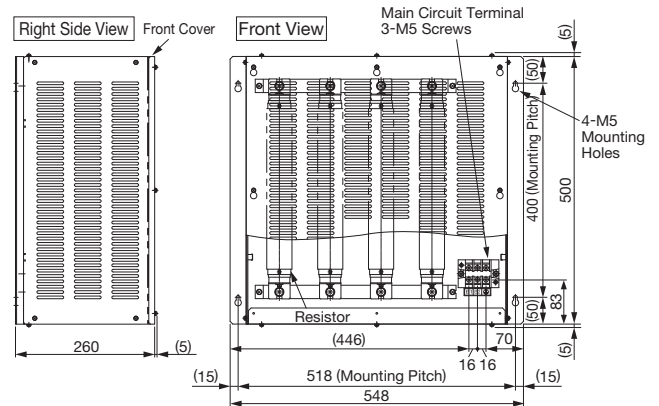

Approx. Mass: 21.0 kg

(3) JUSP-RA11-E

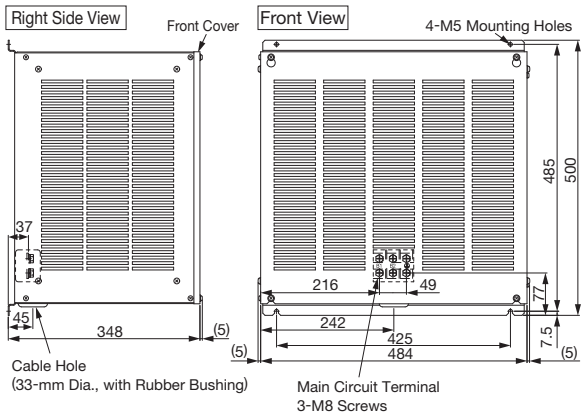

Approx. Mass: 20.5 kg

(4) JUSP-RA13-E

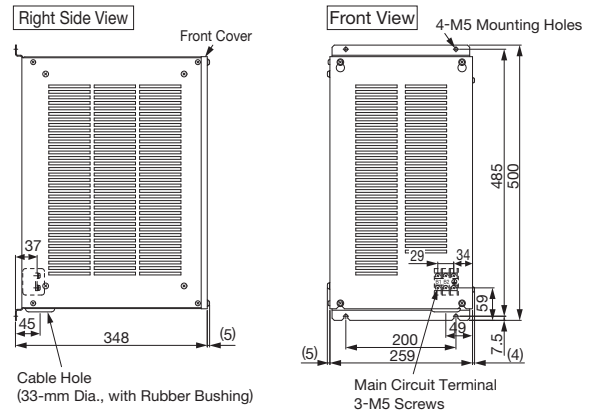

Approx. Mass: 14.0 kg

(5) JUSP-RA14-E

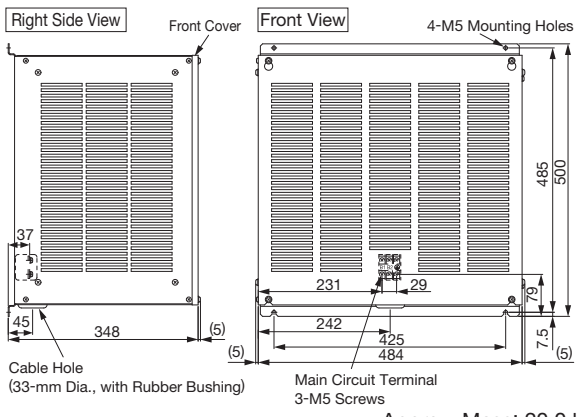

Approx. Mass: 20.0 kg

(6) JUSP-RA16-E

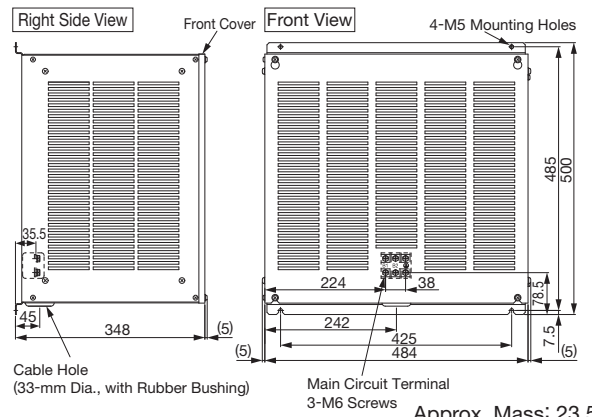

Approx. Mass: 23.5 kg

Installation Standards

Observe the following installation standards when you use a Yaskawa regenerative resistor. Provide at least 70 mm on each side of the unit and at least 200 mm at both the top and bottom of the unit to enable fan and natural convection cooling.

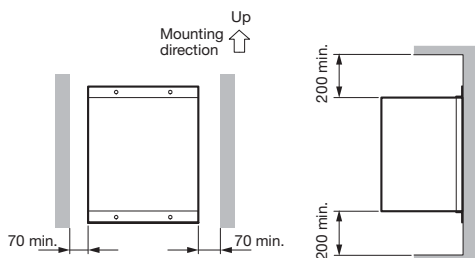

Note: If you use a regenerative resistor from another company, install it according to the manufacturer's specifications.

Dynamic Brake Unit

● Dynamic Brake Unit Selection

To use the dynamic brake (DB), externally connect a dynamic brake unit or dynamic brake resistor to the SERVOPACK to process the dynamic braking energy. If you use a dynamic brake resistor from Yaskawa, use the following table to select it. You must obtain the dynamic brake unit separately.

Note: Refer to *Selecting Cables* for a cable to connect the dynamic brake unit or dynamic brake contactor to CN115 on the SERVOPACK.

(1) Using a Dynamic Brake Unit from Yaskawa

Main Circuit Power Supply Voltage	SERVOPACK Model SGD V-	Dynamic Brake Unit Model	Resistance Specifications (Star Wiring Δ)	Dynamic Brake Contactor and Surge Absorption Unit
Three-phase 200 V	121H, 161H, 201H	JUSP-DB02-E	180 W, 0.3 Ω \times 3 (Star Wiring Δ)	Built into dynamic brake unit.
Three-phase 400 V	750J, 101J	JUSP-DB04-E	180 W, 0.8 Ω \times 3 (Star Wiring Δ)	Built into dynamic brake unit.
	131J	JUSP-DB06-E	300 W, 0.8 Ω \times 3 (Star Wiring Δ)	Built into dynamic brake unit.

(2) Using a Dynamic Brake Unit from Another Company

To order a dynamic brake unit, contact the manufacturer directly.

Main Circuit Power Supply Voltage	Model	Manufacturer	Required Resistance
Three-phase 200 V	GR series	Japan Resistor Mfg. Co., Ltd.	0.3 Ω or greater
Three-phase 400 V			0.8 Ω or greater

Use the following dynamic brake contactors and surge absorption units.

Main Circuit Power Supply Voltage	SERVOPACK Model	Name	Model	Manufacturer	
Three-phase 200 V	SGDV-□□□H	Contactor		SC-4-1/G Coil: 24 VDC	Fuji Electric Co., Ltd.
		Main circuit surge absorption unit*	Head-on type	SZ-ZM1	
			Side-on type	SZ-ZM2	
		Coil surge absorption unit		SZ-Z4	
Three-phase 400 V	SGDV-□□□J	Contactor		SC-4-1/G Coil: 24 VDC	Fuji Electric Co., Ltd.
		Main circuit surge absorption unit*	Head-on type	SZ-ZM1	
			Side-on type	SZ-ZM2	
		Coil surge absorption unit		SZ-Z4	

* : Use either a head-on or side-on main circuit surge absorption unit.

Notes: 1 The dynamic brake answer function on a Yaskawa dynamic brake unit cannot be used because there are no auxiliary contacts on the contactor. The dynamic brake answer function would allow you to use auxiliary contacts on the contactor in the dynamic brake circuit with the dynamic brake answer signal (/DBANS) to detect welding or failure to operation. To use the dynamic brake answer function, select a contactor that has auxiliary contacts. For details, refer to the User's Manual, Design and Maintenance for your SERVOPACK.

2 The settings of the SERVOPACK parameters depend on the following conditions. For details, refer to the User's Manual, Design and Maintenance for your SERVOPACK.

- Whether you connect a dynamic brake unit.
- Whether the dynamic brake unit is from Yaskawa or from another company

Dynamic Brake Unit

External Dimensions (Units: mm)

(1) JUSP-DB02-E

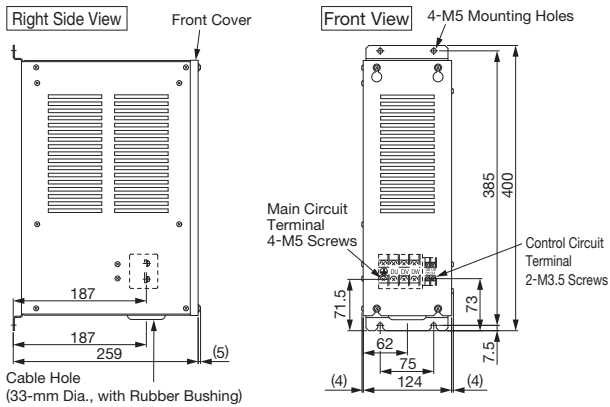

Approx. Mass: 6.0 kg

(2) JUSP-DB04-E

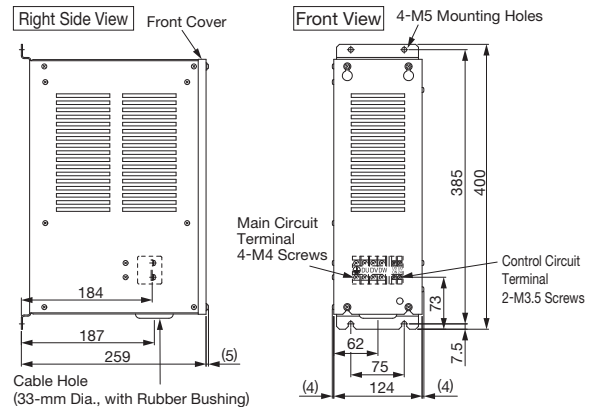

Approx. Mass: 6.0 kg

(3) JUSP-DB06-E

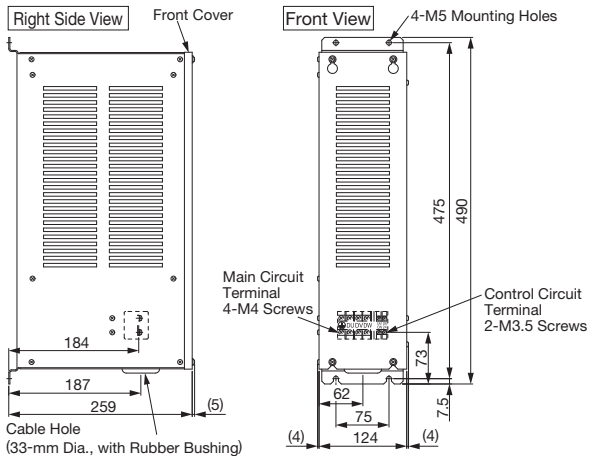

Approx. Mass: 7.0 kg

Installation Standards

Observe the following installation standards when you use a Yaskawa dynamic brake unit. Provide at least 70 mm on each side of the unit and at least 200 mm at both the top and bottom of the unit to enable fan and natural convection cooling.

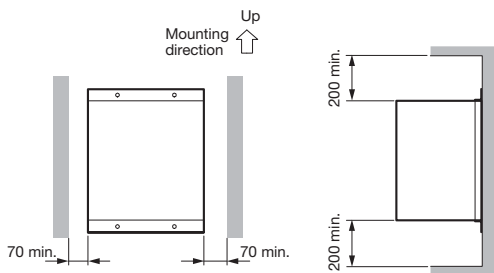

Note: If you use a dynamic brake unit from another company, install it according to the manufacturer's specifications.

Dynamic Brake Unit

● Connections

(1) Using a Dynamic Brake Unit from Yaskawa

A dynamic brake contactor is built into a Yaskawa dynamic brake unit. The connections are shown in the following figure.

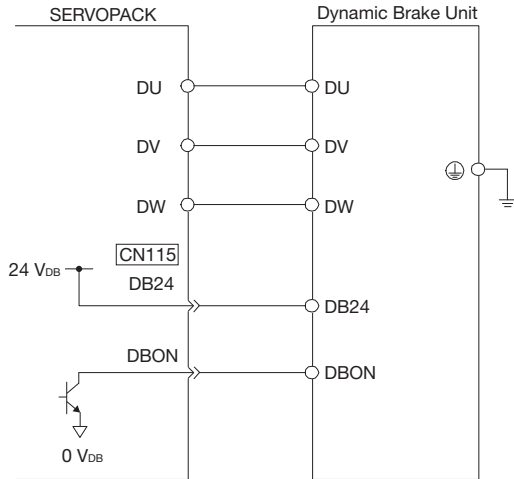

Note: The dynamic brake answer function cannot be used because there are no auxiliary contacts on the contactor.

(2) Using a Dynamic Brake Unit from Another Company

· Using NO Contacts for the Dynamic Brake Contactor

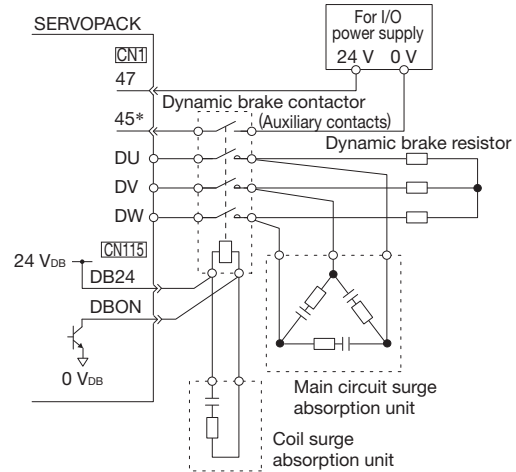

* : The above figure is for using a dynamic brake contactor with NO contacts. The dynamic brake answer signal (a signal from NO auxiliary contacts) is input to CN1-45. To indicate an error if the input signal to CN1-45 turns OFF (open) while the dynamic brake is activated, the Pn515 parameter in the SERVOPACK must be set to n.□E□□. If the dynamic brake answer signal is not used, Pn515 is set to n.□8□□ (default setting).

Notes: 1 If you assign more than one signal to the same input circuit, OR logic will be used and any of the input signals will cause the circuit to operate. This may result in unexpected operation.
2 The maximum current for DB24 and DBON is 300 mA.

(3) Using a Dynamic Brake Unit from Another Company

· Using NC Contacts for the Dynamic Brake Contactor

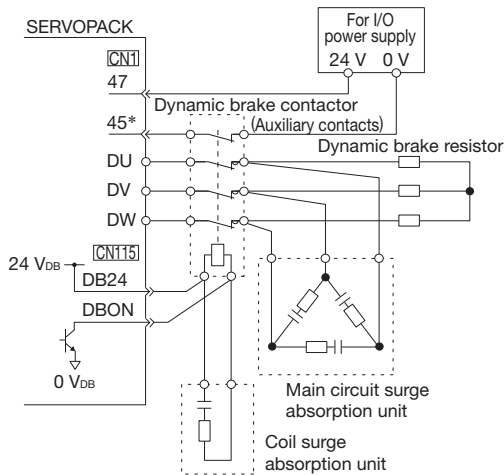

* : The above figure is for using a dynamic brake contactor with NC contacts. The dynamic brake answer signal (a signal from NC auxiliary contacts) is input to CN1-45. To indicate an error if the input signal to CN1-45 turns OFF (open) while the dynamic brake is activated, the Pn515 parameter in the SERVOPACK must be set to n.□E□□. If the dynamic brake answer signal is not used, Pn515 is set to n.□8□□ (default setting).

Notes: 1 If you assign more than one signal to the same input circuit, OR logic will be used and any of the input signals will cause the circuit to operate. This may result in unexpected operation.
2 The maximum current for DB24 and DBON is 300 mA.

(4) Using a Dynamic Brake Unit from Another Company

· If the coil current of NC dynamic brake contactors is 300 mA or higher, obtain an NO relay that can switch the contactor coil current and voltage and a power supply for the contactor coil.

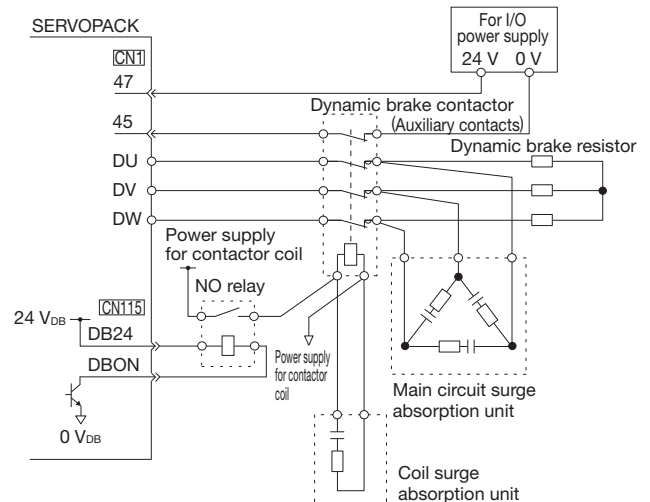

Capacity Selection

Servomotor Capacity Selection Examples

Use the AC servo drive capacity selection program SigmaSize+ to select servomotor capacity. The program can be downloaded for free from our web site (<http://www.e-mechatronics.com/>).

● Selection Example for Speed Control

Mechanical Specifications

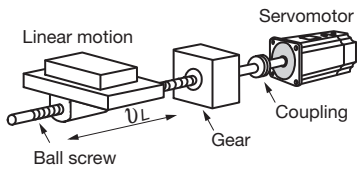

- Load speed: $v_L = 12$ m/min
- Linear motion section mass: $m = 750$ kg
- Ball screw length: $\ell_B = 2.0$ m
- Ball screw diameter: $d_B = 0.1$ m
- Ball screw lead: $P_B = 0.012$ m
- Ball screw material density: $\rho = 7.87 \times 10^3$ kg/m³
- Gear ratio: 1/2 (R = 2)
- Gear + coupling moment of inertia : $J_G = 12 \times 10^{-4}$ kg·m²
- Feeding times: $n = 10$ times/min
- Feeding distance: $\ell = 0.21$ m
- Feeding time: $tm = 2.2$ s
- Friction coefficient: $\mu = 0.2$
- Mechanical efficiency: $\eta = 0.9$ (90%)

(1) Speed Diagram

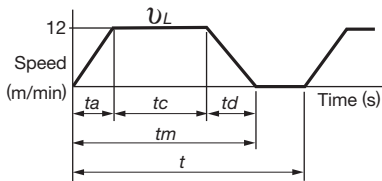

$$t = \frac{60}{n} = \frac{60}{10} = 6.0 \text{ (s)}$$

$$\text{where } ta = td$$

$$\begin{cases} (ta + tc) \times \frac{v_L}{60} = \ell \text{ (m)} \\ (2ta + tc) = tm \end{cases}$$

$$\therefore ta = 0.1 \text{ (s)}$$

$$tc = 2.2 - 2 \times 0.1 = 2.0 \text{ (s)}$$

(2) Rotation Speed

$$\text{• Load axis rotation speed } n_L = \frac{v_L}{P_B} = \frac{12}{0.012} = 1000 \text{ (min}^{-1}\text{)}$$

$$\text{• Motor shaft rotation speed Gear ratio } 1/R = 1/2 \text{ (R=2)}$$

$$\text{Therefore, } n_M = n_L \cdot R = 1000 \times 2 = 2000 \text{ (min}^{-1}\text{)}$$

(3) Load torque

$$T_L = \frac{9.8\mu \cdot m \cdot P_B}{2\pi R \cdot \eta} = \frac{9.8 \times 0.2 \times 750 \times 0.012}{2\pi \times 2 \times 0.9} = 1.56 \text{ (N}\cdot\text{m)}$$

(4) Load Moment of Inertia

$$\text{• Linear motion section } J_{L1} = m \left(\frac{P_B}{2\pi R} \right)^2 = 750 \times \left(\frac{0.012}{2\pi \times 2} \right)^2 = 6.84 \times 10^{-4} \text{ (kg}\cdot\text{m}^2\text{)}$$

$$\text{• Ball screw } J_B = \frac{\pi}{32} \rho \cdot \ell_B \cdot d_B^4 \cdot \frac{1}{R^2} = \frac{\pi}{32} \times 7.87 \times 10^3 \times 2.0 \times (0.1)^4 \cdot \frac{1}{2^2} = 386.32 \times 10^{-4} \text{ (kg}\cdot\text{m}^2\text{)}$$

$$\text{• Coupling } J_G = 12 \times 10^{-4} \text{ (kg}\cdot\text{m}^2\text{)}$$

$$\text{• Load moment of inertia at motor shaft } J_L = J_{L1} + J_B + J_G = (6.84 + 386.32 + 12) \times 10^{-4} = 405.16 \times 10^{-4} \text{ (kg}\cdot\text{m}^2\text{)}$$

(5) Load Moving Power

$$P_O = \frac{2\pi n_M \cdot T_L}{60} = \frac{2\pi \times 2000 \times 1.56}{60} = 327 \text{ (W)}$$

(6) Load Acceleration Power

$$P_a = \left(\frac{2\pi}{60} n_M \right)^2 \frac{J_L}{ta} = \left(\frac{2\pi}{60} \times 2000 \right)^2 \times \frac{405.16 \times 10^{-4}}{0.1} = 17772 \text{ (W)}$$

Servomotor Capacity Selection Examples

(7) Servomotor Provisional Selection

- (a) Selecting Conditions
- $T_L \leq$ Motor rated torque
 - $\frac{(P_O+P_a)}{2} <$ Provisionally selected servomotor rated output $< (P_O+P_a)$
 - $n_M \leq$ Motor rated speed
 - $J_L \leq$ Allowable load moment of inertia

The followings satisfy the conditions.

• Servomotor SGMVV-2BD□B

(b) Specifications of the Provisionally Selected Servomotor

- Rated output : 22000 (W)
- Rated motor speed : 1500 (min⁻¹)
- Rated torque : 140 (N·m)
- Instantaneous peak torque : 350 (N·m)
- Servomotor moment of inertia : 366 × 10⁻⁴ (kg·m²)
- Allowable load moment of inertia : 366 × 10⁻⁴ × 10 = 3660 × 10⁻⁴ (kg·m²)

(8) Verification on the Provisionally Selected Servomotor

• Required acceleration torque: $T_P = \frac{2\pi n_M (J_M + J_L)}{60ta} + T_L = \frac{2\pi \times 2000 \times (366 + 405.16) \times 10^{-4}}{60 \times 0.1} + 1.56$
 $\cong 163 \text{ (N}\cdot\text{m)} <$ Instantaneous peak torque · Satisfactory

• Required deceleration torque: $T_S = \frac{2\pi n_M (J_M + J_L)}{60td} - T_L = \frac{2\pi \times 2000 \times (366 + 405.16) \times 10^{-4}}{60 \times 0.1} - 1.56$
 $\cong 160 \text{ (N}\cdot\text{m)} <$ Instantaneous peak torque · Satisfactory

• Torque effective value: $T_{rms} = \sqrt{\frac{T_P^2 \cdot ta + T_L^2 \cdot tc + T_S^2 \cdot td}{t}} = \sqrt{\frac{(163)^2 \times 0.1 + (1.56)^2 \times 2.0 + (160)^2 \times 0.1}{6}}$
 $\cong 29.5 \text{ (N}\cdot\text{m)} <$ Rated torque · Satisfactory

(9) Result

The provisionally selected servomotor is confirmed to be applicable.
 The torque diagram is shown below.

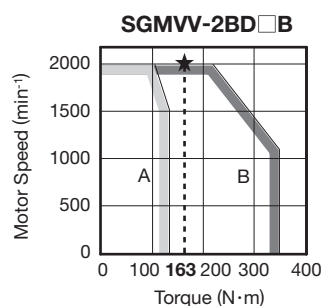
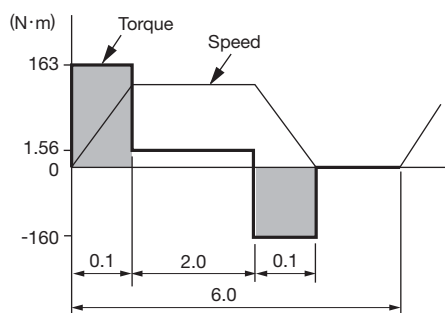

Servomotor Capacity Selection Examples

Use the AC servo drive capacity selection program SigmaSize+ to select servomotor capacity. The program can be downloaded for free from our web site (<http://www.e-mechatronics.com/>).

● Selection Example for Position Control

Mechanical Specifications

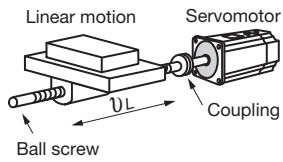

- Load speed: $v_L = 24$ m/min
- Linear motion section mass: $m = 500$ kg
- Ball screw length: $\ell_B = 2.0$ m
- Ball screw diameter: $d_B = 0.1$ m
- Ball screw lead: $P_B = 0.012$ m
- Ball screw material density: $\rho = 7.87 \times 10^3$ kg/m³
- Coupling mass: $m_C = 5.0$ kg
- Coupling outer diameter: $d_C = 0.12$ m
- Positioning times: $n = 10$ times/min
- Positioning distance: $\ell = 0.88$ m
- Positioning time: $t_m = 2.4$ s
- Electrical stop accuracy: $\delta = \pm 0.01$ mm
- Friction coefficient: $\mu = 0.2$
- Mechanical efficiency: $\eta = 0.9$ (90%)

(1) Speed Diagram

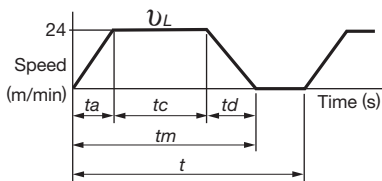

$$t = \frac{60}{n} = \frac{60}{10} = 6.0 \text{ (s)}$$

$$\text{where } t_a = t_d$$

$$\begin{cases} (t_a + t_c) \times \frac{v_L}{60} = \ell \text{ (m)} \\ (2t_a + t_c) = t_m \end{cases}$$

$$\therefore t_a = 0.2 \text{ (s)}$$

$$t_c = 2.4 - 2 \times 0.2 = 2.0 \text{ (s)}$$

(2) Rotation Speed

- Load axis rotation speed $n_L = \frac{v_L}{P_B} = \frac{24}{0.012} = 2000 \text{ (min}^{-1}\text{)}$

- Motor shaft rotation speed with direct coupling: Gear ratio $1/R = 1/1$

$$\text{Therefore, } n_M = n_L \cdot R = 2000 \times 1 = 2000 \text{ (min}^{-1}\text{)}$$

(3) Load Torque

$$T_L = \frac{9.8\mu \cdot m \cdot P_B}{2\pi R \cdot \eta} = \frac{9.8 \times 0.2 \times 500 \times 0.012}{2\pi \times 1 \times 0.9} = 2.08 \text{ (N}\cdot\text{m)}$$

(4) Load Moment of Inertia

- Liner motion section $J_{L1} = m \left(\frac{P_B}{2\pi R} \right)^2 = 500 \times \left(\frac{0.012}{2\pi \times 1} \right)^2 = 18.24 \times 10^{-4} \text{ (kg}\cdot\text{m}^2\text{)}$

- Ball screw $J_B = \frac{\pi}{32} \rho \cdot \ell_B \cdot d_B^4 = \frac{\pi}{32} \times 7.87 \times 10^3 \times 2.0 \times (0.1)^4 = 1545.27 \times 10^{-4} \text{ (kg}\cdot\text{m}^2\text{)}$

- Coupling $J_C = \frac{1}{8} m_C \cdot d_C^2 = \frac{1}{8} \times 5.0 \times (0.12)^2 = 90 \times 10^{-4} \text{ (kg}\cdot\text{m}^2\text{)}$

- Load moment of inertia at the motor shaft $J_L = J_{L1} + J_B + J_C = 1653.51 \times 10^{-4} \text{ (kg}\cdot\text{m}^2\text{)}$

(5) Load Moving Power

$$P_O = \frac{2\pi n_M \cdot T_L}{60} = \frac{2\pi \times 2000 \times 2.08}{60} = 436 \text{ (W)}$$

(6) Load Acceleration Power

$$P_a = \left(\frac{2\pi}{60} n_M \right)^2 \frac{J_L}{t_a} = \left(\frac{2\pi}{60} \times 2000 \right)^2 \times \frac{1653.51 \times 10^{-4}}{0.2} = 36266 \text{ (W)}$$

Servomotor Capacity Selection Examples

(7) Provisionally Servomotor Selection

- (a) Selecting Conditions
- $T_L \leq$ Motor rated torque
 - $\frac{(P_o+P_a)}{2} <$ Provisionally selected servomotor rated output $< (P_o+P_a)$
 - $n_M \leq$ Motor rated speed
 - $J_L \leq$ Allowable load moment of inertia

The followings satisfy the conditions.

- Servomotor SGMVV-3ZA□B

(b) Specifications of Servomotor

- Rated output : 30000 (W)
- Rated motor speed : 1500 (min^{-1})
- Rated torque : 191 ($\text{N}\cdot\text{m}$)
- Instantaneous peak torque : 478 ($\text{N}\cdot\text{m}$)
- Servomotor rotor moment of inertia : 498×10^{-4} ($\text{kg}\cdot\text{m}^2$)
- Allowable load moment of inertia : $498 \times 10^{-4} \times 10 = 4980 \times 10^{-4}$ ($\text{kg}\cdot\text{m}^2$)
- Encoder resolution : 20 bit (1048576P/rev)

(8) Verification on Provisionally Selected Servomotor

· Required acceleration torque: $T_P = \frac{2\pi n_M (J_M + J_L)}{60ta} + T_L = \frac{2\pi \times 2000 \times (498 + 1653.51) \times 10^{-4}}{60 \times 0.2} + 2.08$
 $\cong 227$ ($\text{N}\cdot\text{m}$) < Instantaneous peak torque...Satisfactory

· Required deceleration torque: $T_S = \frac{2\pi n_M (J_M + J_L)}{60td} - T_L = \frac{2\pi \times 2000 \times (498 + 1653.51) \times 10^{-4}}{60 \times 0.2} - 2.08$
 $\cong 223$ ($\text{N}\cdot\text{m}$) < Instantaneous peak torque...Satisfactory

· Torque effective value: $T_{rms} = \sqrt{\frac{T_P^2 \cdot ta + T_L^2 \cdot tc + T_S^2 \cdot td}{t}} = \sqrt{\frac{(452.69)^2 \times 0.2 + (2.08)^2 \times 2.0 + (448.53)^2 \times 0.2}{6.0}}$
 $\cong 58.2$ ($\text{N}\cdot\text{m}$) < Rated torque...Satisfactory

The above confirms that the provisionally selected servomotor is sufficient. The torque diagram is shown below. In the next step, their performance in position control are checked.

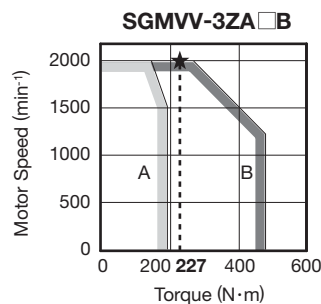
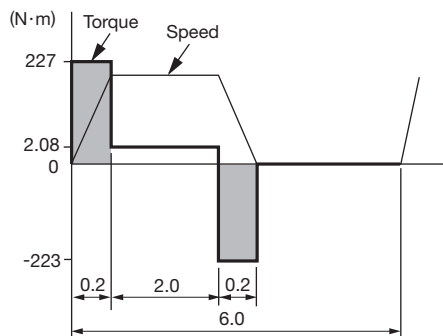

Servomotor Capacity Selection Examples

(9) Position Detection Resolution

Position detection unit uses a $\Delta \ell = 0.01$ mm/pulse.

The number of pulses per motor rotation must be less than resolution of the encoder (P/rev).

$$\text{The number of pulses per revolution (pulse)} = \frac{PB}{\Delta \ell} = \frac{12 \text{ mm}}{0.01 \text{ mm}} = 1200 < \text{encoder resolution [1048576 (P/rev)]}$$

(10) Reference Pulse Frequency

$$v_s = \frac{1000 v_L}{60 \times \Delta \ell} = \frac{1000 \times 12}{60 \times 0.01} = 20,000 \text{ (pps)}$$

Confirm that the maximum input pulse frequency* is greater than the reference pulse frequency.

* : Refer to 1.4.3 Speed/Position/Torque Control in the User's Manual, Design and Maintenance (Manual No.: SIEP S800000 88) for the maximum input pulse frequency.

The above results confirm that the selected servomotor is applicable for the position control.

Regenerative Resistor Capacity Selection

(1) Simple Calculation

The following table summarized the allowable frequencies of regenerative operation for individual servomotors.

Conditions:

- The combination of the SERVOPACK, converter, and regenerative resistor is recommended by Yaskawa. (Refer to page 57.)
- Acceleration and deceleration are repeated for an operation cycle from 0 to the maximum speed to 0 (min^{-1}).

Main Circuit Power Supply Voltage	Servomotor Model	Allowable Frequencies in Regenerative Mode (time/min)				
		2B	3Z	3G	4E	5E
Three-phase 200 V	SGMVV-□□A□B	35	52	44	—	—
	SGMVV-□□A□D	44	48	39	—	—
Three-phase 400 V	SGMVV-□□D□B	53	39	44	36	30
	SGMVV-□□D□D	66	36	39	51	—

Operating Conditions for Allowable Regenerative Frequency Calculation

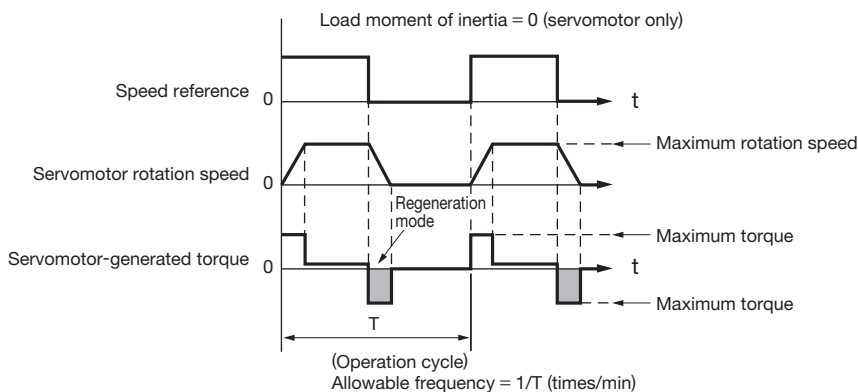

Use the following equation to calculate the allowable frequency for regeneration mode operation

$$\text{Allowable frequency} = \frac{\text{Allowable frequency for Servomotor only}}{(1+n)} \times \left(\frac{\text{Max. rotation speed}}{\text{Rotation speed}} \right)^2 \text{ (time/min)}$$

$$\cdot n = J_L / J_M$$

· J_M : Servomotor rotor moment of inertia ($\text{kg} \cdot \text{m}^2$)

· J_L : Load converted to shaft moment of inertia ($\text{kg} \cdot \text{m}^2$)

Regenerative Resistor Capacity Selection

(2) Calculating the Regenerative Energy

This section shows the procedure for calculating the regenerative resistor capacity when acceleration and deceleration operation is as shown in the following diagram.

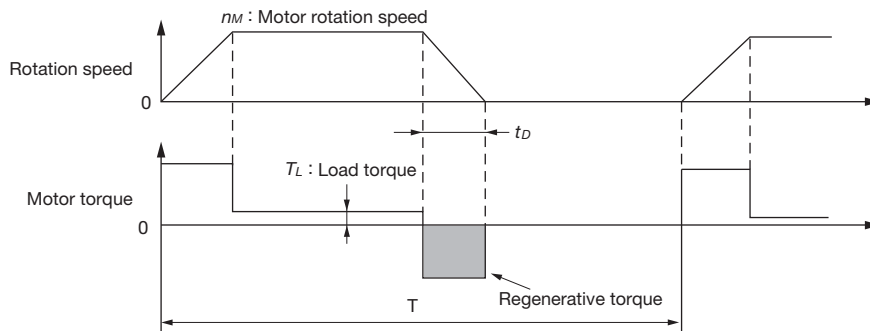

• How to Calculate the Capacity

Step	Item	Symbol	Equation
1	Calculate the rotational energy of the servomotor.	E_s	$E_s = Jn_m^2 / 182$
2	Calculate the energy consumed by load loss during the deceleration period	E_L	$E_L = (\pi/60) n_m T_L t_D$
3	Calculate the energy lost from servomotor winding resistance.	E_M	(Value calculated from (4) <i>Servomotor Winding Resistance Loss</i> diagrams) $\times t_D$
4	Calculate the SERVOPACK energy that can be absorbed.	E_C	Calculate from (3) <i>Absorbable Energy of the SERVOPACK and Converter</i> .
5	Calculate the energy consumed by the regenerative resistor.	E_K	$E_K = E_s - (E_L + E_M + E_C)$
6	Calculate the required regenerative resistor capacity (W).	W_K	$W_K = E_K / (0.2 \times T)$

Notes: 1 The "0.2" in the equation for calculating W_K is the value for when the regenerative resistor's utilized load ratio is 20%.

2 The units for the various symbols are as follows:

E_s to E_K : Energy joules (J)

W_K : Required capacity of regenerative resistor (W)

J : ($=J_M + J_L$) ($\text{kg} \cdot \text{m}^2$)

n_m : Servomotor rotation speed (min^{-1})

T_L : Load torque ($\text{N} \cdot \text{m}$)

t_D : Deceleration stopping time (s)

T : Servomotor repeat operation period (s)

3 If the loss in the load system in step 2 is not known, use an E_L of 0 in the calculation.

If the result of the above calculation shows that the regenerative power that is actually required is larger than the maximum capacity of the regenerative resistor that is a Yaskawa option, you must obtain an external regenerative resistor. If there will be a continuous period of operation in regenerative mode, such as for a vertical axis, add the following items to the above calculation procedure to calculate the required capacity (W) of the regenerative resistor.

- Energy for continuous regeneration mode operation period: E_G (joules)
- Energy consumed by regenerative resistor: $E_K = E_s - (E_L + E_M + E_C) + E_G$
- Required capacity of regenerative resistor: $W_K = E_K / (0.2 \times T)$

Here, $E_G = (2\pi/60) n_{MG} T_G t_G$

- T_G : Servomotor's generated torque in continuous regeneration mode operation period ($\text{N} \cdot \text{m}$)
- n_{MG} : Servomotor rotation speed for same operation period as above (min^{-1})
- t_G : Same operation period as above (s)

Regenerative Resistor Capacity Selection

(3) Absorbable Energy of the SERVOPACK and Converter

The following diagrams show the relationship between the input power supply voltage and the absorbable energy.

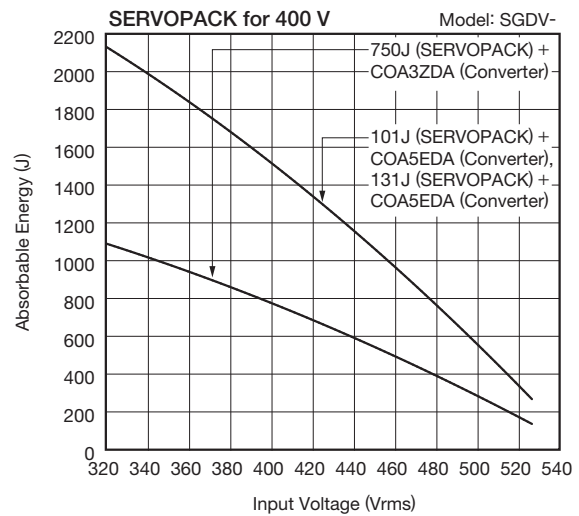
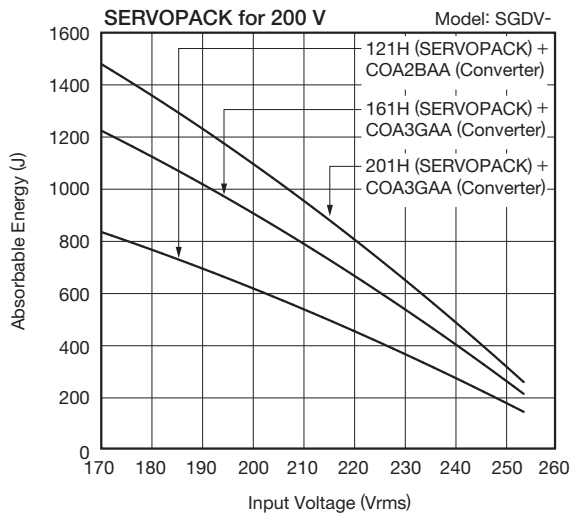

(4) Servomotor Winding Resistance Loss

The following diagrams show the relationship, for each servomotor, between the servomotor's generated torque and the winding resistance loss.

SGMVV Servomotors

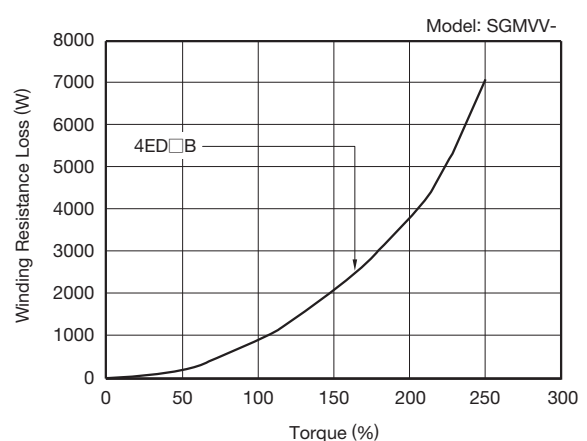
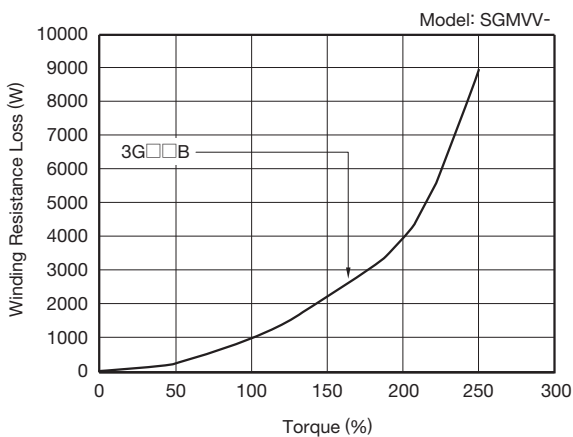
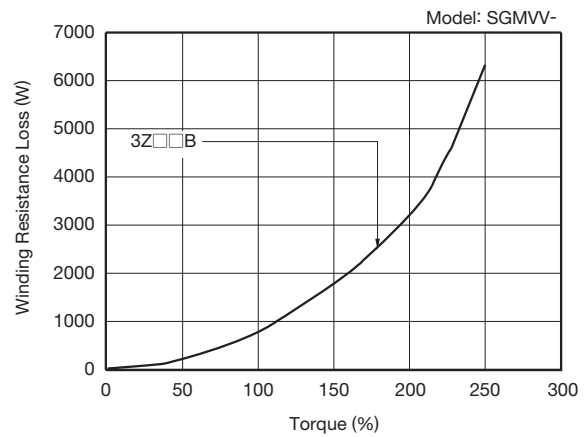
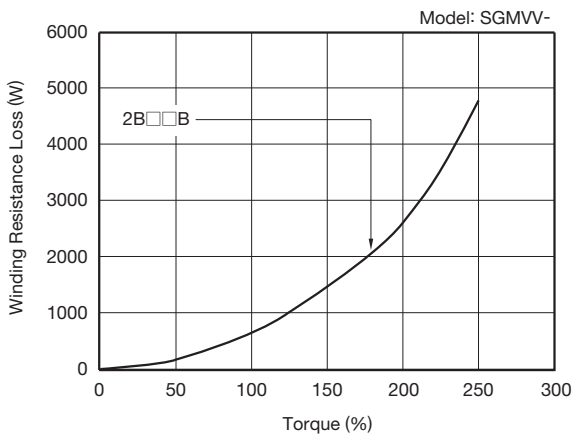

Regenerative Resistor Capacity Selection

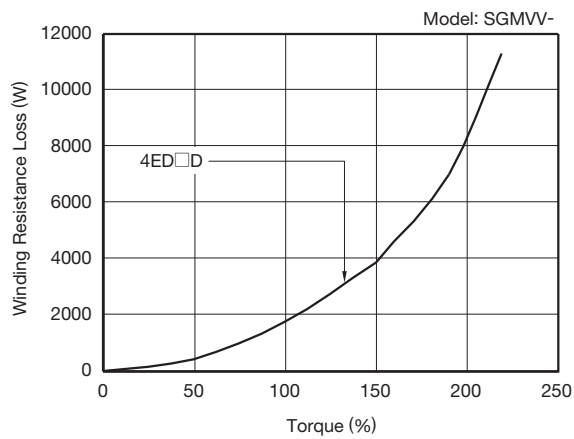
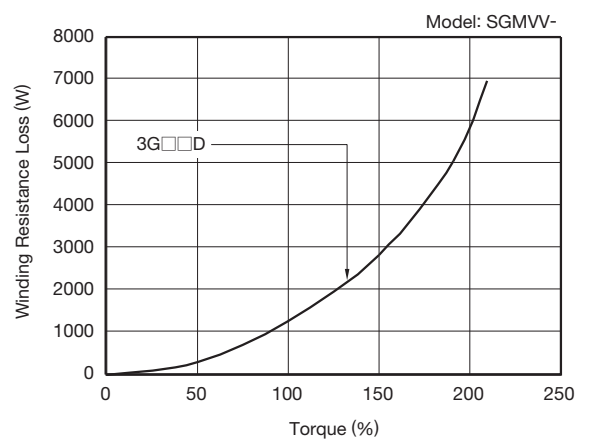
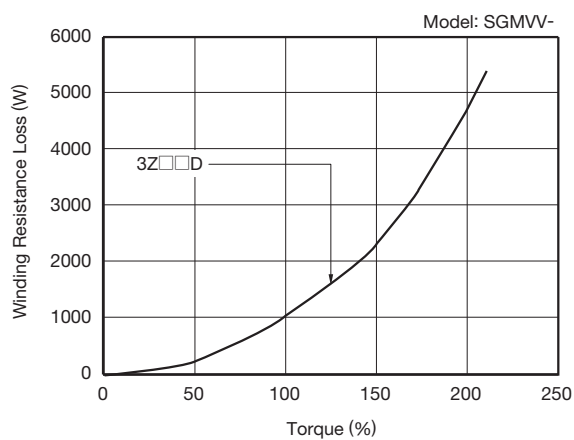
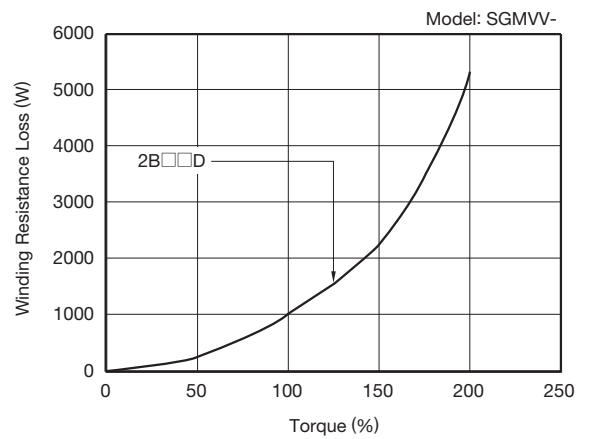
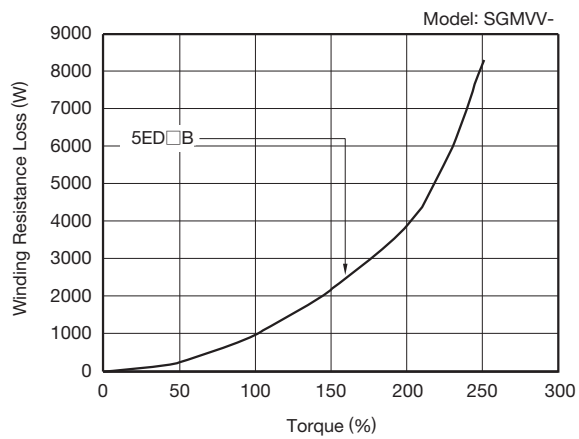

Example of Connection to Machine Controller MP2□□□

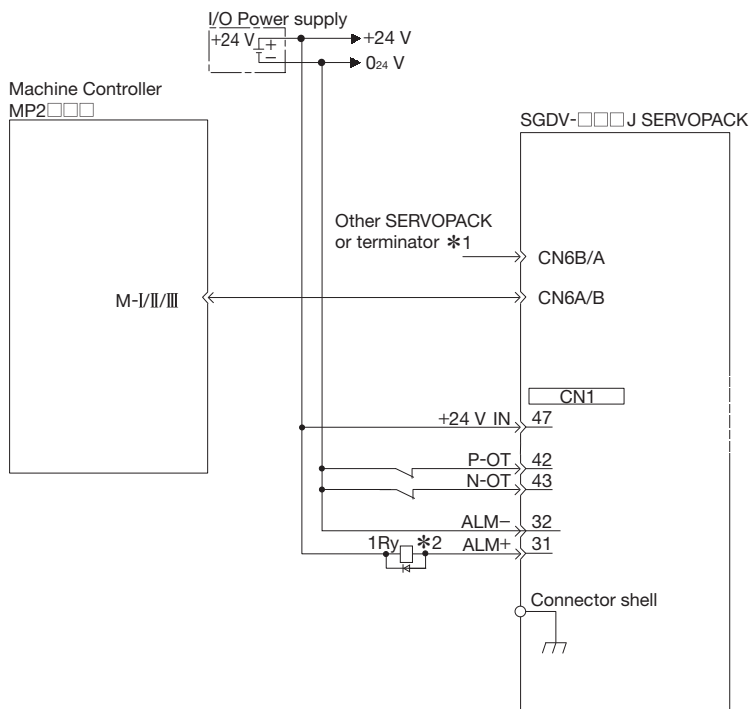

*1 : A terminator is not required when using a MECHATROLINK-III Communications Reference SERVOPACK.

*2 : The ALM signal is output for five seconds or less when the control power supply is turned ON. Take this into consideration when designing the power ON sequence. Design the system so that the ALM signal actuates the 1Ry alarm detection relay to stop the main circuit power supply to the SERVOPACK and converter.

Notes: 1 Only signals applicable to Machine Controller MP2□□□ and Yaskawa's SGD□□□J SERVOPACK are shown in the diagram.

2 Refer to page 49 for information on the main circuit wiring.

3 Incorrect wiring may damage the machine controller, SERVOPACK, or converter. Take particular care to wire correctly.

4 Open the signal lines not to be used.

5 The normally closed (N.C.) input terminals not to be used at the Machine Controller I/O connector section must be shortcircuited at the connector.

Example of Connection to SVA-01 Motion Module for MP2200/MP2300

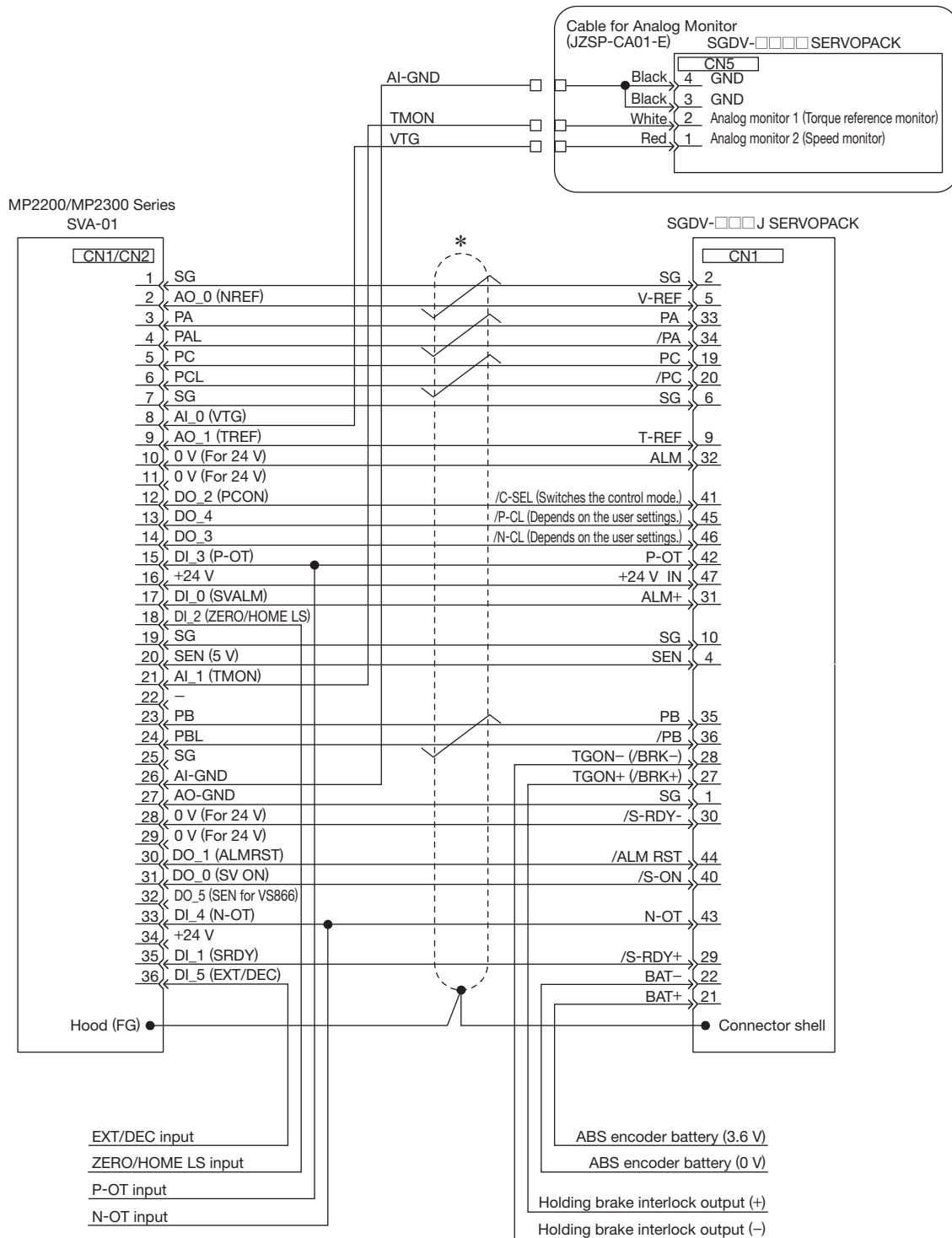



* : represents shielded twisted-pair wires.

- Notes:
- 1 Connection cables (model: JEPMC-W2040-□□) to connect the SERVOPACK to the MP2200/MP2300 are provided by Yaskawa.
 - 2 Only signals applicable to MP2200 / MP2300 Motion Module SVA-01 and Yaskawa's SGDV SERVOPACK are shown in the diagram.
 - 3 Incorrect wiring may damage the machine controller, SERVOPACK, or converter. Take particular care to wire correctly.
 - 4 Open the signal lines not to be used.
 - 5 The above connection diagram shows the connections for only one axis. When using other axes, make connections to the SERVOPACK in the same way.
 - 6 The normally closed (N.C.) input terminals not to be used at the Machine Controller I/O connector section must be shortcircuited at the connector.
 - 7 Make the setting so that the servo can be turned ON/OFF by the /S-ON signal.

Harmonized Standards

North American Safety Standards (UL)

Name (Model)	UL Standards (UL File No.)	Mark	Remarks
SERVOPACK (SGDV-□□□□H, -□□□□J), Converter (SGDV-COA)	UL508C (E147823)		Application pending.
Servomotor (SGMVV)	UL1004 (E165827)		Certified.

European Directives



Name (Model)	European Directives	Harmonized Standards	Remarks
SERVOPACK (SGDV-□□□□H, -□□□□J), Converter (SGDV-COA)	Machinery Directive 2006/42/EC	EN ISO13849-1 : 2008, EN 954-1	Application pending.
	EMC Directive 2004/108/EC	EN 55011 group 1 class A, EN 61000-6-2, EN 61800-3	
	Low Voltage Directive 2006/95/EC	EN 50178, EN 61800-5-1	
Servomotor (SGMVV)	EMC Directive 2004/108/EC	EN 55011 group 1 class A, EN 61000-6-2, EN 61800-3	Application pending.
	Low Voltage Directive 2006/95/EC	EN 60034-1, EN 60034-5/A1	

Safety Standards



Name (Model)	Safety Standards	Standards	Remarks
SERVOPACK (SGDV-□□□□H, -□□□□J), Converter (SGDV-COA)	Safety of Machinery	EN ISO13849-1 : 2008, EN 954-1, IEC 60204-1	Application pending.
	Functional Safety	IEC 61508 series, IEC 62061, IEC 61800-5-2	
	EMC	IEC 61326-3-1	

Safe Performance

Items	Standards	Performance Level
Safety Integrity Level	IEC 61508	SIL2
	IEC 62061	SILCL2
Probability of Dangerous Failure per Hour	IEC 61508 IEC 62061	PFH $\leq 1.7 \times 10^{-9}$ [1/h] (0.17% of SIL2)
Category	EN 954-1	Category 3
Performance Level	EN ISO 13849-1	PL d (Category 3)
Mean Time to Dangerous Failure of Each Channel	EN ISO 13849-1	MTTFd : High
Average Diagnostic Coverage	EN ISO 13849-1	DCave : Low
Stop Category	IEC 60204-1	Stop category 0
Safety Function	IEC 61800-5-2	STO
Proof Test Interval	IEC 61508	10 years

Warranty

(1) Details of Warranty

■ Warranty Period

The warranty period for a product that was purchased (hereinafter called the "delivered product") is one year from the time of delivery to the location specified by the customer or 18 months from the time of shipment from the Yaskawa factory, whichever is sooner.

■ Warranty Scope

Yaskawa shall replace or repair a defective product free of charge if a defect attributable to Yaskawa occurs during the above warranty period. This warranty does not cover defects caused by the delivered product reaching the end of its service life and replacement of parts that require replacement or that have a limited service life.

This warranty does not cover failures that result from any of the following causes.

1. Improper handling, abuse, or use in unsuitable conditions or in environments not described in product catalogs or manuals, or in any separately agreed-upon specifications
2. Causes not attributable to the delivered product itself
3. Modifications or repairs not performed by Yaskawa
4. Use of the delivered product in a manner in which it was not originally intended
5. Causes that were not foreseeable with the scientific and technological understanding at the time of shipment from Yaskawa
6. Events for which Yaskawa is not responsible, such as natural or human-made disasters

(2) Limitations of Liability

1. Yaskawa shall in no event be responsible for any damage or loss of opportunity to the customer that arises due to failure of the delivered product.
2. Yaskawa shall not be responsible for any programs (including parameter settings) or the results of program execution of the programs provided by the user or by a third party for use with programmable Yaskawa products.
3. The information described in product catalogs or manuals is provided for the purpose of the customer purchasing the appropriate product for the intended application. The use thereof does not guarantee that there are no infringements of intellectual property rights or other proprietary rights of Yaskawa or third parties, nor does it construe a license.
4. Yaskawa shall not be responsible for any damage arising from infringements of intellectual property rights or other proprietary rights of third parties as a result of using the information described in catalogs or manuals.

(3) Suitability for Use

1. It is the customer's responsibility to confirm conformity with any standards, codes, or regulations that apply if the Yaskawa product is used in combination with any other products.
2. The customer must confirm that the Yaskawa product is suitable for the systems, machines, and equipment used by the customer.
3. Consult with Yaskawa to determine whether use in the following applications is acceptable. If use in the application is acceptable, use the product with extra allowance in ratings and specifications, and provide safety measures to minimize hazards in the event of failure.
 - Outdoor use, use involving potential chemical contamination or electrical interference, or use in conditions or environments not described in product catalogs or manuals
 - Nuclear energy control systems, combustion systems, railroad systems, aviation systems, vehicle systems, medical equipment, amusement machines, and installations subject to separate industry or government regulations
 - Systems, machines, and equipment that may present a risk to life or property
 - Systems that require a high degree of reliability, such as systems that supply gas, water, or electricity, or systems that operate continuously 24 hours a day
 - Other systems that require a similar high degree of safety
4. Never use the product for an application involving serious risk to life or property without first ensuring that the system is designed to secure the required level of safety with risk warnings and redundancy, and that the Yaskawa product is properly rated and installed.
5. The circuit examples and other application examples described in product catalogs and manuals are for reference. Check the functionality and safety of the actual devices and equipment to be used before using the product.
6. Read and understand all use prohibitions and precautions, and operate the Yaskawa product correctly to prevent accidental harm to third parties.

(4) Specifications Change

The names, specifications, appearance, and accessories of products in product catalogs and manuals may be changed at any time based on improvements and other reasons. The next editions of the revised catalogs or manuals will be published with updated code numbers. Consult with your Yaskawa representative to confirm the actual specifications before purchasing a product.

LARGE-CAPACITY Σ -V SERIES

IRUMA BUSINESS CENTER (SOLUTION CENTER)

480, Kamifujiisawa, Iruma, Saitama, 358-8555, Japan
Phone +81-4-2962-5151 Fax +81-4-2962-6138
<http://www.yaskawa.co.jp>

YASKAWA AMERICA, INC.

2121, Norman Drive South, Waukegan, IL 60085, U.S.A.
Phone +1-800-YASKAWA (927-5292) or +1-847-887-7000 Fax +1-847-887-7310
<http://www.yaskawa.com>

YASKAWA ELÉTRICO DO BRASIL LTDA.

777, Avenida Piraporinha, Diadema, São Paulo, 09950-000, Brasil
Phone +55-11-3585-1100 Fax +55-11-3585-1187
<http://www.yaskawa.com.br>

YASKAWA EUROPE GmbH

Hauptstraße 185, 65760 Eschborn, Germany
Phone +49-6196-569-300 Fax +49-6196-569-398
<http://www.yaskawa.eu.com> E-mail: info@yaskawa.eu.com

YASKAWA ELECTRIC KOREA CORPORATION

35F, Three IFC, 10 Gukjegeumyung-ro, Yeongdeungpo-gu, Seoul, 07326, Korea
Phone +82-2-784-7844 Fax +82-2-784-8495
<http://www.yaskawa.co.kr>

YASKAWA ELECTRIC (SINGAPORE) PTE. LTD.

151, Lorong Chuan, #04-02A, New Tech Park 556741, Singapore
Phone +65-6282-3003 Fax +65-6289-3003
<http://www.yaskawa.com.sg>

YASKAWA ELECTRIC (THAILAND) CO., LTD.

59, 1st-5th Floor, Flourish Building, Soi Ratchadapisek 18, Ratchadapisek Road, Huaykwang, Bangkok 10310, Thailand
Phone: +66-2-017-0099 Fax: +66-2-017-0799
<http://www.yaskawa.co.th>

YASKAWA ELECTRIC (CHINA) CO., LTD.

22F, One Corporate Avenue, No.222, Hubin Road, Shanghai, 200021, China
Phone +86-21-5385-2200 Fax +86-21-5385-3299
<http://www.yaskawa.com.cn>

YASKAWA ELECTRIC (CHINA) CO., LTD. BEIJING OFFICE

Room 1011, Tower W3 Oriental Plaza, No.1, East Chang An Ave.,
Dong Cheng District, Beijing, 100738, China
Phone +86-10-8518-4086 Fax +86-10-8518-4082

YASKAWA ELECTRIC TAIWAN CORPORATION

12F, No. 207, Sec. 3, Beishin Rd., Shindian Dist., New Taipei City 23143, Taiwan
Phone: +886-2-8913-1333 Fax: +886-2-8913-1513 or +886-2-8913-1519
<http://www.yaskawa.com.tw>

YASKAWA**YASKAWA ELECTRIC CORPORATION**

In the event that the end user of this product is to be the military and said product is to be employed in any weapons systems or the manufacture thereof, the export will fall under the relevant regulations as stipulated in the Foreign Exchange and Foreign Trade Regulations. Therefore, be sure to follow all procedures and submit all relevant documentation according to any and all rules, regulations and laws that may apply. Specifications are subject to change without notice for ongoing product modifications and improvements.

© 2012 YASKAWA ELECTRIC CORPORATION

LITERATURE NO. KAEP S800000 86B <1>-2

Published in Japan April 2017
17-3-17